

EVANSVILLE WATER & SEWER UTILITY

WATER AND SEWER MANUAL

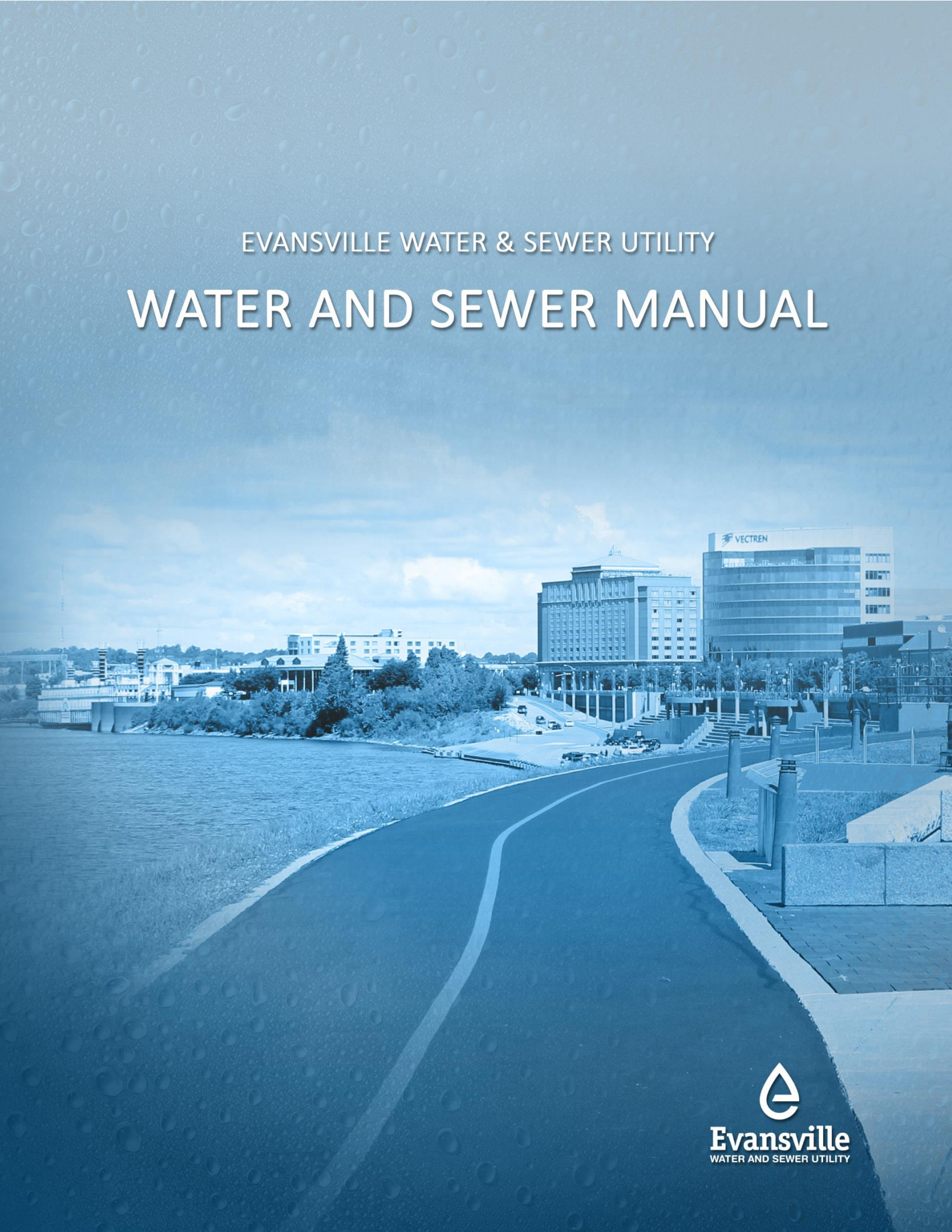

Evansville Water and Sewer Utility

Water and Sewer Manual

Adopted February 28, 2017

Revision	Approved Date

Table of Contents

SECTION 1: INTRODUCTION.....	1-1
1.1 Purpose	1-1
1.2 Description and Use of the Handbook	1-1
1.2.1 Compliance with Other Standards.....	1-1
1.2.2 Conflicting Standards.....	1-2
1.3 Structure of the Handbook	1-2
1.4 Updates to the Handbook.....	1-2
1.5 Enforcement & Penalties	1-2
1.6 Topics Not Included in the Standards	1-3
1.7 Resource Documents for Reference	1-3
1.8 Abbreviations and Definitions.....	1-4
1.8.1 Purpose.....	1-4
1.8.2 Abbreviations.....	1-4
1.8.3 Definitions.....	1-6
1.9 Variances.....	1-12
1.9.1 Purpose.....	1-12
1.9.2 Authority to Waive Requirements.....	1-13
1.9.3 Types of Variances	1-13
1.9.4 Technical Variance Procedures.....	1-13
1.9.4.1 Variance Request Form.	1-13
1.9.4.2 Variance Decision.	1-13
1.9.4.3 Technical Variance Appeals	1-14
1.9.4.3.1 Appeal Filing	1-14
1.9.4.3.2 Appeal Review	1-14
1.9.5 Material Variance Procedures	1-14
1.9.5.1 Variance Request Form	1-14
1.9.5.2 Variance Decision.	1-14
1.9.5.3 Material Variance Appeals	1-14
1.9.5.3.1 Appeal Filing	1-15
1.9.5.3.2 Appeal Review	1-15
SECTION 2: Utility Customers	2-1
2.1 General Rules of Service.....	2-1
2.1.1 Authority and Privileges of Utility Employees –.....	2-1

2.1.2	Quality and Protection of Water.....	2-1
2.1.3	Adequate Service Requirements	2-1
2.1.4	Continuous Service	2-1
2.1.5	Utility Not Liable for Accidents, Breaks, etc.....	2-1
2.1.6	Shut Off Not Cause for Rebate or Refund.....	2-1
2.1.7	Street and Other Valves	2-2
2.1.8	Cisterns	2-2
2.1.9	Secondary or Other Sources of Water Supply	2-2
2.2	Meter Service Application	2-2
2.2.1	General	2-2
2.2.2	¾" and 1" Service	2-3
2.2.3	2" and Larger Service Application	2-4
2.2.4	Split Service Request for 1" and Smaller Services -	2-4
2.2.5	Temporary Metered Service	2-4
2.2.5.1	Deposit & Temporary Fire Hydrant Meter Permit.....	2-4
2.2.5.2	The Temporary Fire Hydrant Meter	2-5
2.2.5.3	Temporary Fire Hydrant Meter readings	2-5
2.2.5.4	Basic Instructions for Use of Temporary Fire Hydrant Meters	2-5
2.2.5.5	When Project is Complete:.....	2-6
2.3	Meter Readings and Billings	2-6
2.3.1	Reading of Meters	2-6
2.3.2	Separate Bills for Each Meter	2-6
2.3.3	Meter Reading Conclusive	2-6
2.3.4	Estimated Readings.....	2-6
2.3.5	Customer Notice	2-7
2.3.6	Payment of Bill	2-7
2.4	DISCONNECTION AND RECONNECTION OF SERVICE.....	2-7
2.4.1	Discontinuance of Service by Utility	2-7
2.4.2	Prohibited Disconnection	2-8
2.4.3	Consumer's Request for Turn Off or Turn On	2-8
2.4.4	Restoration of Service Due to Non-Payment	2-8
2.4.5	Disconnection for Non-Payment of Delinquent Bill.....	2-8
2.4.6	Adjustment or Reduction.....	2-9
2.4.7	Adjustment for Leaks - (Plumber's Affidavit Required)	2-9
2.4.8	Number of Repairs Allowed for Adjustments	2-9
2.4.9	Plumber's Affidavit Form	2-9

2.5	Meters.....	2-9
2.5.1	Meters.....	2-9
2.5.2	Utility to Furnish Meters.....	2-9
2.5.3	Meter Installation Plumbing.....	2-10
2.5.4	Size of Meter Required.....	2-10
2.5.5	Care of Meters.....	2-10
2.5.6	Meter Repairs, Renewals, and Replacements.....	2-10
2.6	Plumbers and Plumbing.....	2-10
2.6.1	License and Permits Must Be Secured.....	2-10
2.6.2	Defective Work.....	2-11
2.6.2.1	Violations of Rules by Plumbers Will Be Cause for Utility to Request License Suspension.....	2-11
2.6.3	Stop Valve and Plumbers.....	2-11
2.6.4	Stop Valve Not to Be Used by Consumer.....	2-11
2.6.5	Care and Use of Service Box, Valve, Valve Box.....	2-11
2.6.6	Shutoff Valve or Stop and Waste Valve.....	2-11
2.6.7	Prohibited Use of Electric Wires for Grounding.....	2-12
2.6.8	Lawn Sprinkling Fixtures.....	2-12
2.6.9	Consumers Having Boiler, Hot Water Heating Systems.....	2-12
2.7	Fire Service.....	2-12
2.7.1	Installation of Service Charges.....	2-12
2.7.2	Size and Number of Services.....	2-12
2.7.3	Contamination of Water Supply.....	2-13
2.7.4	Inspections.....	2-13
2.7.5	The Utility May Install Meter.....	2-13
2.7.6	Guarantees.....	2-13
2.7.7	Public Fire Hydrants.....	2-13
2.7.8	Obstruction of and Damage to Fire Hydrants.....	2-13
2.7.9	Temporary Permits Issued.....	2-13
2.7.10	Temporary Permit Form.....	2-14
2.8	Consumer and Utility Responsibilities.....	2-14
2.8.1	Consumers Must not Permit Others to Use Water.....	2-14
2.8.2	Change in Ownership.....	2-14
2.8.3	Size of service.....	2-14
2.8.4	Consumer to Make All Private Connections.....	2-14
2.8.5	Repairs, Renewals, Replacements, and Relocations.....	2-14
2.8.6	Stop Valve Not to Be Used By Consumer.....	2-15

2.8.7	Retired Service Request	2-15
2.8.8	Sanitary Sewer Responsibility	2-15
2.8.9	Sewer Later Connection Conditions	2-15
2.9	Complaints	2-15
2.9.1	Complaints	2-15
2.9.2	Rule as Part of Contract	2-16
SECTION 3: Developers		3-1
3.1	Introduction	3-1
3.1.1	Purpose	3-1
3.1.2	Applicability	3-1
3.1.3	Ownership	3-1
3.1.4	Organization of Water and Sewer Main Extension Procedures	3-2
3.1.5	Compliance with Other Standards	3-2
3.2	General	3-3
3.2.1	Engineering Expectations	3-3
3.2.2	Dependency on EWSU for Operation During Project Construction	3-3
3.2.3	Types of Applications	3-3
3.2.4	Simple Inquiry	3-4
3.2.5	Early Coordination	3-4
3.2.5.1	Submittal Procedures	3-4
3.2.5.2	Service Connections	3-5
3.2.5.3	Limitations and/or Disclaimers Regarding Early Coordination Process	3-5
3.2.6	Methods of Generating Formal Review by EWSU	3-6
3.2.6.1	Subdivision Submittals	3-6
3.2.6.2	Commercial or Industrial Site Submittals	3-6
3.2.6.3	Preliminary Applications	3-6
3.2.7	Utility Participation	3-7
3.2.7.1	Sanitary Sewer Main Extension Participation	3-7
3.2.7.2	Water Main Extensions	3-7
3.2.8	Utility Coordination	3-8
3.2.9	Professional Certification	3-8
3.2.10	Opinions of Probable Project Cost for Letters of Credit	3-9
3.2.11	Confidentiality	3-9
3.2.12	Transferability	3-9
3.2.12.1	Changes in project Ownership	3-9

3.2.12.2	Changes in Project Engineer	3-10
3.2.12.2.1	Record Drawings.....	3-10
3.3	Application, Approval, Construction, Close-Out Procedures	3-10
3.3.1	Sanitary Sewer Main Extension	3-10
3.3.1.1	General	3-10
3.3.1.2	Reliance Upon GIS Mapping.....	3-10
3.3.1.3	Application	3-10
3.3.1.4	Review Process.....	3-12
3.3.1.5	Utility Board Approval.....	3-12
3.3.1.6	Construction	3-12
3.3.1.7	Testing.....	3-13
3.3.1.8	Acceptance Procedure	3-13
3.3.1.9	Warranty Period	3-14
3.3.2	Water Main Extension	3-14
3.3.2.1	General	3-14
3.3.2.2	Reliance Upon GIS Mapping.....	3-15
3.3.2.3	Application	3-15
3.3.2.4	Review Process.....	3-16
3.3.2.5	Plan Approval	3-17
3.3.2.6	Construction	3-17
3.3.2.7	Testing.....	3-17
3.3.2.8	Acceptance Procedure	3-18
3.3.2.9	Warranty Period	3-18
3.3.3	Large Water Services (2 Inch and Larger) and All Commercial Services	3-19
3.3.3.1	General	3-19
3.3.3.2	Application	3-19
3.3.3.3	Review Process.....	3-20
3.3.3.4	Plan Approval	3-20
3.3.3.5	Construction	3-21
3.3.3.6	Testing.....	3-21
3.3.3.7	Acceptance Procedure	3-21
3.3.3.8	Warranty Period	3-22
SECTION 4: Engineers		4-1
4.1	Survey.....	4-1

4.1.1	Purpose	4-1
4.1.2	General	4-1
4.1.3	Survey Notification	4-1
4.1.4	Horizontal and Vertical Control	4-2
4.1.4.1	U.S. Survey Foot	4-2
4.1.4.2	Guidelines.....	4-2
4.1.4.3	Datum.....	4-2
4.1.4.4	Location Witness	4-2
4.1.4.5	Degree of Accuracy.....	4-3
4.1.4.6	Control Points.....	4-3
4.1.5	Survey Information and Data Collection.....	4-5
4.1.5.1	Area to be Surveyed	4-5
4.1.5.2	Physical Features to be Identified	4-5
4.1.5.3	Survey Information Needed for Trees	4-5
4.1.5.4	Field Profile Requirements	4-6
4.1.5.5	Cross sections	4-6
4.1.5.6	Subsurface and Overhead Utilities	4-6
4.1.5.7	Summary of Topographic Survey Elements.....	4-7
4.1.6	Special Surveys and Topographical Information.....	4-8
4.1.6.1	Property Surveys	4-8
4.1.6.2	Railroad and Highway Surveys	4-9
4.1.6.2.1	Railroads	4-9
4.1.6.2.2	Highways (INDOT Controlled Roadways).....	4-9
4.1.7	Construction Staking.....	4-10
4.1.7.1	Construction Staking	4-10
4.2	Easements	4-10
4.2.1	Purpose	4-10
4.2.2	Existing Easements	4-10
4.2.3	Types of Interest in Real Property for EWSU	4-11
4.2.3.1	Fee Simple Title	4-11
4.2.3.2	Sanitary Sewer Perpetual Easements and Potable Water Perpetual Easements.....	4-11
4.2.3.3	Temporary Construction Easement.....	4-11
4.2.4	Easement Widths	4-12
4.2.5	Construction Plan Requirements	4-12
4.2.6	Easement Description Criteria	4-12

4.2.6.1	General Description Elements	4-12
4.2.6.2	When Multiple Descriptions are Required	4-13
4.2.6.3	Aliquot Descriptions	4-13
4.2.6.4	Metes and Bounds Descriptions.....	4-14
4.2.7	Easement Plat Criteria	4-14
4.2.7.1	General Requirements	4-14
4.2.7.2	Release of Easement	4-15
4.2.8	Easements on Railroad Rights-of-Way.....	4-15
4.2.9	Easement Encroachments	4-15
4.2.9.1	Easement Encroachment Agreements	4-15
4.2.10	Property Acquisition Summary Sheet	4-15
4.2.10.1	Parcel Numbers.....	4-15
4.2.10.2	Owner’s Name	4-16
4.2.10.3	Property Address	4-16
4.2.10.4	Sheet Number	4-16
4.2.10.5	Source of Title	4-16
4.2.10.6	Total Area of Tract	4-16
4.2.10.7	Area of Easements	4-16
4.2.10.8	Remarks	4-16
4.2.10.9	Easement Document Number.....	4-16
4.3	Final Record Drawings.....	4-17
4.3.1	Purpose	4-17
4.3.2	Documentation and Approval Process	4-17
4.3.3	Drawing Information.....	4-17
4.3.4	Drawing Requirements	4-17
4.3.4.1	Survey Datum:	4-17
4.3.4.2	Survey Accuracy:	4-18
4.3.4.3	Record Drawings.....	4-18
4.3.4.3.1	Alignment	4-18
4.3.4.3.2	Elevation	4-18
4.3.4.3.3	Pipe Characteristics	4-18
4.3.4.3.4	Materials.....	4-19
4.3.4.3.5	General Record Drawing Requirements	4-19
4.3.4.3.6	Data Tables for GIS	4-19
4.4	Sanitary Sewer Design.....	4-20

4.4.1	Introduction	4-20
4.4.1.1	Purpose.....	4-20
4.4.1.2	Applicability	4-20
4.4.1.3	Variances	4-20
4.4.1.4	Ownership	4-21
4.4.1.5	Organization of Sanitary Standards.....	4-21
4.4.1.6	Compliance with other Standards	4-21
4.4.2	Sanitary Sewer Mains	4-22
4.4.2.1	Purpose.....	4-22
4.4.2.2	General Improvement Location Criteria.....	4-23
4.4.2.3	Horizontal Alignment Criteria.....	4-23
4.4.2.3.1	Placement in Existing Right-of-Way.....	4-24
4.4.2.3.2	Placement Outside of Existing Right-of-Way	4-24
4.4.2.3.3	Rear Lot Alignment	4-24
4.4.2.3.4	Minimum Distance from Structures	4-25
4.4.2.3.5	Location in Relation to Streams and Waterways.....	4-25
4.4.2.3.6	Location in Relation to Public Water Supply Wells.....	4-25
4.4.2.4	Vertical Alignment Criteria	4-25
4.4.2.4.1	Sanitary Sewer Depths.....	4-25
4.4.2.4.2	Minimum Vertical Separation from Water Mains (Crossings).....	4-26
4.4.2.4.3	Stream and Waterway Crossings.....	4-26
4.4.2.4.4	Aerial Crossings.....	4-27
4.4.2.5	Cleanouts.....	4-27
4.4.2.6	Manholes.....	4-27
4.4.2.6.1	General Notes	4-28
4.4.2.6.2	Manhole Location	4-28
4.4.2.6.3	Manhole Materials	4-29
4.4.2.6.4	Manhole Castings	4-30
4.4.2.6.5	Flow Channel	4-31
4.4.2.6.6	Buoyancy	4-31
4.4.2.6.7	Pipe Connections	4-31
4.4.2.7	Pipe Material	4-32
4.4.2.7.1	Smooth wall Polyvinyl Chloride (PVC).....	4-32
4.4.2.7.2	Polyvinyl Chloride C-900	4-33

4.4.2.7.3	Polyvinyl Chloride C-905	4-33
4.4.2.7.4	Vitrified Clay Pipe.....	4-33
4.4.2.8	Pipe Bedding.....	4-33
4.4.2.8.1	Terms	4-33
4.4.2.8.2	Rigid Pipe Embedment	4-34
4.4.2.8.3	Non-Rigid Pipe Embedment.....	4-35
4.4.2.9	Pipe Backfilling	4-35
4.4.2.9.1	Terms:	4-36
4.4.2.10	Pipe Installation	4-37
4.4.2.10.1	Sanitary Sewer Clearances.....	4-37
4.4.2.10.2	Depth Restrictions	4-37
4.4.2.11	Design Flow	4-38
4.4.2.12	Hydraulic Design Criteria.....	4-39
4.4.2.12.1	Changes in Sanitary Sewer Pipe Sizes	4-40
4.4.2.12.2	Minimization of Solids Deposition	4-40
4.4.2.12.3	Hydraulic Computations	4-41
4.4.2.13	Downstream Capacity Evaluation	4-41
4.4.2.13.1	Temporary Flow Monitoring (if necessary).....	4-41
4.4.2.13.2	Hydraulic Modeling.....	4-42
4.4.2.14	Pipe Criteria.....	4-42
4.4.2.14.1	Sewer Pipe Design	4-42
4.4.2.14.2	Floatation.....	4-43
4.4.2.14.3	Anchors.....	4-43
4.4.2.14.4	Concrete Encasement.....	4-43
4.4.2.14.5	Railroad Crossings.....	4-43
4.4.2.14.6	Highway Crossings	4-44
4.4.2.14.7	Jack and Boring – Casing Pipe.....	4-45
4.4.2.15	Siphons.....	4-45
4.4.2.16	Connection of New Sewers to Existing Sewers	4-46
4.4.2.17	Wye and Lateral Installation	4-46
4.4.3	Sanitary Sewer Laterals.....	4-46
4.4.3.1	Purpose.....	4-46
4.4.3.2	Prohibited Connections	4-47
4.4.3.3	Buildings Serviced.....	4-47

4.4.3.4	Gravity Sewer Service	4-47
4.4.3.5	Non-Gravity Service	4-48
4.4.3.6	Sanitary Sewer Lateral Location, Elevation, and Spacing	4-48
4.4.3.6.1	Sanitary Sewer Lateral Location	4-48
4.4.3.6.2	Sanitary Sewer Lateral Elevation	4-48
4.4.3.6.3	Sanitary Sewer Lateral Spacing	4-48
4.4.3.7	Sanitary Sewer Laterals Crossing Drainage Ways	4-48
4.4.3.8	Hydraulic Design	4-49
4.4.3.9	Sanitary Sewer Lateral Pipe	4-49
4.4.3.10	Sanitary Sewer Lateral Appurtenances	4-49
4.4.3.10.1	Cleanouts	4-49
4.4.3.10.2	Fats, Oils, and Grease (FOG) Interceptors and/or Separators	4-50
4.4.3.10.3	Requirements for Grease Interceptors:	4-50
4.4.3.10.4	Requirements for Sand/Oil Separators:	4-51
4.4.3.10.5	Control Manholes	4-51
4.4.3.11	Lateral Connection to Main Line Sewer	4-52
4.4.3.12	Private Pressure Sewer Connection to Main Line Sewer	4-52
4.4.3.13	Future Connections to New Mains	4-52
4.4.3.14	Proper Abandonment of Sewer Lateral	4-53
4.4.4	Sanitary Sewer Lift Stations	4-53
4.4.4.1	Introduction	4-53
4.4.4.2	Lift Station Location Criteria	4-54
4.4.4.2.1	Roadway, Parking, and Access Requirements	4-54
4.4.4.2.2	Protection against Flooding	4-54
4.4.4.2.3	Site Requirements	4-54
4.4.4.2.4	Mechanical Building	4-54
4.4.4.3	Lift station Type	4-55
4.4.4.4	Lift Station Hydraulic Design	4-55
4.4.4.4.1	Total Dynamic Head Calculations	4-55
4.4.4.4.2	Pump Selection	4-56
4.4.4.4.3	Net Positive Suction Head	4-57
4.4.4.5	Pumps, Motors and Seals	4-57
4.4.4.6	Guide Rails	4-58
4.4.4.7	Wet Well Design	4-58

4.4.4.7.1	Wet Well Materials	4-58
4.4.4.7.2	Wet Well Sizing	4-59
4.4.4.7.3	Buoyancy	4-59
4.4.4.7.4	Connection to Wet Well	4-59
4.4.4.7.5	Hydrogen Sulfide Protection.....	4-59
4.4.4.8	Operating Set Points.....	4-59
4.4.4.9	Valve Vault, Air Release/Vacuum Valve, and Meter Vault Structures	4-60
4.4.4.9.1	Valve Vault	4-60
4.4.4.9.2	Combination Air Release/Vacuum Valve Structure	4-60
4.4.4.9.3	Meter Vault and Sample Point Structure.....	4-61
4.4.4.10	Valves, Discharge Piping, Meter, and By-Pass Connection	4-61
4.4.4.10.1	Discharge Piping	4-61
4.4.4.10.2	Check Valves	4-61
4.4.4.10.3	Plug Valves	4-61
4.4.4.10.4	By-Pass Connection	4-61
4.4.4.10.5	Metering Equipment.....	4-62
4.4.4.10.6	Miscellaneous	4-62
4.4.4.11	Sealing Flange	4-62
4.4.4.12	Ventilation of Structures	4-62
4.4.4.13	Electrical.....	4-62
4.4.4.14	Emergency Operation	4-64
4.4.4.15	Force Main Design Criteria.....	4-64
4.4.4.15.1	General	4-64
4.4.4.15.2	Materials.....	4-65
4.4.4.15.3	Valves and Fittings	4-65
4.4.5	Low Pressure Sanitary Sewer Systems.....	4-65
4.4.5.1	Introduction.....	4-65
4.4.5.2	Low Pressure Sewer System Service Area	4-66
4.4.5.3	Responsibility	4-66
4.4.5.4	System Design and Layout.....	4-66
4.4.5.4.1	Pipe Size	4-66
4.4.5.4.2	Overall System Design/Layout.....	4-66
4.4.5.4.3	Cleanouts	4-66
4.4.5.4.4	Air Release Valves.....	4-66

4.4.5.4.5	Sanitary Sewer Lateral Connection.....	4-67
4.4.5.5	Maximum Connections to Grinder Lift stations	4-67
4.4.5.6	Grinder Pump Type	4-67
4.4.5.7	Grinder Lift station Equipment.....	4-67
4.4.5.7.1	Grinder Lift station.....	4-67
4.4.5.7.2	Manufacturer.....	4-67
4.4.5.7.3	Pumps	4-68
4.4.5.7.4	Electrical Motor and Level Controls.....	4-68
4.4.5.7.5	Control Panels.....	4-68
4.4.5.7.6	Generator Hook Up.....	4-68
4.5	Water Main Design	4-68
4.5.1	Purpose.....	4-68
4.5.1.1	Basic Elements of Design.....	4-68
4.5.1.2	Covered in this Chapter.....	4-69
4.5.2	General Improvement Location Criteria	4-69
4.5.3	Horizontal Alignment Criteria	4-70
4.5.3.1	Placement in Existing Right-of-Way (in cases where easement is not feasible)	4-70
4.5.3.2	Placement Outside of Existing Right-of-Way.....	4-70
4.5.3.3	Minimum Horizontal Separations from Sewers (327 IAC 8-3.2-9)	4-70
4.5.3.4	Minimum Distance from Buildings	4-71
4.5.3.5	Minimum Distance from Storage Tanks	4-71
4.5.3.6	Minimum Distance from Liquid Petroleum and High Pressure Piping	4-71
4.5.3.7	Minimum Distances from Utilities Other than Sewers.....	4-71
4.5.3.8	Minimum Distance from Potential Contamination Sources.....	4-72
4.5.3.9	Location in Relation to Streams and Waterways	4-72
4.5.3.10	Allowable Horizontal Pipe Deflection	4-73
4.5.3.11	Angle of Intersection.....	4-73
4.5.4	Vertical Alignment Criteria	4-73
4.5.4.1	Minimum Depth of Cover.....	4-73
4.5.4.2	Minimum Vertical Separation from Sewers	4-73
4.5.4.3	Air Release Structures	4-74
4.5.4.4	Stream and Waterway Crossings.....	4-74
4.5.4.5	Allowable Vertical Pipe Deflection	4-74
4.5.5	Pipe Bedding and Backfill.....	4-74
4.5.6	Design Demand.....	4-75

4.5.6.1	Method 1 - General Average Daily Demand for Residential Connections	4-75
4.5.6.2	Method 2 – From MRO Data for Residential Connections	4-75
4.5.6.3	Method 3 – For other than Residential Connections	4-76
4.5.6.4	Fire Flow	4-78
4.5.6.4.1	Residential	4-78
4.5.6.4.2	Commercial and Industrial.....	4-78
4.5.7	Hydraulic Design Criteria	4-78
4.5.7.1	Pressure and Flow Rate	4-78
4.5.7.2	Velocity.....	4-79
4.5.7.3	Data Requirements.....	4-79
4.5.7.3.1	Topographic.....	4-79
4.5.7.3.2	Soils Testing (Survey)	4-79
4.5.7.3.3	Flow Testing.....	4-80
4.5.7.4	Hydraulic Calculations	4-80
4.5.7.5	General Hydraulic Calculation Requirements.....	4-80
4.5.7.5.1	Roughness Coefficients.....	4-80
4.5.7.5.2	Minor Losses	4-80
4.5.7.5.3	Friction Losses.....	4-81
4.5.7.5.4	Changes Due to Elevation	4-81
4.5.7.6	Translation of Flow Test Results.....	4-81
4.5.7.7	Existing Water Main Conditions	4-81
4.5.7.8	Most Remote Tests.....	4-82
4.5.7.9	Water Main Over-sizing.....	4-82
4.5.8	Water Main Pipe Requirements	4-82
4.5.9	Joint Restraint	4-82
4.5.9.1	Restrained Joint Location Requirements.....	4-82
4.5.9.2	Restrained Joint Calculations	4-83
4.5.9.3	Restrained Joint Materials.....	4-83
4.5.10	Casing Pipe.....	4-83
4.5.10.1	Casing Pipe Requirements	4-83
4.5.10.2	Casing End Seals.....	4-84
4.5.10.3	Casing Spacers.....	4-84
4.5.11	Infrastructure Crossings.....	4-84
4.5.11.1	Railroad Crossings	4-84
4.5.11.1.1	Criteria	4-84

4.5.11.2	Railroad Crossing Drawings.....	4-85
4.5.11.3	Highway Crossings.....	4-85
4.5.11.3.1	Criteria	4-85
4.5.12	Building Services	4-86
4.5.12.1	Introduction	4-86
4.5.12.1.1	Plumbing Codes	4-86
4.5.12.1.2	Covered in this Chapter	4-86
4.5.12.2	Service Lines General	4-86
4.5.12.2.1	Sizing Water Service Lines	4-86
4.5.12.2.2	Service Requirements	4-87
4.5.12.3	Services 2" and Less	4-87
4.5.12.3.1	Corporation Stops.....	4-87
4.5.12.3.2	Curb Stops.....	4-87
4.5.12.3.3	Metering	4-87
4.5.12.4	Services Greater Than 2"	4-88
4.5.12.4.1	Connection.....	4-88
4.5.12.4.2	Metering	4-88
4.5.12.5	Service Meters	4-88
4.5.12.5.1	Meter Requirements	4-88
4.5.12.5.2	Bypass Requirements	4-88
4.5.12.6	Connections Using an Existing Building Service	4-89
4.5.13	Appurtenances.....	4-89
4.5.13.1	Introduction	4-89
4.5.13.2	Valves	4-89
4.5.13.2.1	Valve Location.....	4-89
4.5.13.2.2	Valve Requirements.....	4-90
4.5.13.3	Fire Hydrants.....	4-90
4.5.13.3.1	Hydrant Requirements	4-90
4.5.13.3.2	Drainage.....	4-90
4.5.13.3.3	Location	4-90
4.5.13.3.4	Protection	4-91
4.5.13.4	End Points of Water Mains	4-91
4.5.13.5	Fittings.....	4-91
4.5.13.5.1	Water Main Crossing Connection	4-91

4.5.13.5.2	Water Main Deflection	4-91
4.5.13.6	Air Relief Valves	4-92
4.5.13.7	Blow-Off Assemblies	4-92
4.5.13.8	Temporary Test Risers.....	4-92
4.5.13.9	Tracing Wire	4-92
4.5.13.10	Polyethylene Wrap (Polywrap)	4-92
4.5.14	Backflow Prevention	4-92
4.5.14.1	Introduction	4-92
4.5.14.1.1	References	4-93
4.5.14.1.2	Covered in this Chapter	4-93
4.5.14.2	Submittals	4-93
4.5.14.3	Backflow Prevention Requirements.....	4-93
4.5.14.3.1	Existing Facilities	4-94
4.5.14.3.2	Existing Facilities with a Cross Connection	4-95
4.5.14.4	Backflow Prevention Exemption	4-95
4.5.14.5	Types of Backflow Prevention	4-95
4.5.14.5.1	Air Gap (AG)	4-95
4.5.14.5.2	Atmospheric Vacuum Breaker (AVB)	4-96
4.5.14.5.3	Pressure Vacuum Breaker (PVB).....	4-96
4.5.14.5.4	Double Check Valves (DC).....	4-97
4.5.14.5.5	Reduced Pressure Principle Backflow Preventer (RP)	4-97
4.5.14.6	Appropriate Use of Backflow Prevention Devices	4-98
4.5.14.7	Installation Requirements.....	4-98
4.5.14.7.1	Location	4-98
4.5.14.7.2	Multiple Services	4-99
4.5.14.8	Inspection Requirements	4-99
4.5.14.9	Inspection Reporting.....	4-99
4.5.14.10	Disconnection/Removal/Bypass	4-99
4.5.15	Fire Services	4-99
4.5.15.1	Introduction	4-99
4.5.15.1.1	Codes	4-100
4.5.15.1.2	Covered in this Chapter	4-100
4.5.15.2	Submittals and Approvals	4-100
4.5.15.3	General Requirements	4-100

4.5.15.4	Service Line Separation	4-100
4.5.15.5	Appurtenances	4-100
4.5.15.5.1	General	4-100
4.5.15.5.2	Backflow Prevention Device	4-101
4.5.15.5.3	Fire Booster Pump	4-101
4.5.15.5.4	On-Site Water Storage.....	4-101
4.5.15.6	Installation and Inspection.....	4-101
4.5.15.6.1	Installation	4-101
4.5.15.6.2	Inspection	4-101
SECTION 5: Contractors		5-1
5.1	Contractor Approval Policy	5-1
5.1.1	Purpose	5-1
5.1.2	Applicability	5-1
5.1.3	Existing Approved Contractors	5-1
5.1.4	New Contractor Application for Approval	5-1
5.1.4.1	Requirements for Pre-Qualification	5-1
5.1.5	Compliance with Approved Drawings and Standards.....	5-2
5.1.6	Performance Criteria and Evaluation.....	5-2
5.1.6.1	Contractor Underperformance	5-2
5.1.6.2	Notice of Violation and Appeal.....	5-3
5.1.6.3	Penalties for Violations.....	5-3
5.2	Field Adjustment Notification Hierarchy.....	5-19
5.3	Technical Specifications - Sanitary Sewer	5-19
5.3.1	Embedment and Backfill	5-19
5.3.1.1	General	5-19
5.3.1.2	Definitions and General Considerations.....	5-19
5.3.1.3	Products.....	5-19
5.3.1.3.1	Bedding and Backfill of Trench Excavations for Pipes and Conduits	5-19
5.3.1.3.2	Structural Backfill.....	5-19
5.3.1.4	Execution	5-22
5.3.1.4.1	Rigid Pipe Embedment and Compaction	5-22
5.3.1.4.2	Non-Rigid Pipe Embedment and Compaction	5-22
5.3.1.4.3	Final Trench Backfilling	5-23
5.3.1.4.4	Temporary Surfaces Subject to Traffic.....	5-23

5.3.1.4.5	Maintaining Trench Surfaces	5-23
5.3.1.4.6	Backfill Around Structures	5-24
5.3.2	Excavations	5-25
5.3.2.1	General	5-25
5.3.2.2	Execution	5-25
5.3.2.2.1	Clearing	5-25
5.3.2.2.2	Protection of Existing Improvements Required to Remain in Place	5-26
5.3.2.2.3	Pavement Removal	5-26
5.3.2.2.4	Maintenance of Roadway Access	5-26
5.3.2.2.5	Utility Protection	5-26
5.3.2.2.6	Deviations from Line and Grade Due to Unforeseen Underground Issues	5-27
5.3.2.2.7	Construction in Easements	5-27
5.3.2.2.8	Maintenance of Existing Drainage Flow	5-27
5.3.2.2.9	Trench Dimensions	5-27
5.3.2.2.10	Earth Excavation	5-27
5.3.2.2.11	Boring and Jacking	5-28
5.3.2.2.12	Removal of Water	5-28
5.3.3	Gravity Sanitary Sewer Pipe	5-28
5.3.3.1	General	5-28
5.3.3.1.1	Description	5-28
5.3.3.1.2	Quality Assurance	5-28
5.3.3.1.3	Submittals	5-29
5.3.3.2	Products	5-29
5.3.3.2.1	Polyvinyl Chloride (PVC) Pipe, SDR 26	5-29
5.3.3.2.2	Polyvinyl Chloride (PVC) Pipe, C-900/C-905	5-30
5.3.3.2.3	Vitrified Clay Pipe	5-32
5.3.3.3	Execution	5-32
5.3.3.3.1	General	5-32
5.3.3.3.2	Rigid Pipe Installation (Vitrified Clay Pipe)	5-33
5.3.3.3.3	Flexible Pipe Installation (PVC C900 or PVC SDR 26)	5-35
5.3.3.3.4	Testing Gravity Sanitary Sewers General	5-35
5.3.3.3.5	Low Pressure Air Test (All Approved Gravity Sanitary Sewer Pipe Materials)	5-35
5.3.3.3.6	Deflection Test for Flexible Pipe	5-38
5.3.4	Standard Manholes	5-43

5.3.4.1	General	5-43
5.3.4.1.1	Description	5-43
5.3.4.1.2	Related Specifications	5-43
5.3.4.2	Products	5-43
5.3.4.2.1	Reinforced Concrete Manholes and Accessories	5-43
5.3.4.2.2	Sewer Pipe to Manhole Connections	5-44
5.3.4.2.3	Castings	5-45
5.3.4.2.4	Frame Chimney Seal	5-45
5.3.4.3	Execution	5-46
5.3.4.3.1	Installation	5-46
5.3.4.4	Sanitary Manhole Testing	5-46
5.3.4.4.1	Vacuum Testing	5-46
5.3.4.5	Final Acceptance	5-48
5.3.5	Pressure Pipe - Sanitary	5-48
5.3.5.1	General	5-48
5.3.5.1.1	Description	5-48
5.3.5.1.2	Quality Assurance	5-48
5.3.5.1.3	Submittals	5-48
5.3.5.2	Products	5-49
5.3.5.2.1	Ductile Iron Pipe	5-49
5.3.5.2.2	Polyvinyl Chloride Pipe (PVC) C-900/C-905	5-50
5.3.5.2.3	Air Release Valves	5-51
5.3.5.3	Execution	5-52
5.3.5.3.1	Alignment and Grade	5-52
5.3.5.3.2	Trenching	5-52
5.3.5.3.3	Pipe Laying	5-53
5.3.5.3.4	Joint Assembly	5-54
5.3.5.3.5	Embedment and Backfill for Pressure Sewer Main	5-54
5.3.5.3.6	Thrust Restraint	5-54
5.3.5.3.7	Air Relief	5-55
5.3.5.3.8	Testing	5-56
5.3.6	Submersible Lift Station	5-57
5.3.6.1	General	5-57
5.3.6.1.1	Description	5-57

5.3.6.1.2	Quality Control.....	5-58
5.3.6.1.3	Submittals.....	5-58
5.3.6.1.4	System Start-Up and Testing.....	5-59
5.3.6.1.5	Operation and Maintenance Start-Up Support - Training.....	5-59
5.3.6.1.6	Delivery and Storage.....	5-59
5.3.6.2	Products.....	5-59
5.3.6.2.1	Operating Conditions.....	5-59
5.3.6.2.2	Pumps.....	5-60
5.3.6.2.3	Pump Removal System.....	5-60
5.3.6.2.4	Pre-Cast Concrete Wet Well.....	5-61
5.3.6.2.5	Pre-Cast Concrete Valve Vault.....	5-62
5.3.6.2.6	Interior Coating for Wet Well (If Required).....	5-62
5.3.6.2.7	Hatches.....	5-64
5.3.6.2.8	Ductile Iron Piping and Fittings.....	5-65
5.3.6.2.9	Valves.....	5-66
5.3.6.2.10	Vents.....	5-68
5.3.6.2.11	Strain Relief Grips.....	5-68
5.3.6.2.12	Pressure Gauges.....	5-68
5.3.6.2.13	Specialty Tools.....	5-68
5.3.6.2.14	Drain Piping and Clean-outs.....	5-69
5.3.6.2.15	Concrete Pad and Control Panel.....	5-69
5.3.6.2.16	Lighting.....	5-69
5.3.6.2.17	Mechanical Building.....	5-70
5.3.6.3	Execution.....	5-71
5.3.6.3.1	Excavation for Structures.....	5-71
5.3.6.3.2	Backfill.....	5-71
5.3.6.3.3	Precast Structure Installation.....	5-71
5.3.6.3.4	Piping Installation.....	5-72
5.4	Technical Specifications - Water.....	5-72
5.4.1	Construction Specifications.....	5-72
5.4.1.1	General.....	5-72
5.4.1.1.1	Description.....	5-72
5.4.1.1.2	Quality Assurance.....	5-73
5.4.1.1.3	Product Delivery, Storage, and Handling.....	5-73

5.4.1.2	Products.....	5-73
5.4.1.2.1	General	5-73
5.4.1.2.2	Buried Water Main Pipe and Fittings.....	5-73
5.4.1.2.3	Casing Pipe for Water Mains	5-77
5.4.1.2.4	Valves.....	5-78
5.4.1.2.5	Valve Boxes	5-80
5.4.1.2.6	Fire Hydrants	5-81
5.4.1.2.7	Tapping Sleeves	5-83
5.4.1.2.8	Tapping Saddles	5-83
5.4.1.2.9	Flange-Mechanical Joint Adaptors.....	5-84
5.4.1.2.10	Restrained Expansion Couplings.....	5-84
5.4.1.2.11	Polyethylene Wrap	5-84
5.4.1.2.12	Air and Vacuum Valve Chambers.....	5-85
5.4.1.2.13	Grout.....	5-85
5.4.1.2.14	Location (Tracing) Wire.....	5-85
5.4.1.3	Execution	5-85
5.4.1.3.1	Inspection	5-85
5.4.1.3.2	Laying of Water Mains.....	5-85
5.4.1.3.3	Setting Valves, Valve Boxes, and Fire Hydrants.....	5-87
5.4.1.3.4	Connecting to Existing Mains.....	5-87
5.4.1.3.5	Jointing.....	5-88
5.4.1.3.6	Restraining and Supports.....	5-90
5.4.1.3.7	Air and Vacuum Valve Chambers.....	5-90
5.4.1.3.8	Hydrostatic Testing	5-90
5.4.1.3.9	Flushing.....	5-90
5.4.1.3.10	Disinfection	5-91
5.4.1.3.11	Existing Valve Operation.....	5-93
5.4.1.3.12	Completion Scheduling.....	5-93

SECTION 6: Standard Details..... 6-1

List of Figures

Figure 1-1: Variance Request Form	1-16
Figure 3-1 QC/QA Submittal Checklist	3-23
Figure 3-2 Minimum Sewer Plan Submittal Checklist	3-24
Figure 3-3 Minimum Water Plan Submittal Checklist	3-25
Figure 3-4 Sanitary Sewer Early Coordination Checklist	3-26
Figure 3-5 Water Early Coordination Checklist	3-27
Figure 5-1 Contractor Pre-Qualification Questionnaire	5-4
Figure 5-2: Sewer Field Decision Escalation Process	5-20
Figure 5-3: Water Field Decision Escalation Process	5-21
Figure 6-1: Detail WW-01 Standard Precast 48” Manhole	6-2
Figure 6-2: Detail WW-02 Standard Precast Concrete 60” Manhole	6-3
Figure 6-3: Detail WW-03 Standard Precast Concrete 72” Manhole	6-4
Figure 6-4: Detail WW-04 Precast External Drop Manhole	6-5
Figure 6-5: Detail WW-05 Standard Manhole Backfill	6-6
Figure 6-6: Detail WW-06 Standard Manhole Benches and Channels	6-7
Figure 6-7: Detail WW-07 Standard Casting Adjustment and Grade Rings	6-8
Figure 6-8: Detail WW-08 Stub-Out at Manhole	6-9
Figure 6-9: Detail WW-09 Internal Drop Connection to Existing Manhole	6-10
Figure 6-10: Detail WW-10 New Pipe Connection to Existing Manhole	6-11
Figure 6-11: Detail WW-11 New Manhole on Existing Pipe	6-12
Figure 6-12: Detail WW-12 Proposed Sanitary Sewer and Existing Water Line Crossing	6-13
Figure 6-13: Detail WW-13 Rigid Sanitary Sewer Pipe Bedding and Backfill Near or Under Pavement	6-14
Figure 6-14: Detail WW-14 Rigid Sanitary Sewer Pipe Bedding and Backfill Outside of Pavement	6-15
Figure 6-15: Detail WW-15 Non Rigid Sanitary Sewer Pipe Bedding and Backfill Near or Under Pavement	6-16
Figure 6-16: Detail WW-16 Non Rigid Sanitary Sewer Pipe Bedding and Backfill Outside of Pavement	6-17
Figure 6-17: Detail WW-17 Lateral Sewer Connection Layout (Residential)	6-18
Figure 6-18: Detail WW-18 Lateral Sewer Connection Layout (Commercial)	6-19
Figure 6-19: Detail WW-19 Standard Sanitary Cleanout in Paved Areas	6-20
Figure 6-20: Detail WW-20 Standard Sanitary Cleanout in Unpaved Areas	6-21
Figure 6-21: Detail WW-21 Final Backfill and Traffic Influence Detail	6-22
Figure 6-22: Detail WW-22 Shallow Sanitary Service Connection	6-23

Figure 6-23: Detail WW-23 Deep Sanitary Service Connection	6-24
Figure 6-24: Detail WW-24 Sanitary Service Connection to Existing Pipe	6-25
Figure 6-25: Detail WW-25 Inside Drop Stainless Steel Adjustable Clamping Bracket	6-26
Figure 6-26: Detail DW-01 Typical Water Main Trench	6-27
Figure 6-27: Detail DW-02 Tracing Wire Detail	6-28
Figure 6-28: Detail DW-03 Gate Valve Installation Detail.....	6-29
Figure 6-29: Detail DW-04 Fire Hydrant Assembly	6-30
Figure 6-30: Detail DW-05 Anchor Coupling Detail	6-31
Figure 6-31: Detail DW-06 Air Relief Assembly (Non-Traffic Rated).....	6-32
Figure 6-32: Detail DW-07 Pressure Tapping Detail	6-33
Figure 6-33: Detail DW-08 Expansion Coupling (4" Through 12")	6-34
Figure 6-34: Detail DW-09 Restrained Joints (Mechanical Joint and Slip Joint Pipes)	6-35
Figure 6-35: Detail DW-10 Typical Restraining For Valves and Reducers	6-36
Figure 6-36: Detail DW-11 Typical Offset Assembly (Storm or Sanitary Crossing)	6-37
Figure 6-37: Detail DW-12 Typical Channel Crossing.....	6-38
Figure 6-38: Detail DW-13 Water Line Location for Cul-De-Sac (8" or 12" Pipe)	6-39
Figure 6-39: Detail DW-14 Water Line Location for Cul-De-Sac (4" Pipe)	6-40
Figure 6-40: Detail DW-15 Typical Commercial Service Connections (Same Side of Roadway)	6-41
Figure 6-41: Detail DW-16 Typical Commercial Service Connection (Road Boring Required).....	6-42
Figure 6-42: Detail DW-17 Typical Jack and Bore Casing Pipe	6-43
Figure 6-43: Detail DW-18 Typical Casing Spacers	6-44
Figure 6-44: Detail DW-19 Typical Casing End Seals.....	6-45
Figure 6-45: Detail DW-20 ¾" or 1" Meter Service Connection	6-46
Figure 6-46: Detail DW-21 2" Tap Detail	6-47
Figure 6-47: Detail DW-22 2" Meter Service Connection	6-48
Figure 6-48: Detail DW-23 4" Meter Service Connection	6-49
Figure 6-49: Detail DW-24 6" Meter Service Connection	6-50
Figure 6-50: Detail DW-25 Fire Service Connection	6-51
Figure 6-51: Detail DW-26 Traffic Rated Meter Pit.....	6-52
Figure 6-52: Detail DW-27 4" Meter Pit.....	6-53
Figure 6-53: Detail DW-28 6" Meter Pit.....	6-54
Figure 6-54: Detail DW-29 Chlorination / Disinfection Tap	6-55
Figure 6-55: Detail DW-30 Permanent Blow-Off Assembly with 2" Corporation Stop.....	6-56

Figure 6-56: Detail DW-31 Temporary Blow-Off Assembly with Saddle 6-57

Figure 6-57: Detail DW-32 Temporary Blow-Off Assembly with Gate Valve..... 6-58

Figure 6-58: Detail DW-33 Automatic Flushing Device with Gate Valve (Eclipse 9800) 6-59

Figure 6-59: Detail DW-34 Automatic Flushing Device with Gate Valve (Eclipse 9400) 6-60

Figure 6-60: Detail DW-35 Automatic Flushing Device with 2” Corporation Stope (Eclipse 9400) 6-61

Figure 6-61: Detail DW-36 Automatic Flushing Device Notes 6-62

Figure 6-62 Sanitary Lift Station Detail 6-63

Figure 6-63: Sanitary Lift Station Control Building 6-64

List of Tables

Table 4-1 Wastewater Design Flows..... 4-38

Table 4-2 Minimum Allowable Slopes 4-39

Table 4-3 Casing Pipe Minimum Thickness..... 4-45

Table 4-4 Demand Factors..... 4-77

Table 4-5 Maximum Velocity 4-79

Table 4-6 Roughness Coefficients..... 4-80

Table 4-7 Casing Pipe..... 4-83

Table 4-8 Maximum Allowable Valve Spacing Intervals 4-90

Table 5-1: Time Required for a 1.0 PSIG Pressure Drop For Air Testing Pipe 5-42

Table 5-2: Time Required to Maintain Vacuum In Manhole 5-47

Table 5-3: Ductile Iron Pipe Pressure Classes 5-73

Table 5-4: Combination Air and Vacuum Relief Valves 5-79

Table 5-5: Allowable Pipe Deflection (Push On Joint) 5-88

Table 5-6: Mechanical Joint Bolt Torque Range 5-89

Table 5-7: Pipe Deflection (Mechanical Joint) 5-89

Table 5-8: Required Flow for Flushing Velocity 5-91

Table 5-9: Chlorine Required Per 100 Feet of Pipe..... 5-92

SECTION 1: INTRODUCTION

1.1 Purpose

This Handbook is a guide for the planning, design, and construction of sanitary sewer collection systems and water distribution systems and related facilities for projects that are initiated by private entities such as land developers, private property owners or other such parties, and that require Evansville Water & Sewer Utility (EWSU) approval and/or acceptance. This Handbook presents the information necessary for the aforementioned private entities (herein referred to as 'Developer') to plan and construct facilities that fall under the jurisdiction of the EWSU. Customers, developers and their design consultants should familiarize themselves with this document prior to commencing work on proposed water and sewer projects. Familiarity with these requirements will enable the Developer and his or her design consultants to efficiently plan and execute their projects and minimize the occurrence of unnecessary activities.

In general, this Handbook:

- Enumerates general design standards that have been either commissioned or authorized by local and state agencies to facilitate compliance with the applicable local, state and federal regulations;
- Identifies submittal requirements and procedures for the review of water and sewer infrastructure projects;
- Serves as a reference document for EWSU staff, professional design consultants and Developers to define review procedures and requirements; thus facilitating the efficient approval of said infrastructure projects;
- Identifies and provides standards for the construction and installation of sanitary sewer collection systems and potable water distribution systems; and
- Provides uniformity in design and construction of projects within the EWSU service area. This is important to ensure projects are easily maintainable, are reliable and durable.

1.2 Description and Use of the Handbook

This Handbook identifies requirements to be used in the planning, design, permitting and construction of projects within EWSU service area.

This Handbook is not intended to serve as a step-by-step design procedure nor can it address every situation that may arise. The application of sound engineering principles and judgment combined with the information contained herein are necessary to complete the planning, design, and preparation of related construction documents for wastewater and potable water projects.

1.2.1 Compliance with Other Standards

Compliance with this Handbook does not eliminate the need to comply with other applicable City, County, State and Federal ordinances and regulations. These may include, but are not limited to:

- Submission and approval of preliminary and final subdivision plats

- Construction in a Floodway permits
- IDEM permits for sanitary and water facilities construction
- Road right-of-way, building and zoning permits
- Construction inspections
- Appeals and similar matters

1.2.2 Conflicting Standards

The provisions of this Handbook shall be deemed as additional requirements to minimum standards required by other applicable ordinances and standards. In the case of conflicting requirements, the most restrictive shall apply.

1.3 Structure of the Handbook

This Handbook contains five chapters and is structured as follows:

Section 1 - Introduction provides a purpose statement and covers general topics. This section also contains a list of commonly used abbreviations and definitions as well as a variance procedure for deviation from the standards contained within this handbook.

Section 2 - Customers outlines general information related to existing customers, including customer and EWSU responsibilities, meters, services, meter reading, sewer connections, shut-offs, complaint resolution, etc.

Section 3 - Developers outlines standards and policies for the process of application, review, plan approval, construction and final acceptance of water or sewer extensions and large services. This section provides detail on navigating the permit process and details expectations.

Section 4 - Engineers outlines standards and policies for the design of development projects, including water and sewer main extensions and water and sewer services. This section has a purpose of providing guidance to the Engineer for surveying and design.

Section 5 - Contractors provides the requirements for a new contractor to be approved for construction with the EWSU. It also outlines the standard specifications for the construction of extensions and improvements to the sanitary sewer collection system and the potable water distribution system.

Section 6 – Details provides standard detail drawings for construction of water and sewer facilities within the EWSU system.

1.4 Updates to the Handbook

This Handbook is intended to be a dynamic document. As design criteria and technology evolve, the Handbook will require revisions and improvements. Revisions to the document will have a public hearing for input and comment and then will move to formal approval by the Evansville Water and Sewer Utility Board of Directors. As approved changes are made, supplements or revisions will be posted and updated at the EWSU Website.

1.5 Enforcement & Penalties

Although there is no formal enforcement and penalty procedure, failure to comply with requirements set forth in

this Handbook may impact the Developer’s project in various ways. These impacts may include, but are not limited to:

- Delayed or prolonged review times,
- Delayed plan approval and/or permission to begin construction,
- Denial of an application,
- Stop work orders,
- Denial of Certificate of Occupancy
- Denial of a request for Acceptance for Maintenance,
- Exercising of the Developer’s Letter of Credit.

1.6 Topics Not Included in the Standards

Topics not included in this Handbook that are within the jurisdiction of EWSU include:

- Wastewater treatment,
- Water treatment,
- Design and construction of Storm Water projects.

1.7 Resource Documents for Reference

- The following documents, standards and manuals were used as references in the development of the Standards:
- Existing EWSU Handbook;
- Model standards and documents from the City of Ft. Wayne, Indiana;
- Model Specifications for Water & Sewer Main Construction in Indiana;
- “Draft” Storm Water Design and Specification Manual, Green Infrastructure Supplemental Storm Water Document;
- Great Lakes-Upper Mississippi River Board of State Public Health and Environmental Managers, Recommended Standards for Wastewater Facilities, latest edition. (Also referred to as Ten State Standards for Wastewater Facilities);
- Great Lakes-Upper Mississippi River Board of State Public Health and Environmental Managers, Recommended Standards for Water Works, latest edition. (Referred to as Ten State Standards for Water Works);
- Indiana Department of Environmental Management (IDEM) Regulations including Title 327 of the Indiana Administrative Code (327 IAC);
- Indiana Department of Transportation (INDOT) Standard specifications, latest edition.

1.8 Abbreviations and Definitions

1.8.1 Purpose

The purpose of this section is to define abbreviations and terms used throughout these Development Standards. This chapter covers the intent and meaning of the referenced abbreviations and terms.

1.8.2 Abbreviations

<u>AASHTO</u>	American Association of State Highway and Transportation Officials
<u>ADA</u>	Americans with Disabilities Act
<u>ADAAG</u>	Americans with Disabilities Act Accessibility Guidelines
<u>ADF</u>	Average Daily Flow
<u>AG</u>	Air Gap (Backflow Prevention)
<u>ANSI</u>	American National Standards Institute
<u>ASCE</u>	American Society of Civil Engineers
<u>ASHRAE</u>	American Society of Heating, Refrigerating and Air-Conditioning Engineers
<u>ASTM</u>	ASTM International (formerly American Society of Testing and Materials)
<u>AVB</u>	Atmospheric Vacuum Breaker (Backflow Preventer)
<u>AWG</u>	American Wire Gauge
<u>AWWA</u>	American Water Works Association
<u>CERCLA</u>	Comprehensive Environmental Response, Compensation and Liability Act of 1980 (commonly known as Superfund)
<u>CIPP</u>	Cured-In-Place Pipe
<u>CSI</u>	Construction Specifications Institute
<u>DBH</u>	Tree Diameter Breast Height
<u>DC</u>	Double Check Valve (Backflow Preventer)
<u>DI</u>	Ductile Iron Pipe
<u>FGCC</u>	Federal Geodetic Control Committee
<u>GIS</u>	Geographic Information System
<u>GPD</u>	Gallons per Day
<u>GPS</u>	Global Positioning System
<u>HDPE</u>	High Density Polyethylene

<u>HP</u>	Horsepower
<u>I/I</u>	Infiltration and Inflow
<u>IAC</u>	Indiana Administrative Code
<u>IAPMO</u>	International Association of Plumbing and Mechanical Officials
<u>IBC</u>	International Building Code
<u>IDEM</u>	Indiana Department of Environmental Management
<u>IDNR</u>	Indiana Department of Natural Resources
<u>IFC</u>	Indiana Fire Code
<u>IMUTCD</u>	Indiana Manual on Uniform Traffic Control Devices
<u>INDOT</u>	Indiana Department of Transportation
<u>IPC</u>	Indiana Plumbing Code
<u>IURC</u>	Indiana Utility Regulatory Commission
<u>LS</u>	Land Surveyor
<u>NAVD88</u>	North American Vertical Datum of 1988
<u>NEC</u>	National Electric Code (NFPA 70)
<u>NECA</u>	National Electrical Contractors Association
<u>NEMA</u>	National Electrical Manufacturers Association
<u>NFPA</u>	National Fire Protection Association
<u>NGVD29</u>	National Geodetic Vertical Datum of 1929
<u>NOAA</u>	National Oceanic and Atmospheric Administration
<u>NPSH</u>	Net Positive Suction Head
<u>NTS</u>	Not To Scale
<u>OSHA</u>	Occupational Safety and Health Administration
<u>PDF</u>	Portable Document Format
<u>PE</u>	Professional Engineer
<u>PSA</u>	Professional Service Agreement
<u>PSI</u>	Pounds per Square Inch
<u>PVB</u>	Pressure Vacuum Breaker (Backflow Preventer)

<u>PVC</u>	Polyvinyl Chloride
<u>RCP</u>	Reinforced Concrete Pipe
<u>ROW</u>	Right-Of-Way
<u>RP</u>	Reduced Pressure Principle (Backflow Preventer)
<u>RPR</u>	Resident Project Representative
<u>SDR</u>	Standard Dimension Ratio
<u>SWMM</u>	EPA Storm Water Management Model
<u>SWPPP</u>	Stormwater Pollution Prevention Plan
<u>TBM</u>	Temporary Bench Marks
<u>TCP</u>	Temporary Project Control Points
<u>TDH</u>	Total Dynamic Head
<u>UL</u>	Underwriters Laboratories, Inc.
<u>VCP</u>	Vitrified Clay Pipe
<u>VFD</u>	Variable Frequency Drive
<u>W</u>	Watt
<u>WPCP</u>	Water Pollution Control Plant

1.8.3 Definitions

Adjusting Ring A cylindrical ring, usually comprised of concrete, secured on top of a manhole upon which the frame will rest

Air-Gap The unobstructed vertical distance, through the free atmosphere, between the lowest opening from any pipe or faucet supplying water to a tank, plumbing fixture, or other device and the floor level rim of the receptacle. An air-gap is an approved method for backflow prevention.

Applicant Person or entity seeking service.

Atmospheric Vacuum Breaker A backflow prevention device consisting of an air inlet valve, a check seat and an airport.

Average Daily Flow Average 24-hour dry weather flow, including a nominal amount of infiltration, within a sewer

Backfill Earth and/or other material used to replace material removed from trenches or other excavations during construction activities. The backfill lies above the pipe bedding

Backflow Flow of water or contaminants into the public water supply distribution system from a source other than the public water supply.

Backflow Prevention Device A device to prevent the flow of water or contaminants into the public water supply distribution system that has been approved for use by IDEM or EWSU.

Bedding The fractured face stone which encases the sewer pipe to a minimum depth above and below the barrel of the pipe. The bedding serves as the pipe support

Board Board of Directors of the Evansville Water and Sewer Utility, governing body of the Utility.

Booster Pump Pump installed on a pipeline to increase water pressure.

Building Sewer Private sewers which connect building plumbing to public sewers. Building sewers normally begin outside the building foundation

Buoyancy The act of supporting a floating body, including the tendency to float an empty pipe or structure by exterior hydraulic pressure

Capital Projects Projects designed and constructed under the management of EWSU Engineering.

Check Valve Mechanical backflow device. A valve provided with a disk, hinged on one edge, so that it opens in the direction of the normal flow and closes with a reverse flow.

City The City of Evansville, Indiana.

Cleanout A pipe or some other opening through which a device may be run to unplug a sewer

Clear Water Drainage Non-polluted rain water, roof drainage, etc.

Collar A monolithic concrete encasement of sanitary cleanout casting in pavement

Collector Sewer Sewer that is primarily installed to receive wastewater directly from building sewer connections and convey the wastewater to an interceptor line

Combined or Combination Sewer A sewer which carries storm, surface and groundwater runoff as well as wastewater. New installations must have separate storm and sanitary sewers.

Concrete Pipe Includes reinforced concrete pipe, horizontal and vertical elliptical concrete pipe, concrete arch pipe and concrete box sections

Connection Tap-In A tap to the main sanitary sewer or property line cleanout for the building being served

Consumer The person(s), firm, corporation, or association having interest, either legal or equitable, either as owner, tenant, or occupant in any premise which is or is to be supplied with water or sewer service by the Utility.

Contamination An impairment of the quality of the public water supply by the presence of any foreign substance (organic, inorganic, radiological, or biological) to a degree which creates a hazard to the public health through poisoning or through the spread of disease or create a nuisance condition such as discoloration, staining, tastes, or odors.

Cover Up See backfill.

Cross Connection Any physical arrangement, including cross connection control devices not in working order, whereby a public water supply distribution system is directly connected, either continuously or intermittently, with any secondary source of supply, sewer, drain, conduit, pool, piping, storage reservoir, plumbing fixture, or other device which contains, or may contain, and is capable of imparting to the public water supply, contaminants, contaminated water, sewage, or other waste or liquid of unknown or unsafe quality.

Cross Connection Control Device Any device or assembly, approved by the commissioner of IDEM for construction on or installation in water supply piping, which is capable of preventing contaminants from entering the public water supply distribution system.

Cross Connection Control Device Inspector Person who has successfully completed training in testing and inspection of cross connection control devices from a training provided approved by the commissioner of IDEM, has received a registration number from the commissioner, and who has not been notified by the commissioner that the registration number has been revoked in accordance with section 11 (b) of IDEM Rule 327 IAC 8-11.

Cross Connection Hazard Any facility which, because of the nature and extent of activities on the premises or the materials used in connection with the activities or stored on the premises, would present an immediate or potential danger of health hazard to customers of the public water supply should backflow occur.

Crown The top or highest point of the internal surface of a conduit or sewer pipe.

Curb Stop (Service Valve) A fitting inserted in the service pipe in the right-of-way near the property line for turning on and shutting off water to the premises supplied or to be supplied.

Customer Service Line The pipeline from the public water supply to the first tap, fixture, receptacle, or other point of customer water use; or to the first secondary source of supply, or pipeline branch in a building.

Cycle Period The monthly schedule for meter reading and billing.

Developer Any person, association, corporation, or entity desiring new water and/or sanitary sewer service for premises under their control.

Development Any man-made change to improved or unimproved real estate, including but not limited to, buildings, or other structures, filling, grading, paving, excavation, substantial improvements, placement of mobile homes, subdivision of land

Double Check Valves A device or assembly composed of two (2) tightly closing shut-off valves surrounding two (2) independently acting check valves, with four (4) test cocks, one (1) upstream of the four (4) valves and one (1) between each of the four check and shut-off valves.

Easement A grant by a property owner to the general public and/or public utility or utilities (or quasi-public utilities) for the use of land for a specifically stated purpose or purposes

Encasement The enclosing or surrounding of a conduit with concrete or other suitable material

Evansville Water and Sewer Utility (EWSU) A branch of the City of Evansville government having authority over all potable water and sanitary sewer assets within its jurisdiction

Flexible Pipe Comprises all pipe materials other than concrete pipe, including but not limited to ductile iron pipe, polyvinylchloride pipe, high density polyethylene pipe, fiberglass reinforced pipe, and polypropylene pipe

Force Main A pressurized pipe that conveys flow from the discharge side of a pump.

Free Standing Structures Unattached to a supporting unit, not by a walkway, closed or open (tunnel or canopy).

Grade The inclination or slope of a conduit or natural ground surface usually expressed in terms of the percentage the vertical rise (or fall) bears to the corresponding horizontal distance.

Grease Interceptor Device which collects organic substances including fats, vegetable and mineral oils, waxes, fatty acids from soaps, and other long-chain hydrocarbons before they enter the sewer system, thus reducing the risk of blockages in sewers

Hook Up See Tap In.

Hydraulic Grade Line Measure of pressure head available at specific points within a sewer system. The hydraulic grade line is a line connecting the points to which the liquid would rise at various places along any pipe if piezometer tubes were inserted in the liquid

Infiltration Groundwater that enters the sewer system via such means as pipe cracks, joints, connections, or defects in manhole structures

Inflow Surface water which enters the sanitary sewer system via an improper drain connection (foundation drain, roof drain, yard drain, inlet structure, storm sewer cross connection, or sump pump) or from sources such as leaks through manhole cover

Interceptor Sewer Principal sewer to which collector sewers are tributary. Interceptor sewers convey the wastewater to treatment or other disposal facilities

Invert The bottom or lowest elevation of the internal cross-section of a conduit or sewer pipe

Inverted Siphon A gravity sewer which is designed to drop below the hydraulic grade line

Lateral A service line off of a main to the premises being served.

Lift station Any arrangement of pumps, piping, valves, and controls that conveys wastewater to or over a higher elevation

Main A pipe owned by the Utility for transmitting sewage to a treatment facility.

Mandrel Test Testing required to check sewer pipe for excess deflection after installation.

Manhole Sanitary sewer confined space through which a person may enter to gain access to an underground sanitary sewer

Minimum Sewer Charges The minimum based upon minimum water usage

Monolithic Concrete structure cast as a single piece and formed without joints or seams

Municipal Code A system of principles, rules and laws approved by the City Council.

Non-Capital Project Variety of projects managed by Development Services including, but not limited to, development, redevelopment, private development, and changes to existing roads.

Non-Potable Water Not satisfactory for human consumption

NPDES National Pollutant Discharge Elimination System. Permit for discharge.

Ordinance Authoritative rules and laws enacted by the City Council.

Peak Hourly Flow The largest volume of flow to be received during a one hour period expressed as a volume per unit time

Permanent Easement A permanent right-of-way to use a described parcel of land for the purposes to construct, operate, control, maintain, reconstruct, or remove a water main and appurtenances along, under, and across said easement.

Permit Written permission from agency with authority to control operation

Population, Equivalent A hypothetical number of persons for which flow contributions are calculated

Population Build-Out The actual (equivalent) population that exists or would exist when an area is fully developed

Potable Water Considered satisfactory for human consumption.

POTW Publicly Operated Treatment Works

Precast A concrete item which is formed or molded

Premises A tract of land including its buildings.

Pressure Vacuum Breaker A device or assembly containing an independently operating internally loaded check valve and an independently operating loaded air inlet valve located on the downstream side of the check valve for relieving a vacuum or partial vacuum in a pipeline.

Pre-Treatment Treatment of wastewater at its source before discharge to the municipal collection system.

Private Fire Service A privately owned arrangements of pipes, fixtures and devices designed for stand-by service and from which water is taken only for the extinguishment of fires.

Private Sewer Pipe owned and maintained by a private person or company which conveys wastewater

Private Water Main Water main owned and operated by a private person(s), company or other non-public entity.

Program Manager A senior staff member of EWSU with designated authorities and responsibilities specific to their field of discipline.

Project Manager A staff member of EWSU responsible for the management and coordination of activities required for the completion of a project owned by or affecting EWSU facilities

Project Manual A collection of written construction documents and project requirements which typically includes; bidding requirements, contract forms and supplements, contract conditions, and specifications.

Project Record Documents Include construction submittals, record drawings, record specifications, addenda, contract modifications, photographs, start-up logs, test reports, certifications, and other documents which are assembled by the contractor.

Protection Device Any of the following devices: air gap separation; approved double check valve assembly; approved reduced pressure principle backflow prevention assembly; or atmospheric or pressure vacuum breaker.

Public Water Main Pipe used to convey water to which all owners of abutting property have equal rights to and is controlled and maintained by the City of Evansville or other public authority and regulated by the Indiana Utility Regulatory Commission.

Public Sewer Pipe used to convey wastewater which all owners of abutting property have equal rights to and is controlled and maintained by the City of Evansville or other public authority.

Punch List A list of corrections to be made and items to address before a project can be accepted

Reduced Pressure Principle Backflow Preventer A device composed of two (2) tightly closing shut-off valves surrounding two (2) independently acting pressure reducing check valves that, in turn, surround an automatic pressure differential relief valve, and four (4) test cocks, one (1) upstream of the five (5) valves and one (1) between each of the four (4) check and shut-off valves. The check valves effectively divided the structure into three (3) chambers; pressure is reduced in each downstream chamber allowing the pressure differential relief valve to vent the center chamber to atmosphere should either or both check valves malfunction.

Right-of-Way A general term denoting land, property or interest therein, usually in a strip of land acquired for or devoted to the construction of a highway, road or street that will include the travelled way, shoulders, roadsides, auxiliary lanes, medians, border areas, park strips, sidewalks, curbs, gutters, and fronting roads

Saddle A fitting (Tap In) for connection to a main

Sand/Oil Separators Device designed to remove sand and oil from wastewater prior to discharge to main line sewer

Sanitary Sewer A sewer which carries domestic and industrial sanitary wastewater and to which storm water, surface water, ground water, roof runoff, subsurface drainage, cooling water or unpolluted industrial process waters are not intentionally admitted.

Secondary Source of Supply Any well, spring, cistern, lake, stream, or other water source, intake structure, pumps, piping, treatment units, tanks, and appurtenances used, either continuously or intermittently, to supply water other than from public water supply to the customer. This include tanks used to store water to be used only for firefighting, process water, etc., even though the water contained therein is supplied from the public water supply.

Service Area A geographical area served by a public utility or sewage collection system

Sewer Pipe used to convey wastewater to a treatment facility

Springline The horizontal centerline of a conduit or sewer pipe

Standards The City of Evansville City Utilities Design Standards Manual. The requirements for the design and construction of drainage facilities within Evansville as contained herein

Storm Sewer A sewer pipe that carries rain water and surface water, street wash and other wash waters, or drainage, but excludes domestic wastewater and industrial wastes. It also can be called a storm drain.

Submersible Pump A pump capable of being fully placed beneath a water surface

Tap In A connection to a main

Transportation Engineering Services A department of the City of Evansville that provides engineering support, design and construction management for the transportation system.

Utility Whenever the word Utility or Department appears herein, it shall mean the Evansville Water and Sewer Utility.

Wastewater The water-carried wastes from residences, business buildings, institutions and industrial establishments, singularly or in any combination, together with such ground, surface and storm waters as may be present.

Water Distribution System (Public) Network of water mains and appurtenances that deliver potable water from the filtration plant to the user.

Water Main Water conduits three inches (3") in diameter and larger, together with all appurtenances, any necessary vales, fire hydrants, and associated materials receiving potable water and distributing it to more than one customers.

Water Main Extension Extension of the distribution system which may service new customers.

Water Service The portion of pipe situated between and including the tap and the curb stop, which is installed by City Utilities or a contractor and maintained by City Utilities after the expiration of any applicable maintenance bond.

Wet Well A short-term storage tank containing a pump or pump suction into which wastewater is conveyed

Working Days Days when employees of the Evansville Water and Sewer Utility work, excluding weekends and holidays.

1.9 Variances

1.9.1 Purpose

This chapter outlines the requirements, processes and procedures for acquiring variances from this Handbook. Variances from this Handbook shall be considered on a project-by-project basis. A variance may be granted if an applicant makes a substantial showing that:

- The given standard is infeasible or unreasonably burdensome;
- An alternative plan submitted by the applicant will achieve the same objective and purpose as compliance with the minimum requirements contained in the Handbook;

- The alternative plan will not increase the direct annual and/or life cycle cost of operation and/or maintenance to the EWSU; and
- The alternative plan does not violate any other permits, statutes or regulatory requirements.

Cost to the applicant shall not be the sole factor used to determine whether the design standards are infeasible or unreasonably burdensome.

1.9.2 Authority to Waive Requirements

The Evansville Water and Sewer Utility Board of Directors has the sole authority to modify or waive any requirement found in this Handbook.

1.9.3 Types of Variances

There are two types of variances:

Technical Variance

A Technical Variance applies to deviations from the submittal and review process and/or the requirements outlined in Chapters 1 or 2 of this Handbook.

Material Variance

A Material Variance applies to deviations from the approved materials or methods as specified in Chapters 3 through 6 of this Handbook.

1.9.4 Technical Variance Procedures

Technical Variances shall use the following procedure:

1.9.4.1 Variance Request Form.

All variance applications shall be made using the Variance Request Form. The form must be fully completed and include all attachments to substantiate and demonstrate the requirements listed above. The form must be sealed by a Professional Engineer licensed in the State of Indiana.

- It is the responsibility of the applicant to understand the requirements of this Handbook and to know when a variance is required.
- Where review of the submittal package identifies that a variance is needed, the applicant will be notified through the review comment process. The timely submittal of the variance request is encouraged to avoid delays in the issuance of permits.

1.9.4.2 Variance Decision.

- Variance requests submitted as part of a standard submittal package will be responded to within the timeframes established for review listed herein. Responses include approvals, denials or the need for additional review time.
- Variance requests submitted as part of a standard submittal package that are incomplete will be returned to the applicant. When the complete application is received, the request will be decided upon within fourteen (14) calendar days.

- Variance requests received outside the standard submittal package will be decided upon within fourteen (14) calendar days. Incomplete variance requests will be returned to the applicant. When the complete application is received, the request will be decided upon within fourteen (14) calendar days.
- The appropriate EWSU Staff member from each field of discipline will reply in writing to the applicant within the timetables listed in this section.

1.9.4.3 Technical Variance Appeals

Any person affected by the exercise of the discretionary authority of the EWSU Engineering Staff, including a decision to deny or partially deny a Technical Variance, and who objects to the decision made is entitled to appeal the decision. The appeal procedure is as follows.

1.9.4.3.1 Appeal Filing

The appeal of denied or partially denied variance decision shall be filed with the Deputy Director of Utilities – Engineering in writing within twenty one (21) calendar days following the date of the decision.

1.9.4.3.2 Appeal Review

Within thirty (30) calendar days of the submittal, the Deputy Director of Utilities - Engineering Administration shall make a final ruling on the variance request. The applicant can request an in-person meeting with the Deputy Director as part of the appeal process. The decision of the Deputy Director will be provided directly to the applicant and to the appropriate EWSU Capital Program Manager.

1.9.5 Material Variance Procedures

Material variance requests shall use the following procedure:

1.9.5.1 Variance Request Form

All variance applications shall be made using the Variance Request Form. The form must be fully completed and include all attachments to substantiate and demonstrate the requirements listed herein.

1.9.5.2 Variance Decision.

The Capital Projects Manager for the appropriate EWSU field of discipline will respond in writing with an estimate of the time required to review the request. The required time will be determined on a case-by-case basis.

Depending on the nature of the Material Variance requests, formal action by the Utility Board may be required. The review requirements will be determined on a case-by-case basis depending on the complexity of the request. Any costs associated with the variance request may be deemed the responsibility of the applicant.

1.9.5.3 Material Variance Appeals

Any person affected by the exercise of the discretionary authority of the EWSU, including a decision to deny or partially deny a variance, and who objects to the decision made is entitled to appeal the decision. The appeal procedure is as follows:

1.9.5.3.1 Appeal Filing

The appeal of denied or partially denied variance decision shall be filed with the Deputy Director of Utilities – Engineering in writing within twenty one (21) calendar days following the date of the decision.

1.9.5.3.2 Appeal Review

Within thirty (30) calendar days of the submittal, the Deputy Director of Utilities - Engineering will make a final ruling on the variance request. The applicant can request an in-person meeting with the Deputy Director as part of the appeal process. At his or her sole discretion, the appeal request may be presented to the Utility Board for a final decision. The decision of the Deputy Director (or Utility Board when appropriate) will be provided directly to the applicant and to the appropriate EWSU Capital Program Manager.

		<h2 style="margin: 0;">Variance Request Form</h2>	
		Created: January 2015 Revised:	
Applicant:			
Project Name:			
Work Order/DVS Number:			
Date:			
I hereby certify that the data and information provided is accurate and correct to the best of my knowledge (affix PE seal and sign)			
Handbook Chapter			
Handbook Section			
Description of infeasible and/or unreasonably burdensome design standard			
Description of alternative and how it will achieve same objective as standard. Attach drawings, specification sheets, manufacturer cut sheets, etc.			
Estimate of life cycle costs, including construction cost, for complying with the standard and for the proposed variance.			
Does the alternative comply with all other EWSU, local, state, and federal requirements? Explain.			
Reviewer:			
Decision:			
Supporting Comments (optional):			

Figure 1-1: Variance Request Form

SECTION 2: Utility Customers

2.1 General Rules of Service

2.1.1 Authority and Privileges of Utility Employees –

The General Manager, Executive Director, supervisor, or other employee of the Utility may act as inspector from time to time. They may enter at all reasonable hours into any house, business, or premises supplied water by the Utility to examine all attachments, appurtenances, fixtures, etc., take meter readings, repair or remove meters, or make other changes as necessary. The Consumer may request proper identification of the employees. After identification has been satisfied, the Utility reserves the right to discontinue water service if access is denied.

2.1.2 Quality and Protection of Water

Water furnished by the Utility for human consumption or for domestic use shall be of such quality as to meet the requirement of the I.D.E.M.

2.1.3 Adequate Service Requirements

The Utility shall at all times endeavor to maintain and provide uniform pressure and flow volumes, however, variations are to be expected.

2.1.4 Continuous Service

Every effort to give continuous and uninterrupted service will be made by the Utility, but nothing in these rules shall be construed as a guarantee or agreement to give such continuous and uninterrupted service.

2.1.5 Utility Not Liable for Accidents, Breaks, etc.

In case of accidents, breakdowns, shortage of water supply, or any causes beyond control of the Utility, or in case of making repairs, connections, renewals, or replacements, the Utility reserves the right, when reasonably necessary, to shut off the water supply from anyone or any number of premises without notice, and shall not in any manner be held responsible or liable for damages resulting from such discontinuance of service. The Utility will endeavor to give notice where such as practicable, but the Utility will not be required to give such notice when it is necessary to discontinue water service in order to make repairs, renewals, etc.

The Utility will not be held liable in any way for damages done to plumbing, fixtures, or pipes located beyond the Stop Valve by reason of freezing, bursting, etc. Consumers are advised to shut off immediately the water supply at the Consumer's Stop and Waste Valve in case the premises are vacated or in the event any plumbing fixtures should burst or break.

2.1.6 Shut Off Not Cause for Rebate or Refund

The temporary shutting off of the water supply and the temporary discontinuance of service to any premise shall not entitle the Consumer to any abatement or reduction of Utility charges.

2.1.7 Street and Other Valves

The Utility reserves the exclusive right to open and close all valves on street mains, hydrants, etc. on large service connections.

2.1.8 Cisterns

Those requiring cisterns to be filled with water should contact a private water supplier. It will be the Consumer's responsibility to have the water supplied and cistern approved by the state and/or local board(s) of health. No water from a cistern or well may be connected to service piping that is connected to a Utility water main.

2.1.9 Secondary or Other Sources of Water Supply

Cross Connection with a well, pond, lake, stream or other water source not of the Utility is contrary to local, state and national health regulations and is prohibited. The discovery of any such Cross Connection will be sufficient cause for Utility to shut off water supply without notice, and the state and national regulatory agencies will be notified. The private water supply shall be totally disconnected once the Utility water supply is in service.

2.1.10 Water Retirement/Reinstatement

If a building connected to a public waterline (a) has been demolished and has not been rebuilt and reconnected to the public waterline for a period in excess of sixty (60) months; or (b) has not utilized water from the public water main for a period in excess of one hundred twenty (120) months, the property will no longer be permitted to utilize the existing water service line serving the property. In either such event, to reinstate water service, the property owner will be required to install a new service line from the public water line and pay a tap fee. A credit will not be allowed for any prior tap fee. This policy has been implemented to protect the quality of water service provided to the property.

2.2 Meter Service Application

2.2.1 General

The following conditions must be met in order for water services to be requested:

- The water main must be activated
- The water main must be accepted for maintenance or an approved letter of credit is on file
- The public water main must extend across the full frontage of the tax parcel property to be served. Properties without frontage on a road may have a service in an ingress/egress and private utility easement that provides access to the property in a manner that is acceptable to the Utility.
- The water main to which the water service will be connected, must be a public water main that has been accepted into the EWSU inventory for maintenance or be activated with a letter of credit on file.
- The water main must be located within adequate road right-of-way or easement.

2.2.2 ¾" and 1" Service

There will be two options for obtaining ¾" or 1" taps for ¾", 5/8", or 1" meters.

A developer may have services installed within his own subdivision or the services may be installed by requesting a new service, in which case a contractor under contract to Evansville Water and Sewer Utility shall install the service.

At the time of application for water extension, the developer shall declare whether the services will be installed by the developer or installed as they are needed by the Evansville Water and Sewer Utility contractor. All commercial services shall be installed by the developer.

See summary of water rates and charges for the current cost of installing the ¾" and 1" services.

The fees are based on actual contracted price for labor and material to tap the main, install saddle, install service line to property, and install stop box at the property line plus the cost of the meter.

All applicants for new services shall be charged this fee for a new tap.

Developers who are installing their own services shall be charged this fee for each lot in the subdivision, then shall be credited the amount of labor and materials, leaving the charge for the meter only. The fee shall be paid for each lot at the time of application.

Developers shall be supplied with schematic drawings of the service and meter installation and a list of approved vendors for purchasing meter lid and collar, setter, and meter pit.

The cost for a ¾" split service is shown in the summary of water rates and charges.

Refer to Standard Detail DW-20 Service Installations for requirements for small service installation. Service installations for services of ¾" and 1" in diameter shall meet the following requirements:

- Water services shall extend from the main in a perpendicular fashion to the property.
- Deed documentation will control location of service.
- Applicant shall provide a site plan showing proposed water services at time of application.
- New services shall be installed by applicant.
- Service installation shall be inspected by EWSU personnel. Scheduling of inspection shall be coordinated at least 48 hours in advance.
- Road cut permits may be required by other jurisdictions.
- Tap fees will be charged per current schedule of rates and charges.
- All fees are required at time of application.
- The approved material specification document lists appropriate meter lid, collar, setter, and meter pit to use.
- A list of vendors selling approved materials for purchase of will be provided.
- All applicants must provide a completed asbuilt drawing to the Utility before a meter can be provided to the applicant for water service.
- Meters can be picked up at 1931 Allens Lane with receipt, plumbers permit and sanitary sewer inspection documentation when applicable.

2.2.3 2" and Larger Service Application

See Section 3.3.3

2.2.4 Split Service Request for 1" and Smaller Services -

- Remit the fee shown in the summary of water rates and charges. This fee is payable to The Evansville Water and Sewer Utility located in Room 104 of the Civic Center Complex at 1 NW Martin Luther King Jr. Blvd.
- Once all applicable fees have been remitted, the meter can be picked up from the Meter Department at 1931 Allen Lane by a licensed plumber.
- The applicant is responsible for hiring a licensed plumber to complete the installation of the split service.
- The applicant is responsible for all materials needed to construct the meter pit according to the detail specifications list on the ewsu.com website with the exception of the meter, which is provided by the Utility.
- Only one split service is allowed per service connection to the main.

2.2.5 Temporary Metered Service

Temporary Fire Hydrant Meters shall be issued only to companies for construction sites, swimming pools, street washing, sewer flushing etc., to provide a NON-POTABLE source of water. Potable water service requires permanent installation. NO Temporary Fire Hydrant Meter shall be issued to private consumers.

2.2.5.1 Deposit & Temporary Fire Hydrant Meter Permit

A deposit must be made as shown in **SUMMARY OF WATER RATES and CHARGES**.

- Money Orders are accepted
- Checks are accepted
- Cash is accepted only in our Civic Center Office
- Credit cards may be used for accounts where the same customer is re-installed and they have been billed previously.
- NO Purchase Orders

Temporary Fire Hydrant Meters may be picked up at the Meter Department located at 1931 Allen Lane, Evansville IN. Deposit must be paid, and application completed prior to meter pick-up.

A Temporary Fire Hydrant Meter Permit must be completed.

- The "Permit" is issued with each Temporary Fire Hydrant Meter
- The "Permit" must be renewed annually.

2.2.5.2 The Temporary Fire Hydrant Meter

After the deposit is made the Temporary Fire Hydrant Meter can be picked up from the Meter Department at the Allen Lane facility.

EWSU will supply

- Meter with Valve, hydrant coupling and 2" x 2 ½" brass hose adapter
- Wrench

Customer must supply (if needed):

- Hoses
- Couplings
- Compliant backflow assembly (either Air gap or RPZ)
- Any other materials to adapt Temporary Fire Hydrant Meter.

2.2.5.3 Temporary Fire Hydrant Meter readings

The customer is responsible for bringing the Temporary Hydrant Meter in every month between the 1st and 15th to be read. The reading will be taken by a Meter Department Supervisor at the Allen Lane facility.

Failure to have the Temporary Fire Hydrant Meter read each month will result in forfeiture of deposit, and possible delay or denial in obtaining future Temporary Fire Hydrant Meters. Fees will be incurred for failure to have the meter read.

2.2.5.4 Basic Instructions for Use of Temporary Fire Hydrant Meters

- When using a Fire Hydrant, turn Fire Hydrant on all the way; adjust flow with valve on meter.
- Use only the Wrench provided by EWSU, any other wrench may damage the stem and render the Fire Hydrant out of service.
- If a part is damaged on either the Fire Hydrant or Temporary Fire Hydrant Meter, the EWSU may charge you with the cost to have the part(s) repaired or replaced.
- Anyone caught using a Fire Hydrant without a Temporary Fire Hydrant Meter, will FORFEIT THE DEPOSIT, and be required to make another deposit in order to keep the Temporary Fire Hydrant Meter. If this happens a second time, the DEPOSIT WILL BE FORFEITED, all Temporary Fire Hydrant Meter privileges will be suspended for a period of 12 months, and legal action may be taken.

No Temporary Fire Hydrant Meter shall be used during freezing weather. Temporary Fire Hydrant Meters should not be used from November 1st – March 31st, unless warranted by prevailing weather conditions.

2.2.5.5 When Project is Complete:

- Return the Temporary Fire Hydrant Meter to the Meter Department, located at 1931 Allen Lane.
- The Temporary Fire Hydrant Meter must be in the same condition as when assigned or the cost of repairs or missing parts will be deducted from the deposit.
- The Hydrant Wrench must be returned.
- If the Temporary Fire Hydrant Meter is returned before the 20th of the month, the deposit will be returned, less charges and unpaid usage fees on or about the 2nd Friday of the next month. (Example: Turn the meter in Jan. 18, deposit returned in Feb.)
- If the Temporary Fire Hydrant Meter is returned after the 20th of the month, the deposit will be returned, less charges and unpaid usage fees on or about the 2nd Friday of the second month. (Example: Turn the meter in Jan. 25, Deposit returned in March)

2.3 Meter Readings and Billings

2.3.1 Reading of Meters

Meters will be read monthly (during the cycle period). If upon reading, the meter is found in good order and has been so during the time since the last previous reading, bills will be rendered in accordance therewith, but the Utility reserves the right, at its option, to read any meter or meters at more frequent intervals. If meter is out of order and/or fails to register, the Consumer will be charged during such failure at the average monthly consumption as shown by the meter when it was in good order. For convenience in making calculations for water supply, estimated readings will be rounded to the nearest thousand gallons below averaged numbers.

2.3.2 Separate Bills for Each Meter

Except at the option of the Utility, readings of two (2) or more meters serving a single consumer will not be combined for billing. A separate bill will be calculated for the service taken by the Consumer through each meter.

2.3.3 Meter Reading Conclusive

The quantity of water recorded by the meter shall be conclusive on both the Consumer and the Utility, except when the meter has been found to be defective or has ceased to register accurately.

2.3.4 Estimated Readings

The Utility will make every reasonable effort to obtain actual meter readings on a monthly basis. However, the reading may be estimated if:

- Inclement weather (rain, snow, ice, etc.) hampers the reading;
- The meter is covered by debris, plant growth, parked vehicles, etc.;
- The meter pit is filled with water or ice;
- No one is on the premises to let the meter reader in to make the reading;

Circumstances beyond the control of the Utility cause excessive delays for the meter readers.

2.3.5 Customer Notice

On certain occasions, the Meter Technicians may leave a door hanger at, or send a letter to the residence informing the occupants of conditions that need to be corrected in order to prevent damage to the meter and assure the meter is accessible for reading. If the customer fails to comply with the requested corrective actions, the customer is subject to service disconnection and any charges that result thereof.

2.3.6 Payment of Bill

All meters shall be read monthly, if possible. If it is necessary to estimate the reading, this will be done pursuant to a billing procedure approved by the Utility Regulatory Agency. Bills shall be rendered monthly per cycle period. Bills will be due and payable within seventeen (17) days following the billing date (shown on the bill).

Note: Billing date will be date marked on bill; and bill will be mailed on this date. If the net bill is not paid within the seventeen (17) days, the bill shall become delinquent and a gross amount which includes late payment charges shall become effective.

If the amount due is not received by the specified shut-off date, the service will be discontinued without further notice. Relief from this procedure can be granted only by the General Manager, Assistant Director, or the Utility Board.

2.4 DISCONNECTION AND RECONNECTION OF SERVICE

2.4.1 Discontinuance of Service by Utility

All water supply service shall be subject to cancellation at the option of the Utility, and service thereunder may be discontinued for any of the following acts or violations of rules:

- For refusal or neglect to pay bills promptly for service rendered. (See Payment of Bills, above).
- For interference, tampering, or damage to meter, meter seal, meter box or vault installed on any service line, or to the curb cock or stop box, or to any appliance of the Utility which is required for controlling or regulating the water supply.
- Failure to apply for service in case of change in ownership or occupancy.
- When Consumer fails to repair leaks between stop box and meter after receiving notice to make repairs.
- When access to the meter or reading equipment is denied to EWSU authorized employees.
- Furnishing water to other than designated premises, per meter application.
- For defrauding, in any way, the Utility.

Note: - If problems persist after routine notice, the Consumer will be notified by certified mail and given a specific date to have correction made. If corrective measures are not made within the specified time, the Consumer will be subject to prosecution, and/or the service will be disconnected and/or abandoned.

A responsible person must be present in the premises when services are restored to see that all water outlets are closed and observe for leaks to prevent damage from escaping water.

2.4.2 Prohibited Disconnection

The Utility shall postpone the disconnection of service for (10) days if, prior to the disconnect date specified in the disconnect notice, the customer provides the Utility with a medical statement from a licensed physician or public health official which states that disconnection would be a serious and immediate threat to the health or safety of a designated person in the household of the Consumer. The postponement of disconnection shall be continued for one additional ten (10) day period upon the provision of an additional such medical statement.

2.4.3 Consumer's Request for Turn Off or Turn On

All requests of consumer for shutting off or turning on water to their premises should be made through the Utility office. The Utility will not be held liable in any way for damages done to plumbing, fixtures, or pipes located beyond the curb cock by reason of freezing, bursting, etc., after request of turn off has been made. Consumers are especially warned to immediately shut off the water supply at the Consumer's stop and waste valve and drain the plumbing within the building in case the premises are vacated or in case in plumbing fixtures should burst or break.

2.4.4 Restoration of Service Due to Non-Payment

The full amount must be paid plus a reconnect service charge. (See summary of water rates and charges).

Evidence of corrective measures or agreed compensations must be presented in person for restoration of service. When payment or authorization is made Monday through Friday at the Utility Office, service will be restored as soon as possible but at least within one (1) working day.

A responsible person must be present in the premises when service is restored to see that all water outlets are closed and observe for leaks to prevent damage from escaping water. If the consumer cannot be on site when service is restored, a waiver option is available which releases EWSU from liability of damage in the event water leaks as a result. The consumer must turn off the main shut off valve inside the property prior to water service being restored.

When consumer moves, all charges will follow. Moving from one service address to another does not release a consumer from an unpaid charge at a previous address.

An additional deposit may be required from an existing customer who has been mailed disconnect notices for two (2) consecutive months or any three (3) months in the past twelve (12) months, or who has had service disconnected for non-payment of a delinquent bill(s). The requirement shall not exceed one-sixth (1/6) of the Consumer's estimated annual billing. If the required deposit exceeds \$70.00, payment may be permitted over a period not to exceed eight (8) weeks.

2.4.5 Disconnection for Non-Payment of Delinquent Bill

The Utility may require a deposit be paid prior to reconnection of service. The Utility will provide a written receipt at the time the deposit is paid by the Consumer.

2.4.6 Adjustment or Reduction

On which such charges are based, inaccuracies in the registration of the meters, or error on the part of the Utility in making any charge. Claims for such adjustment or reduction must be made, preferably in writing, within fifteen (15) days after the rendition of the bill or question in dispute. When any claim for such adjustment or reduction is made and filed with the Utility, it shall be presumed that the meter from whose reading the claim for such adjustment and reduction arose, was correct at the date six (6) months prior to the filing of such claim for adjustments and reductions. No claimant shall, in any event, be allowed or paid a refund or allowed an adjustment or reduction in excess of six (6) months.

2.4.7 Adjustment for Leaks - (Plumber's Affidavit Required)

EWSU may adjust unusually high bills resulting from leaks underground, in crawl spaces, or under concrete floors. Leaks resulting from vandalism or neglect (toilet leaks, outdoor spigot being left on, etc.) **will not be considered for adjustment.**

The consideration for adjustment may be made to the Consumer for one-half the water used over the average usage from the past 12 months and all the sewer charge for all the water used in excess of the monthly average. For Consumers who have less than 12 months billing history on the account, all months available will be used to calculate the monthly average.

Plumber's Affidavits, requirements and instructions may be obtained in-person or via mail from EWSU Customer Service. An example of the Plumber's Affidavit can be found on the next page.

Any other loss occurring on the Consumer's side **shall not be considered for adjustment**, unless relief is granted on a case by case basis by the Director, Deputy Director, or the Utility Board for extraordinary circumstances beyond the consumer's control.

2.4.8 Number of Repairs Allowed for Adjustments

Only one adjustment per year per meter may be considered. Please contact Customer Service for more information.

2.4.9 Plumber's Affidavit Form

Request form via phone, email or in person.

2.5 Meters

2.5.1 Meters

The Utility reserves the right to have meters installed on all service connections, including services installed for fire protection.

2.5.2 Utility to Furnish Meters

All water meters shall be furnished by the Utility. However, before any meter is furnished, the consumer must complete the necessary application and pay the fixed service charges as provided for in the summary of water rates and charges. The meters so furnished shall be and remain the property of the Utility and subject to the exclusive control and jurisdiction of the Utility.

Note – only authorized Utility employees and licensed plumbers are permitted to install and remove meters.

2.5.3 Meter Installation Plumbing

Shall conform to the meter plumbing specification layout drawing, which can be obtained at the Plumbing Inspector's or Utility office. No consumer shall remove or cause the removal of a meter once it has been installed. Any change in location of a meter desired by the Consumer shall first be submitted to the Utility for approval. The new installation must conform to Utility specifications and pass City plumbing inspection.

2.5.4 Size of Meter Required

The size of meter required for any service shall be governed by the size and characteristics of the premises served or to be served. The Utility reserves the right at all times to determine the size of meter to be installed. Meter size is to be stated at the time application for meter is made. Meters so specified by the Utility will be subject to changes thereafter as conditions of service, the demand for water supply, and other conditions may develop. The Utility reserves the right to increase the size of any meter in any case where the consumption or supply of water may require it, and likewise to a smaller size of meter where the one installed is found to be in excess of the size actually required.

2.5.5 Care of Meters

All meters shall be owned, installed, maintained, tested, repaired, removed, and replaced only by the Utility (or a licensed plumber). The Consumer shall provide a safe physical, visible access to the meter and a dry, clean place protected from freezing and excessive heat. The location must be acceptable to the Utility. The Utility reserves the right to require the property owner to relocate the meter to an acceptable location at the owner's expense.

2.5.6 Meter Repairs, Renewals, and Replacements

Repairs, renewals and replacements of all water meters due to ordinary wear and tear, ordinary effects of age and the elements, or some defect in the meter itself, shall be borne by the Utility.

In case of any damage to a meter, either accidental or willful, the Consumer shall notify the Utility thereof. The Utility will make the necessary repairs required. Willful damage or damage attributed to negligence on the part of the Consumer will be charged to the Consumer.

2.6 Plumbers and Plumbing

2.6.1 License and Permits Must Be Secured

No person shall do any plumbing (whether new work, repairs, remodeling, or alterations) in connection with the Utility system without a license pursuant to and in conformance with the applicable laws and ordinances of the State of Indiana and City of Evansville-Vanderburgh County.

Any individual performing plumbing work as defined herein shall carry on their person proof of licensure and, upon request by Utility or other local official having authority, produce proof of licensure.

Any person performing plumbing work in Vanderburgh County or the City of Evansville must obtain a plumbing permit. Plumbing must be inspected and approved by the Evansville-Vanderburgh County Building

Commissioner's Office. No individual shall procure or attempt to procure permits in their own name or the name of any other person for the benefit of a suspended license or unlicensed individual.

2.6.2 Defective Work

All plumbing, materials and fixtures used in connection with the Utility system shall be in conformance with applicable local and state standards, codes and specifications. If the Utility or any inspector or official having authority finds plumbing, materials or fixtures not in conformance with standards, codes or specifications, the Utility may refuse to turn on the water supply or may discontinue water supply if previously connected.

2.6.2.1 Violations of Rules by Plumbers Will Be Cause for Utility to Request License Suspension

Any licensed plumber who 1) fails to comply with any applicable local, state or federal rules and regulations 2) refuses or neglects to correct deficient work after notice has been given, 3) fails to report work performed or 4) turns on water and leaves it on to any premises without current meter deposit, will be subject to any applicable charges and penalties and reimburse the Utility for any expenses caused by such violations.

2.6.3 Stop Valve and Plumbers

Plumbers who have secured a license in accordance with the applicable state and local laws and ordinances and have executed the necessary and required bond, are permitted to shut off or turn on water under the following conditions:

- No water is to be turned on without a meter being installed.
- Water may be shut off by plumbers at the Stop Valve when leaks occur on the Consumer's side of the Stop Valve for the purpose of making repairs or modifications to the Consumer's piping.

No connections to any Stop Valve or service pipe for the purpose of supplying water to premises shall be made without first making application with the Utility and securing necessary permission.

2.6.4 Stop Valve Not to Be Used by Consumer

The Stop Valve on any service connection is off limits to and shall not be used by the Consumer for turning on or shutting off the water supply except in an emergency situation to prevent property damage. Other than emergency situations outlined above, all turning on or shutting off of the water supply by the Consumer shall be done with a separate valve located on the Consumer's side of the meter. All normal (non-emergency) Turn On or Turn Off of the water supply is to be made by the Utility or licensed plumbers permitted to do so.

2.6.5 Care and Use of Service Box, Valve, Valve Box

No person shall tamper with Stop Valves, meter lids, or appurtenances thereof. Any acts resulting in damage to the Utility property will be subject to charges.

2.6.6 Shutoff Valve or Stop and Waste Valve

A separate valve shall be placed on each service line inside a building or structure for the purpose of shutting off water from the meter on the Consumer's side.

If a building is to be unoccupied, the plumbing should be drained. Consumers dependent on a supply of water taken directly from the service lines and the working hydraulic pressure of the water distribution system of the Utility do so at their own risk. The Utility will not be responsible for any accidents or damages.

2.6.7 Prohibited Use of Electric Wires for Grounding

Wires, metallic connection or other electric grounding on any service pipe, water main or other fixture of the Utility is prohibited.

2.6.8 Lawn Sprinkling Fixtures

All lawn irrigation must be installed with backflow prevention in compliance with current state and local rules and regulations.

2.6.9 Consumers Having Boiler, Hot Water Heating Systems

Boilers and water heating systems connected directly or indirectly with the distribution mains of the Utility must have a check valve in the supply pipe to the heating system and a relief valve at some point between the check valve and heating system.

Consumers are cautioned as to the potential damage to boilers and water heating systems since it is sometimes necessary to shut off the supply of water without notice.

The Utility will not be responsible for accident or damages resulting from the imperfect action or failure of check valves, relief valves or vacuum breakers. Check valves, relief valves, flush valves and vacuum breakers required or recommended by this rule must be provided, installed and maintained by and at the cost of the Consumer. Boilers must be installed in accordance with all applicable local and state rules and regulations.

2.7 Fire Service

2.7.1 Installation of Service Charges

When private fire protection is desired and applied for at the Utility office by any Consumer and assented to by the Utility, the person making application shall pay to the Utility the amount stated in a specially prepared estimate presented by the Utility, per current fees, for each connection desired. Connections for automatic sprinkler service will, unless otherwise stated, include all taps, valves, pipes, etc. to complete such service connection from the water main in the street to property line.

2.7.2 Size and Number of Services

The Utility reserves the right to decide what size service shall be connected. No single connection for sprinkler services shall be made larger than twelve (12) inches in diameter. Only one service will be allowed to any one building or premise unless, in the opinion of the Utility, more than one is absolutely necessary for the protection of the same. Where more than one connection is made for one building or premises, they shall be connected at different points in the distribution system: An approved backflow prevention valve must be installed in each connection to prevent back flow.

2.7.3 Contamination of Water Supply

Any fire protection system supplied with water from the Utility service shall be supplied exclusively with such water. **NO** connection will be allowed to any other system drawing its water supply from another source. The Utility supply could be contaminated by failure to close valves, leaking check valves, etc.

A suitably approved backflow prevention device must be provided by the Consumer.

Note: - No use of antifreeze or any other foreign substance will be permitted.

2.7.4 Inspections

All fire services shall be subject to inspection by the Utility from time to time. The Consumer shall give any information concerning the service that the Utility may require.

2.7.5 The Utility May Install Meter

The Utility reserves the right to install a detector meter for private fire protection. This meter shall remain the property of and under the exclusive control of the Utility. No charge will be made by the Utility for water actually used through the sprinkler system connection in the extinguishing of any fire, but if a fire occurs, the Utility should be immediately notified. Proper adjustment will be made for the same.

2.7.6 Guarantees

The Utility in no manner guarantees to furnish proper quantity of water through the fire protection service, nor does it undertake to guarantee anything relative to such service. It will endeavor to maintain the efficiency of its service under all conditions.

2.7.7 Public Fire Hydrants

All public fire hydrants installed by the Utility shall be used exclusively for fire protection unless a special permit has been granted for other purposes.

2.7.8 Obstruction of and Damage to Fire Hydrants

All public fire hydrants shall at all times be readily accessible. The placement of dirt, rubbish, debris, landscaping or any other material or object over or around any fire hydrant is prohibited and any party found in violation shall, upon notice from the Utility or from the fire department, remove without delay any such obstruction. Any party damaging any public fire hydrant in any way shall bear all costs of repair or replacement of the hydrant. The Utility, upon completion of repairs or replacement resulting from any aforementioned damage, will render a bill for the total amount of damages sustained. Said bill must be paid within thirty (30) days thereafter.

2.7.9 Temporary Permits Issued

No water shall be taken from public fire hydrants for any purpose without first securing a temporary fire hydrant meter and permit from the Utility operations offices located at 1931 Allen Lane, Evansville, Indiana 47720. Said permit will designate the hydrant or hydrants from which water may be used. Where permits have been issued for public hydrant usage, parties opening the fire hydrants must be either an employee of the Utility, fire department or one who is deemed by the Utility as having the proper knowledge of the use and care of fire hydrants. Any person or persons found guilty of using a fire hydrant without having first

secured the necessary permit, unless for emergency, shall be subject to any applicable state and local rates, charges, and penalties.

Note - Any person opening any public fire hydrant for emergency use must remain in the vicinity of the hydrant until a Utility employee or other official having authority arrives.

2.7.10 Temporary Permit Form

Request form via phone, email or in person.

2.8 Consumer and Utility Responsibilities

2.8.1 Consumers Must not Permit Others to Use Water

Applications for water service, when accepted by the Utility, shall cover only the premises applied for at one point of delivery. Consumers are prohibited from selling or giving away water or granting privileges to anyone to use water for any purpose not primarily specified in writing to the Utility.

2.8.2 Change in Ownership

Notice must be given of any change in Consumer, Tenant, or Owner of any premises receiving a supply of water from the Utility. When such a change results in a change of responsibility to the Utility for usage charges incurred, said change shall be submitted to the Utility office; The Utility will require the new Consumer to make application for a water supply service.

In the event any consumer fails to notify the Utility of such a change in occupancy or ownership of premises, such Consumer will be liable to the Utility for all charges accrued for all services at such premises.

2.8.3 Size of service

The Utility, in every instance, reserves the right to designate and prescribe the size of any new service connection, or any renewal or replacement of an old connection. In any case where a size of service other than applied for by the Consumer, or previously existing, is so designated and prescribed by the Utility, the Consumer shall be bound thereby. For ordinary dwellings, the service pipe shall be three-quarter (3/4) inch in diameter with a 5/8" or 3/4" meter. The service pipe can be extended from the stop valve by any plumber who has secured a license as provided by the laws of the State of Indiana and Ordinances of the City of Evansville, Indiana. Necessary and proper permits must have been obtained from the Building Commission by the plumber or property owner.

2.8.4 Consumer to Make All Private Connections

All Consumers making application for metered service shall be responsible for the necessary connections with all fixtures, appliances, etc., in order for all the same to be supplied through the meter(s) installed

2.8.5 Repairs, Renewals, Replacements, and Relocations

All repairs, renewals and replacements of service connections installed by the Utility shall be made by the Utility without charge. On occasion, services must be relocated due to water main relocation or road projects. When this occurs, the Utility shall relocate the service line and update the stop valve and, the meter setter and pit if deemed necessary by the Utility. There shall be no cost to the consumer for this relocation. **The Utility will not be held responsible for faulty plumbing on the customer's side of the stop valve once the meter is**

reconnected to the original plumbing. The Utility or contractor representative of the Utility reserves the right to determine whether a service line shall be renewed. Careful inspection of the existing service line shall be done once the line is exposed during construction.

Should a larger service be desired, the Consumer will pay the difference between the size being abandoned and the size being requested. This provision shall only apply if Utility is in the process of renewing the service at the time of such request. All charges for a larger service must be paid before any enlargement can be made.

Should repairs be necessary from the main to the stop valve through carelessness, negligence, or willful damage thereto on the part of the Consumer or other person(s), repairs for the same shall be made by the Utility and charged to the Consumer or person(s) responsible for the damage.

2.8.6 Stop Valve Not to Be Used By Consumer

The stop valve on any and all service connections shall not, in any way be used by the Consumer for turning on or shutting off the water supply except in an emergency situation to stop property damage. All turning on or shutting off of the water supply by the Consumer shall be done with a separate stop valve located on the Consumer or house side of the service stop valve or the meter. All normal turn on or shut off of the water supply is to be made by the Utility, except in cases where licensed plumbers are permitted to do so.

2.8.7 Retired Service Request

All Consumers making a request to retire a water meter service must fill out an application listed on the EWSU website.

2.8.8 Sanitary Sewer Responsibility

Customers own and are responsible for maintenance of the sanitary sewer lateral connection from the home to the connection at the sewer main line. The EWSU owns and maintains the sewer main located in the street or easement. The customer may voluntarily install a clean-out on their service lateral at the property line. In cases where there is an accessible clean-out at the property line, the EWSU will maintain the lateral connection from that point to its connection with the main. The property owner will continue to own and maintain the lateral from the property line clean-out to the home or building.

2.8.9 Sewer Later Connection Conditions

The following conditions must be met prior to a sanitary sewer connection is requested:

- Testing must be complete
- The sanitary sewer main must be accepted for maintenance or an approved letter of credit is on file

2.9 Complaints

2.9.1 Complaints

All complaints concerning the service of employees of the Utility should be made at the office of the Utility, preferably in writing.

The Utility shall keep a record of all complaints that are in writing or in person received at its office in regard to service, which shall include the name and address of the Consumer, the date, nature of complaint, and the remedy of disposal thereof. The records shall be available for inspection by duly accredited representatives of the Public Service Commission of Indiana, for a minimum of three (3) years.

2.9.2 Rule as Part of Contract

All the foregoing rules and regulations shall constitute a part of the contract with each and every person, firm, corporation, or company that uses water supplied by the Evansville Water & Sewer Utility and every such person, firm, corporation, or company shall be considered as having expressed their consent to be bound thereby, the same as if such rules and regulations were copied and embodied in all contracts and water permits.

The Utility, upon request, shall provide a copy of its fees, rules, and regulations.

In the event any situation arises which is not covered by the foregoing provisions, then a determination must be rendered by the Utility Board.

SECTION 3: Developers

3.1 Introduction

3.1.1 Purpose

The purpose of this Section is to provide guidelines and expectations for the process of:

- Filing applications for water or sewer main extensions, water services of 2 inch diameter and greater, fire protection services, and all commercial water services less than 2 inch in diameter
- Review and approval of applications
- Construction process for main extensions
- Approval and acceptance of the improvements

3.1.2 Applicability

These procedures shall apply to all extensions to drinking water systems and wastewater systems that are currently owned and operated by the Evansville Water and Sewer Utility (EWSU). These procedures shall also apply to all systems that are constructed with the intension of turning over ownership to the EWSU at any future time.

For private drinking water or wastewater systems which are wholly owned, operated and maintained by a private entity, but will connect to the public system, the design and construction standards of the EWSU shall be followed. Examples of private sanitary sewer projects that do not qualify for acceptance are:

- Apartment complex sewer systems
- Mobile home park sewer systems
- Shopping center sewer systems

All requests for new water or sewer main extension, new water service of two inch diameter and greater, new fire protection service, or commercial water service less than two inch in diameter, will require submittal to the EWSU engineering department for review and approval prior to permitting.

3.1.3 Ownership

The EWSU owns, operates, and maintains the drinking water distribution system and the sanitary sewer collection system. The water system includes water transmission and distribution mains, valves, hydrants, and service connections of various sizes, normally within an easement or street right-of-way. The sewer collection system includes gravity mains, pressure mains, pump stations, and valves.

During the construction of a water or sewer main extension, the applicant for extension shall remain the owner of the improvements until such time that a final inspection has been made, all improvements have been deemed by the EWSU to be constructed per the standards of the EWSU, and the project has been formally accepted by the Board of Directors of the Evansville Water and Sewer Utility, per these procedures.

3.1.4 Organization of Water and Sewer Main Extension Procedures

These procedures define the process for application for and construction of water and sanitary sewer main extensions, large water services 2 inch and above, fire protection services, and all commercial water services less than 2 inch in diameter. This section is generally organized as follows:

- Simple Inquiry
- Early Coordination
- Submittal Requirements
- Methods of Generating Review
- Area Planning Commission Sub-division Review
- Area Planning Commission Site Review
- EWSU Preliminary Application
- Initial Review Process
- Formal EWSU Application Process
- Formal EWSU Plan Review Process
- Utility Coordination Process
- Approval Process
- Construction Process
- Post Construction Process
- Fees

3.1.5 Compliance with Other Standards

Compliance with the policies and procedures of the Evansville Water and Sewer Utility does not relieve the applicant of the responsibility for compliance with other applicable regulatory agency requirements including the latest revision of the following:

- American Water Works Association (AWWA) Standards
- Great Lakes - Upper Mississippi River Board of State and Provincial Public Health and Environmental Managers, Recommended Standards for Water Works (Also referred to as Ten States Standards for Water Works)
- Great Lakes - Upper Mississippi River Board of State and Provincial Public Health and Environmental Managers, Recommended Standards for Wastewater Facilities (Also referred to as Ten States Standards for Wastewater Facilities)
- Indiana Department of Environmental Management (IDEM) Regulations

- Indiana Administrative Code (IAC) Title 327 Water Pollution Control Board
- Indiana Administrative Code (IAC) Title 675 Article 16 Plumbing Code
- Indiana Building Code
- City of Evansville Code of Ordinances
- Indiana Fire Code
- Indiana Department of Transportation (INDOT) Standard Specifications, latest edition
- Indiana Manual of Uniform Traffic Control Devices (IMUTCD), latest edition
- Indiana Department of Homeland Security

3.2 General

3.2.1 Engineering Expectations

It is implicitly understood that all applicants have or have secured engineering capabilities that contain a core competency to satisfy EWSU application requirements and expectations. Failure to display this core competency and meet expectations may result in submittals returned to the applicant without full review. Full review will be completed on these applications at a time when a subsequent submittal includes the necessary items required for a full review as detailed in this manual.

3.2.2 Dependency on EWSU for Operation During Project Construction

If the development plan includes dependency on the EWSU to operate existing infrastructure for the installation of the project, coordination between the design engineer and the EWSU operation is required during the design phase to verify existing infrastructure can be operated as needed. Failure to do so during the planning and design will result in the contractor or developer to incur costs associated with the additional materials and schedule delay as a result of lack of coordination and validation.

3.2.3 Types of Applications

There are several types of applications that can be made for service. Following is a list of the various applications for service:

- Sanitary Sewer Main Extension – This application must be made at all times where the existing sanitary sewer system is physically extended to one or more customers
- Water Main Extension – This application must be made at all times where the existing drinking water system is physically extended to one or more customers
- Large Water Service – This application must be made when a new service of two inches or greater in diameter is needed to supply water to a customer. This application also covers services intended for fire protection of a property.
- Small water service – This application for service must be made for all drinking water services requiring a meter of 1 inch or less.

- Sewer Service Installation or Tap – This application must be made for all connections to a sanitary sewer main for service.

3.2.4 Simple Inquiry

Communication with the Evansville Water and Sewer Utility regarding the installation of services covered under this section is with the Utility Engineering Department.

All potential applicants are encouraged to contact the engineering department, either in person or through electronic transfer of information, for water and sewer utility information regarding utility size, location, availability, etc. The engineering staff can also provide information on the application process and expected timelines for securing approvals to begin construction. A simple inquiry is a very informal fact finding meeting.

The purpose of an inquiry is two-fold. The initial contact allows for information sharing between the engineering staff and the applicant. It also serves as a means for the EWSU to recognize geographic areas where there is interest in service. There is no obligation on the potential applicant or the EWSU during an inquiry but the staff may log general information about the inquiry for future reference.

Inquiries are not mandatory but will provide a good opportunity to exchange information very early in planning.

3.2.5 Early Coordination

The Early Coordination submittal and meeting is a formal process between the potential applicant and the EWSU engineering staff for the purpose of exchanging information early in the process. It is the intent of this process to set the stage to allow the project to move forward more efficiently through the application submittal and approval process.

The Early Coordination process is voluntary for all water and sewer main extension projects. The EWSU staff will provide guidance on the process from formal application through construction close-out and acceptance for maintenance. The exchange of information early in the development process can uncover potential challenges that may affect the project budget or schedule. Although the early coordination process is voluntary, it is highly recommended that applicants for main extensions participate in the process. Potential issues that can significantly delay a project can be uncovered during the early coordination meeting and possibly mitigated. This is also the time to review the application process to make sure applicants understand all requirements.

The Early Coordination process is also voluntary for all large water service projects, including services two inches in diameter and greater, and all fire protection services. It is recommended that applicants with large service requirements engage in the Early Coordination process for the purpose of establishing a more efficient flow through the formal application process.

3.2.5.1 Submittal Procedures

Although there is no filing deadline, the Early Coordination submittal should be sent to the EWSU as early in the project development stage as possible. Ideally, the Early Coordination submittal should be presented to the EWSU when the project engineer and/or land surveyor has enough information regarding the project to complete the early coordination checklists and create the exhibit drawing. In order to avoid delays in sub-division projects, the Early Coordination submittal should be submitted to the

EWSU at a minimum of two (2) calendar weeks prior to the Area Planning Commission Subdivision Review Committee meeting scheduled for review of the sub-division project. This provides time for the EWSU to provide a thorough review of plans prior to the formal application process. For all non-subdivision projects, response to the Early Coordination submittal will be given to the Developer and Engineer within two (2) calendar weeks of the date that the EWSU receives the complete Early Coordination submittal.

The applicant must use the appropriate Early Coordination Checklist form for either water or sanitary sewer and submit a basic exhibit drawing of the proposed system. The exhibit drawing must, at a minimum, contain the following information:

- The approximate boundaries of the proposed development
- The desired point of connection the EWSU existing system
- Intended land use of the proposed development
- For sanitary sewer extensions, the estimated flow to be generated by the development, based upon known data
- For potable water main extensions, the estimated daily demand for the development, based upon known data
- For service connections, the desired point of connection and intended use of the property
- Contour lines sufficient enough to identify high and low points within the development

3.2.5.2 Service Connections

The Early Coordination process is also optionally available for service connections where extensions of public water or sewer mains are not required. If a Developer/Owner desires to verify the ability to connect to the existing water and/or sanitary sewer system, the same checklists and submittal requirements for major and minor projects shall be required. Within two (2) calendar weeks from the submittal date, a written response will be provided to the Developer/Owner stating the availability of the requested service(s).

This statement of availability of service does not relieve the applicant of the responsibility to file the formal application for service. The statement of availability of service does not provide a formal guarantee of system capacity. The approval of the formal application for service will establish final approval for the connection.

3.2.5.3 Limitations and/or Disclaimers Regarding Early Coordination Process

- Approval to move forward on any project at the Early Coordination stage shall not be considered to be approval for construction. No construction of any kind related to the Early Coordination process may begin until the Utility Board has approved the submitted plans for construction.
- Approval to move forward on any project at the Early Coordination stage shall not be considered a guarantee of capacity to furnish the requested drinking water demand or

sanitary sewer system capacity. Water system demand and sanitary sewer system capacity is not reserved until the Utility Board approves the project for construction.

3.2.6 Methods of Generating Formal Review by EWSU

There are three avenues for initiating the formal project design submittal through the EWSU for review, comment, and approval. They are the following:

- Submittal of a proposed sub-division through the Evansville Vanderburgh County Area Planning Commission (APC)
- Submittal of a proposed new or improvement of an existing commercial or industrial site through the Evansville Vanderburgh County Area Planning Commission
- Submittal of plans directly to the EWSU as a preliminary application for extensions of services or new service in instances where not required to submit to the APC

3.2.6.1 Subdivision Submittals

When an application for a sub-division is submitted to the APC, those sub-division plans are forwarded to the EWSU for review and comment. A sub-division review committee will hold a regularly scheduled meeting for review of the submittal. The EWSU is represented on the review committee. The EWSU will provide information on if a water or sewer main extension, large water service connection, fire protection service connection, or potential letter of credit will be required. If a formal application is required, the EWSU will also provide information on the process for filing formal applications for approval prior to authorizing construction. If the early coordination meeting has taken place prior to the sub-division submittal to APC, this information will have already been communicated to the applicant. If it is determined that a formal application is not required, after any recommended revisions are made to the plans, the EWSU will send approval of plans to the APC.

3.2.6.2 Commercial or Industrial Site Submittals

In much the same manner as sub-division submittals, each commercial or industrial site development or improvement must be submitted to the APC for review. Those plans are also distributed to the EWSU by the APC for review. A site review committee holds a regularly scheduled meeting to review all submittals. The EWSU is represented on the site review committee for the purpose of assisting the applicant with EWSU issues. The EWSU will provide information on if a water or sewer main extension, large water service connection, fire protection service connection, or potential letter of credit will be required. The EWSU will also provide information on the process for filing formal applications for approval prior to authorizing construction. If the early coordination meeting has taken place prior to the improvement location permit submittal to APC, this information will have already been communicated to the applicant. If it is determined that a formal application is not required, after any recommended revisions are made to the plans, the EWSU will send approval of the plans to the APC.

3.2.6.3 Preliminary Applications

In some cases, a water or sewer main extension, large diameter water service, or fire protection service may be requested when there is no sub-division or commercial/industrial site development required. In these instances, a preliminary application will be required to the EWSU to start the review process. In

these types of instances, it is recommended that an early coordination meeting be performed to help the applicant through the process of making the preliminary application.

3.2.7 Utility Participation

3.2.7.1 Sanitary Sewer Main Extension Participation

In certain situations where a sanitary sewer main extension is proposed in an area which has upstream sewer shed potential for development, the Evansville Water and Sewer Utility shall have the right to modify the proposed main extension plans to increase capacity beyond that which is required to service the property, application, or development, if in the interest of the EWSU. The modifications will generally take the form of requiring larger diameter sewer, deeper construction, or larger capacity pump stations.

In such instances that the EWSU requires modification of the plans to address the increase in capacity, and funding is available, the EWSU shall determine the size of the pipe needed for the project requiring service. The EWSU shall participate in the construction costs associated with the capacity increase, upon approval of the Board of Directors of the Evansville Water and Sewer Utility.

The developer/applicant shall submit a cost estimates to the EWSU Engineering Department that includes the cost of the originally proposed improvements and the increased capacity improvements. Upon mutual agreement on the construction cost increase, the participation amount will be presented to the Board for approval. The participation amount may include a five percent markup of the construction cost difference for the participation for additional engineering effort required to provide the alternate designs and cost estimates. In cases where deeper sewer construction is considered as part of the construction, additional easement width may be required. Costs for additional easement may not be included in the participation amount. The EWSU shall pay the extra cost of the larger pipe at the least incremental difference of all quotes received.

Construction may not commence until the participation amount is approved by the Utility Board and notice is provided to the developer/applicant. The participation approval shall be considered as part of the application approval process.

All amounts of participation shall be paid by the EWSU to the developer/applicant upon final acceptance of the improvements by the EWSU.

3.2.7.2 Water Main Extensions

The participation policy for water main extensions is intended to assist individual residential applicants in getting water service to their property by water main extension.

An example of this is when a homeowner has property that is several hundred feet from the ending point of an existing water main and must extend that water main across their property in order to receive water service and the main extension will cross the frontage of other properties. The applicant shall approach all other property owners along the route of the proposed extension and make the request to those property owners if they will participate in the cost of the main extension. The cost of new customer participation would be the total cost of the main extension divided by the frontage of each participant.

If there are owners that do not want to participate in the cost of the main extension, the EWSU may elect to financially assist the individual applicant to get the water main extension completed. The applicant will

need to submit the total cost of the extension, the property owners that elect to pay their share of the cost, and the standard application information.

The amount of the cost of the project that is not paid by the property owners along the route shall be presented to the Utility Board, through the Deputy Director-Engineering, for approval of financial participation. The Utility participation amount shall not exceed the recoupable front footage amount along the project route that is considered developable by the Utility. The participation amount shall be at the current front footage charging rate structure. Commercial, industrial, and residential developments will not qualify for participation in any water main extension, whether on-site or off-site unless upsizing of the main size is requested by the EWSU.

This participation policy is intended for individual residential applicants for water main extensions. Commercial, Industrial, and Residential developments will not qualify for participation in any water main extensions, whether on-site or off-site.

3.2.8 Utility Coordination

In an effort to define the location of all utilities within the project limits, including water, sewer, electric, gas, cable TV, phone, the EWSU will set a utility coordination meeting. The EWSU will arrange for representatives for all utilities that will serve the project to meet together to review the project submittal. This meeting shall be attended by the Developer/Owner and designated representatives.

The purpose of the meeting will be to establish the preferred locations for all utilities and will provide notice to all utilities of the potential project. This meeting will also provide an opportunity for the Developer/Owner to have all utility representatives in the room together to discuss schedules and any requirements of the Utilities. The ultimate outcome of this meeting is the orderly installation of utilities for the project to avoid location and timing conflicts.

3.2.9 Professional Certification

For all Developer-initiated projects, the design engineer shall be responsible to confirm that all criteria and standards are implemented accurately in the preparation of project documents. For the final design submittal, all plans are to be certified by an Indiana licensed Professional Engineer in accordance with the requirements set forth by the Indiana State Board of Registration for Professional Engineers Statute and Board Rules and the Indiana Code.

Plans shall be certified as follows:

- For potable water projects, lift stations and force main project, a licensed Professional Engineer shall prepare and certify the plans;
- For gravity sanitary sewer projects, either a licensed Professional Engineer or a Professional Surveyor shall prepare and certify the plans;
- For all projects that require the acquisition of easements in favor of the EWSU, a licensed Professional Surveyor shall prepare and certify the documents.

3.2.10 Opinions of Probable Project Cost for Letters of Credit

For subdivision projects, the Evansville Vanderburgh County Area Plan Commission requires that the proposed water and sewer improvements be either accepted for maintenance by the EWSU or secured by Letter of Credit prior to recording the subdivision plat. The amount of the Letter of Credit is based upon the design engineer's Opinion of Probable Cost for the project. Therefore, for subdivision projects, a detailed estimate of the probable cost of construction shall be provided with the Final Design Submittal. The estimate shall reflect the design engineer's best estimate of the probable cost for the Utility to construct the project as described by the drawings and technical specifications. The estimate should be based on the same drawings and specifications provided to the Utility for review. The project cost methods of measurements and individual pay items shall comply with industry standard units. The Utility shall make standard pay items and typical unit pricing available to design engineers as is feasible.

The Engineer's Opinion of Probable Cost shall be stamped and signed by a licensed Professional Engineer. In cases where the estimate only includes items for the construction of a gravity sanitary sewer, a licensed Professional Surveyor may certify the estimate.

3.2.11 Confidentiality

Once an official application submittal has been made to the Utility, no attempt at confidentiality will be made. No drawings or other project information with confidentiality statements will be accepted by the Utility. Once application has been made for any given project, the submitted project information will be shared with the public or media upon request.

3.2.12 Transferability

3.2.12.1 Changes in project Ownership

Plan approval, and the project responsibility thereof, as issued by the EWSU Utility Board may be transferred to another person or entity without submitting a new application or reissuance of said approval if the original Developer notifies the Utility in writing of such a transfer. This written notification shall include an agreement containing the following:

- Full contact information of the new Developer,
- A specific transfer date for project responsibility,
- Acknowledgement that the new Developer is liable for completion of the project from that date on,
- A statement that the new Developer does not intend to alter the approved project plans.

This written notification shall be signed and notarized by both the original and new Developers. The Utility will then have thirty (30) days from receipt of the written notification to inform the original and new Developers of any requirement to modify the approved plans or that a new application needs to be filed.

3.2.12.2 Changes in Project Engineer

The Developer, at his sole discretion, may elect to change design professionals at any time during the project. If the design professional changes after the issuance of plan approval, the new Project Engineer shall notify the Utility in writing informing them of the change and providing the Utility with his or her full contact information.

3.2.12.2.1 Record Drawings

If a Professional Engineer prepares and certifies the original construction documents and a different Professional Engineer prepares and certifies the project Record Drawings, the second engineer may attach a statement restricting his or her professional certification to only the As-Built information.

3.3 Application, Approval, Construction, Close-Out Procedures

3.3.1 Sanitary Sewer Main Extension

3.3.1.1 General

Applications, review, and approvals of sanitary sewer main extension projects will be processed through the Evansville Water and Sewer Utility Engineering office.

All applicants are encouraged to take advantage of the voluntary processes of simple inquiries and/or early coordination meetings as discussed in Sections 3.2.2 and 3.2.3. These meetings are for information exchange prior to the formal application process and provide the opportunity to assist in making the application and approval process more efficient. There is no fee associated with a simple inquiry or an early coordination meeting.

No plans for sanitary sewer main extension shall be considered for approval if such plans include connection to sewers previously installed which have not been previously accepted by the EWSU into its inventory for maintenance.

3.3.1.2 Reliance Upon GIS Mapping

The EWSU GIS mapping is for informational purposes, only. All map information shall be verified by the Applicant's survey and engineering efforts.

Only field validated existing infrastructure shall be shown on the submittal plans. All existing manholes, valves, and associated infrastructure relevant to the application shall be shown on the plan submittals. If infrastructure is shown on the plans, the EWSU review staff will assume that it has been field verified. Any missing infrastructure shall be identified by the Engineer and communicated to the EWSU during the plan development phase.

Any cost associated with adding valves, manholes, etc., that were shown on the plans but that actually do not exist in the field will be a cost solely borne by the Developer to add to the project during construction.

3.3.1.3 Application

The application is normally generated in from three potential sources. They are the following:

- Site Review Committee – A regular meeting established by the Area Planning Commission to review new commercial developments and commercial changes of use.
- Sub-division Review Committee – A regular meeting established by the Area Planning Commission to review commercial, industrial, or residential sub-divisions of property.
- Requests for main extensions that do not require participation in the Site Review or Sub-Division review process.

The application will be created by the EWSU Engineering staff upon submittal of the following minimum information:

- Plans and Plan Submittal Checklist. The checklist shall have all items included in the plan submittal checked off. If the applicant believes that an item included in the checklist is not required, that item shall be marked as N/A. It should be noted that the engineering staff may communicate that any item interpreted by the applicant as N/A may indeed be required. It is the responsibility of the applicant to verify what is to be submitted with the plans. This can easily be accomplished in an early coordination meeting.
- EWSU QC/QA Submittal Checklist. This checklist will be used throughout the entire life of the project to communicate status. Each applicable item in the checklist shall be checked and acknowledged by the applicant. This is to communicate the requirement that these steps need to take place. Any items interpreted as not required for the type of submittal shall be marked N/A.
- Name and contact information for Developer, including name, address, phone number, email address.
- Name and contact information for Engineer, including name, address, phone number, and email address.
- Variance requests. Any requests for variance regarding any policies, design or construction standards of the Utility shall be submitted with the plans. The variance request form shall be submitted with all documentation required to make a comprehensive review of the variance request.
- IDEM Permit Application – This is not required to initiate a project review but may be submitted with the initial submittal package. This can be delayed until later in the review process but the project cannot be released for construction until an IDEM construction permit is provided to the EWSU.
- IDEM capacity verification document. The IDEM construction permit application requires that the Utility certify that there is available capacity in the existing sanitary sewer system to accept the sewer flow from the applicant's project. This form is part of the IDEM construction permit and as such is not required to initiate an application, however the project cannot be released for construction until an IDEM construction permit is issued and provided to the Utility.

3.3.1.4 Review Process

Upon receipt of the required information to make a formal application for sewer main extension, the Engineering staff will prepare the application and begin the plan review period.

The plan submittal will be reviewed for compliance to the EWSU design policies and agreement with the items in the plan submittal checklist. In addition to general plan review, the reviewer will initiate verification of available system capacity, review adequacy of easements, review draft IDEM permit application, and determine if a letter of credit will be required for the project. The reviewer will make note of any deficiencies in the submittal. Comments on the review shall be forwarded to the applicant, engineer, and developer. The preferred method of communication is by email.

The reviewer may also request a capacity increase revision to the project for potential financial participation by the Utility. Refer to section 3.2.5 for more detail.

It is the goal of the EWSU to provide a response to any submittal within ten (10) working days.

The review process may include revisions and re-reviews and comments. The second review should be for the purpose of making sure that all comments from the first review have been addressed. If it is determined that the review comments have not been satisfactorily addressed, a face to face meeting will be requested by the EWSU staff. The engineer, applicant and developer will be expected to attend to make sure that all parties are aware of outstanding issues.

If the Engineer has delayed submission of the plans to IDEM to make sure all comments by the EWSU have been addressed, the plans should be forwarded to IDEM. If revisions to the plans have been made after the submittal of plans to IDEM, those revised plans shall be forwarded to IDEM. Documentation that any revised plans have been submitted to IDEM shall be provided to the EWSU staff. If IDEM requires revisions to the submitted plans, the revised plans shall be provided to the EWSU staff.

3.3.1.5 Utility Board Approval

Upon review and approval of the application and verification that all requirements have been met, the Engineering Staff shall forward the application to the Utility Board for formal approval at a regularly scheduled meeting of the Board.

The Board will also take up approval of any requests for financial participation in the project at this time.

Upon approval of the project by the Utility Board, notification will be sent to the applicant that formal approval has been granted. In no instance can construction commence prior to approval of the application by the Utility Board.

3.3.1.6 Construction

Prior to construction, the following information must be provided to the utility Engineering staff:

- A letter of credit cost estimate for the value of the construction of the sewer main extension allows the developer to record a plat and start construction. In lieu of a letter of credit, all improvements must be completed and accepted prior to recording of the plat. If a letter of credit will be required for the project, an estimate of cost for the project shall be submitted to the EWSU Engineering staff for review. The staff will review the letter of credit for

completeness and to make sure that unit costs are in line with current construction values. Uniform unit prices for construction will be maintained by the Area Planning Commission and those prices shall be used in the cost estimate. Upon approval of the letter of credit amount, the Utility Engineering staff will forward the letter of credit information to the Area Planning Commission.

- All fees must be paid
- An approved IDEM construction permit
- Notification of contractor name, address, phone number, and email contact information provided to the Engineering staff. The Contractor must be on the Evansville Water and Sewer Utility approved contractor list. This list will be made available to the applicant and developer
- A minimum of forty-eight (48) hour notice that construction is to commence.

The Engineering staff will, upon review of the required information, notify the developer, engineer, and contractor that construction can commence.

The Utility will make arrangements to provide oversight over the construction activities to protect the interest of the utility. It is the responsibility of the developer and contractor to make sure that the construction activities conform to the approved plans, requirements of the IDEM construction permit, and the language of all applicable easements. A set of approved drawings shall be maintained at the construction site. The inspector may require the drawings to be produced during an inspection.

3.3.1.7 Testing

Required testing for all sanitary sewer main extensions is detailed in the construction standards of this manual. The required testing for any sanitary sewer main extension is as follows:

- Air testing for system leakage
- Mandrel testing for deflection
- Vacuum testing for all manholes
- Hydrostatic testing for all force mains
- Pump station testing, when pumping is included in the project

A minimum of forty-eight (48) hour notice shall be provided to the EWSU Engineering staff prior to any testing. The staff will make arrangements to witness all testing for the purpose of verifying compliance.

Testing procedures are detailed in the construction section of this manual and shall be strictly followed. All testing results shall be forwarded to the EWSU engineering department.

3.3.1.8 Acceptance Procedure

Upon completion of the construction activities, the developer/applicant, engineer, or contractor may make a formal request for final inspection. Prior to final inspection the following items must be complete:

- As-Built drawings detailing the plan and profile, as constructed
- GIS information (coordinates)
- All testing complete
- Acceptance guarantee letter – guaranteeing the work for a period of one year

The EWSU will arrange for a final inspection of the extension project. The developer, engineer, and contractor are all welcome to attend the final inspection walk-through. The inspector will develop a punch list of all items that require further work to bring the project into compliance with the plans and construction standards of the EWSU.

Upon completion of the work identified in the punch list, the developer, engineer, or contractor shall request a final inspection. It is expected that the final inspection will be for the purpose of inspecting the items on the punch list that have been completed. If it is determined that there are items on the punch list that have not been completed, without proper documentation as to why, a formal face to face meeting will be required. The meeting shall be attended by the developer, contractor, and engineer.

After all work is in compliance with the approved plans, the terms of the IDEM construction permit, and the acceptance guarantee letter has been received, the Utility Engineering staff will send the project to the Utility Board for acceptance into the sanitary sewer inventory of the Utility.

The Board will send notification to the applicant that the project has been accepted and the one year warranty period will commence. The Engineering staff will notify the Area Planning Commission that the letter of credit can be released.

Upon acceptance of the project, any payments by the Utility for participation shall be released to the developer.

3.3.1.9 Warranty Period

The project is to be warranted by the applicant for a period of one year from the date of acceptance of the main extension.

During the warranty period, the Utility may make periodic inspections of the project. If any deficiencies due to construction are noted, the developer will be contacted by the Utility. A notice of warranty deficiency will be issued. The developer shall have 30 days to remedy the issue or provide a schedule to remedy. If the warranty is not honored, sewer taps may be halted in the development or additional certificates of occupancy may be withheld.

3.3.2 Water Main Extension

3.3.2.1 General

Applications, review, and approvals of water main extension projects will be processed through the Evansville Water and Sewer Utility Engineering office.

All applicants are encouraged to take advantage of the voluntary processes of simple inquiries and/or early coordination meetings as discussed in Sections 3.2.2 and 3.2.3. These meetings are for information exchange prior to the formal application process and provide the opportunity to assist in making the

application and approval process more efficient. There is no fee associated with a simple inquiry or an early coordination meeting.

No plans for water main extension shall be considered for approval if such plans include connection to water mains that have not been previously accepted by the EWSU into its maintenance inventory and are not considered public water mains.

3.3.2.2 Reliance Upon GIS Mapping

The EWSU GIS mapping is for informational purposes, only. All map information shall be verified by the Applicant's survey and engineering efforts.

Only field validated existing infrastructure shall be shown on the submittal plans. All existing manholes, valves, and associated infrastructure relevant to the application shall be shown on the plan submittals. If infrastructure is shown on the plans, the EWSU review staff will assume that it has been field verified. Any missing infrastructure shall be identified by the Engineer and communicated to the EWSU during the plan development phase.

Any cost associated with adding valves, manholes, etc., that were shown on the plans but that actually do not exist in the field will be a cost solely borne by the Developer to add to the project during construction.

3.3.2.3 Application

The application is normally generated in from three potential sources. They are the following:

- Site Review Committee – A regular meeting established by the Area Planning Commission to review new commercial developments and commercial changes of use.
- Sub-division Review Committee – A regular meeting established by the Area Planning Commission to review commercial, industrial, or residential sub-divisions of property.
- Requests for main extensions that do not require participation in the Site Review or Sub-Division review process.

The application will be created by the EWSU Engineering staff upon submittal of the following minimum information:

- Plans and Plan Submittal Checklist. The checklist shall have all items included in the plan submittal checked off. If the applicant believes that an item included in the checklist is not required, that item shall be marked as N/A. It should be noted that the engineering staff may communicate that any item interpreted by the applicant as N/A may indeed be required. It is the responsibility of the applicant to verify what is to be submitted with the plans. This can easily be accomplished in an early coordination meeting.
- EWSU QC/QA Submittal Checklist. This checklist will be used throughout the entire life of the project to communicate status. Each applicable item in the checklist shall be checked and acknowledged by the applicant. This is to communicate the requirement that these steps need to take place. Any items interpreted as not required for the type of submittal shall be marked N/A.

- Name and contact information for Developer, including name, address, phone number, email address.
- Name and contact information for Engineer, including name, address, phone number, and email address.
- Variance requests. Any requests for variance regarding any policies, design or construction standards of the Utility shall be submitted with the plans. The variance request form shall be submitted with all documentation required to make a comprehensive review of the variance request.
- Notice of Intent (NOI) Form – This form is required with the application and shall be completed in its entirety. Applicant shall be required to schedule, perform, and report all static and residual pressure tests. The applicant is required to notify the EWSU Engineering office a minimum of 48 hours in advance of any test.
- Indication of whether water services will be utility installed or developer installed

3.3.2.4 Review Process

Upon receipt of the required information to make a formal application for water main extension, the Engineering staff will create the application and begin the plan review period.

The plan submittal will be reviewed for compliance to the EWSU design policies and agreement with the items in the plan submittal checklist. In addition to general plan review, the reviewer will review adequacy of easements, review NOI, and determine if a letter of credit will be required for the project. The reviewer will make note of any deficiencies in the submittal. Comments on the review shall be forwarded to the applicant, owner, engineer, and developer. The preferred method of communication is by email.

If the EWSU determines that the applicant's project is creating a water quality issue for their development, the EWSU reserves the right to require the addition of a privately maintained auto flush device on a privately maintained dead end.

The reviewer may also request a capacity increase revision to the project for potential financial participation by the Utility. Refer to section 3.2.5 for more detail.

It is the goal of the EWSU to provide a response to any submittal within ten (10) working days.

The review process may include revisions and re-reviews and comments. The second review should be for the purpose of making sure that all comments from the first review have been addressed. If it is determined that the review comments have not been satisfactorily addressed, a face to face meeting will be requested by the EWSU staff. The engineer, applicant and developer will be expected to attend to make sure that all parties are aware of outstanding issues.

If the originally submitted plans are revised for any reason, the revised plans shall be submitted to the EWSU engineering staff for review. Examples of revisions are those required by other review agencies.

3.3.2.5 Plan Approval

Upon review and approval of the application and verification that all requirements have been met, the Engineering Staff will issue an approval of plans to the applicant. The EWSU engineering staff will forward a set of stamped approved drawings to the applicant. These drawings must be maintained at the site during construction.

3.3.2.6 Construction

Prior to construction, the following information must be provided to the utility Engineering staff:

- A letter of credit cost estimate for the value of the construction of the water main extension allows the developer to record a plat and start construction. In lieu of a letter of credit, all improvements must be completed and accepted prior to recording of the plat. If a letter of credit will be required for the project, an estimate of cost for the project shall be submitted to the EWSU Engineering staff for review. The staff will review the letter of credit for completeness and to make sure that unit costs are in line with current construction values. Uniform unit prices for construction will be maintained by the Area Planning Commission and those prices shall be used in the cost estimate. Upon approval of the letter of credit amount, the Utility Engineering staff will forward the letter of credit information to the Area Planning Commission.
- All fees must be paid
- Notification of contractor name, address, phone number, and email contact information provided to the Engineering staff. The Contractor must be on the Evansville Water and Sewer Utility approved contractor list. This list will be made available to the applicant and developer
- A minimum of forty-eight (48) hour notice that construction is to commence.

The Engineering staff will, upon review of the required information, notify the developer, engineer, and contractor that construction can commence.

The Utility will make arrangements to provide oversight over the construction activities to protect the interest of the utility. It is the responsibility of the developer and contractor to make sure that the construction activities conform to the approved plans, requirements of the EWSU construction standards, and the language of all applicable easements. A set of stamped approved drawings shall be maintained at the construction site. The inspector may require the drawings to be produced during an inspection.

3.3.2.7 Testing

Required testing for all water main extensions is detailed in the construction standards of this manual. The required testing for any water main extension is as follows:

- Hydrostatic testing for system leakage
- Disinfection

For disinfection, a chlorination plan must be submitted to the EWSU engineering staff prior to requesting disinfection. The chlorination plan shall provide detail on location of chlorine injection point(s) and

sampling point(s). This plan will be used by the EWSU staff to disinfect the main extension prior to activation. Upon acceptable sampling results from bacteriological testing, the EWSU will issue a notice of activation. The developer, engineer, owner, and contractor should be aware that changes in the number of blow-off points from the approved plan may change the fees required to continue through the project.

A minimum of forty-eight (48) hour notice shall be provided to the EWSU Engineering staff prior to any testing. The staff will make arrangements to witness all testing for the purpose of verifying compliance.

Testing procedures are detailed in the construction section of this manual and shall be strictly followed. All testing results shall be forwarded to the EWSU engineering department.

3.3.2.8 Acceptance Procedure

Upon completion of the construction activities, the developer/applicant, engineer, or contractor may make a formal request for final inspection. Prior to final inspection the following items must be complete:

- As-Built drawings detailing the plan and profile, as constructed
- GIS information (coordinates)
- All testing and disinfection
- Acceptance guarantee letter – guaranteeing the work for a period of one year

The EWSU will arrange for a final inspection of the extension project. The contractor is required to attend the inspection. The developer, engineer, and owner are all welcome to attend the final inspection walk-through. The inspector will develop a punch list of all items that require further work to bring the project into compliance with the plans and construction standards of the EWSU.

Upon completion of the work identified in the punch list, the developer, engineer, or contractor shall request a final inspection. It is expected that the final inspection will be for the purpose of inspecting the items on the punch list that have been completed. If it is determined that there are items on the punch list that have not been completed, without proper documentation as to why, a formal face to face meeting will be required. The meeting shall be attended by the developer, contractor, and engineer.

After all work is in compliance with the stamped approved plans, the water main extension has passed disinfection, and the acceptance guarantee letter has been received, the Utility Engineering staff will send the project to the Utility Board for acceptance into the water main inventory of the Utility.

The Board will send notification to the applicant that the project has been accepted and the one year warranty period will commence. The Engineering staff will notify the Area Planning Commission that the letter of credit can be released.

Upon acceptance of the project, any payments by the Utility for participation shall be released to the developer.

3.3.2.9 Warranty Period

The project is to be warranted by the applicant for a period of one year from the date of acceptance of the main extension.

During the warranty period, the Utility may make periodic inspections of the project. If any deficiencies due to construction are noted, the developer will be contacted by the Utility. A notice of warranty deficiency will be issued. The developer shall have 30 days to remedy the issue or provide a schedule to remedy. If the warranty is not honored, water meter installations may be halted in the development or additional certificates of occupancy may be withheld.

3.3.3 Large Water Services (2 Inch and Larger) and All Commercial Services

3.3.3.1 General

Applications, review, and approvals of large diameter water services, two inch and above will be processed through the Evansville Water and Sewer Utility Engineering office. All commercial and industrial water services less than two inch in diameter will also be processed through the EWSU engineering office.

All applicants are encouraged to take advantage of the voluntary processes of simple inquiries and/or early coordination meetings as discussed in Section 3.2.3. These meetings are for information exchange prior to the formal application process and provide the opportunity to assist in making the application and approval process more efficient. There is no fee associated with a simple inquiry or an early coordination meeting.

The following criteria must be met prior to allowing connection to the public water system:

- The water main to which the water service will be connected must be a public water main that has been accepted into the EWSU inventory for maintenance.
- The water main must extend across the full width of the property being served
- The water main must be located within adequate easement or right-of-way
- All fees, including front footage fees must be paid

3.3.3.2 Application

The application is normally generated in from three potential sources. They are the following:

- Site Review Committee – A regular meeting established by the Area Planning Commission to review new commercial developments and commercial changes of use.
- Requests for services that do not require participation in the Site Review or Sub-Division review process.

The application will be created by the EWSU Engineering staff upon submittal of the following minimum information:

- Plans and Plan Submittal Checklist. The checklist shall have all items included in the plan submittal checked off. If the applicant believes that an item included in the checklist is not required, that item shall be marked as N/A. It should be noted that the engineering staff may communicate that any item interpreted by the applicant as N/A may indeed be required. It is the responsibility of the applicant to verify what is to be submitted with the plans. This can easily be accomplished in an early coordination meeting.

- EWSU QC/QA Submittal Checklist. This checklist will be used throughout the entire life of the project to communicate status. Each applicable item in the checklist shall be checked and acknowledged by the applicant. This is to communicate the requirement that these steps need to take place. Any items interpreted as not required for the type of submittal shall be marked N/A.
- Estimated demand on the existing system. (flow and pressure required)
- Name and contact information for Developer, including name, address, phone number, email address.
- Name and contact information for Engineer, including name, address, phone number, and email address.
- Variance requests. Any requests for variance regarding any policies, design or construction standards of the Utility shall be submitted with the plans. The variance request form shall be submitted with all documentation required to make a comprehensive review of the variance request.

3.3.3.3 Review Process

Upon receipt of the required information to make a formal application for water service installation, the Engineering staff will create the application and begin the plan review period.

The plan submittal will be reviewed for compliance to the EWSU design policies and agreement with the items in the plan submittal checklist. In addition to general plan review, the reviewer will initiate verification of adequate pressure and flow to meet the design demand and review adequacy of easements. The reviewer will make note of any deficiencies in the submittal. Comments on the review shall be forwarded to the applicant, engineer, and developer. The preferred method of communication is by email.

It is the goal of the EWSU to provide a response to any submittal within ten (10) working days.

The review process may include revisions and re-reviews and comments. The second review should be for the purpose of making sure that all comments from the first review have been addressed. If it is determined that the review comments have not been satisfactorily addressed, a face to face meeting will be requested by the EWSU staff. The engineer, applicant and developer will be expected to attend to make sure that all parties are aware of outstanding issues.

If the originally submitted plans are revised for any reason, the revised plans shall be submitted to the EWSU engineering staff for review. Examples of revisions are those required by other review agencies.

3.3.3.4 Plan Approval

Upon review and approval of the application and verification that all requirements have been met, the Engineering Staff will issue an approval of plans to the applicant. The EWSU engineering staff will forward a set of stamped approved drawings to the applicant. These drawings must be maintained at the site during construction.

3.3.3.5 Construction

Prior to construction, the following information must be provided to the utility Engineering staff:

- All fees, including front footage if required, must be paid
- Notification of contractor name, address, phone number, and email contact information provided to the Engineering staff. The Contractor must be on the Evansville Water and Sewer Utility approved contractor list. This list will be made available to the applicant and developer
- A minimum of forty-eight (48) hour notice that construction is to commence.

The Engineering staff will, upon review of the required information, notify the developer, engineer, and contractor that construction can commence.

The Utility will make arrangements to provide oversight over the construction activities to protect the interest of the utility. It is the responsibility of the developer and contractor to make sure that the construction activities conform to the approved plans, requirements of the EWSU construction standards, and the language of all applicable easements. A set of stamped approved drawings shall be maintained at the construction site. The inspector may require the drawings to be produced during an inspection.

3.3.3.6 Testing

Required testing for all water main extensions is detailed in the construction standards of this manual.

The required testing for any water main extension is as follows:

- Hydrostatic testing for leakage
- Disinfection

For disinfection, a chlorination plan must be submitted to the EWSU engineering staff prior to requesting disinfection. The chlorination plan shall provide detail on location of chlorine injection point(s) and sampling point(s). This plan will be used by the EWSU staff to disinfect the main extension prior to activation. Upon acceptable sampling results from bacteriological testing, the EWSU will issue a notice of activation.

A minimum of forty-eight (48) hour notice shall be provided to the EWSU Engineering staff prior to any testing. The staff will make arrangements to witness all testing for the purpose of verifying compliance.

Testing procedures are detailed in the construction section of this manual and shall be strictly followed. All testing results shall be forwarded to the EWSU engineering department.

3.3.3.7 Acceptance Procedure

Upon completion of the construction activities, the developer/applicant, engineer, or contractor may make a formal request for final inspection. Prior to final inspection the following items must be complete:

- As-Built drawings detailing the plan and profile, as constructed
- GIS information (coordinates)

- All testing and disinfection
- Acceptance guarantee letter – guaranteeing the work for a period of one year

The EWSU will arrange for a final inspection of the service installation. The contractor is required to attend the inspection. The developer, engineer, and owner are all welcome to attend the final inspection walk-through. The inspector will develop a punch list of all items that require further work to bring the project into compliance with the plans and construction standards of the EWSU.

Upon completion of the work identified in the punch list, the developer, engineer, or contractor shall request a final inspection. It is expected that the final inspection will be for the purpose of inspecting the items on the punch list that have been completed. If it is determined that there are items on the punch list that have not been completed, without proper documentation as to why, a formal face to face meeting will be required. The meeting shall be attended by the developer, contractor, and engineer.

After all work is in compliance with the stamped approved plans, the service has passed disinfection, and the acceptance guarantee letter has been received, the Utility Engineering staff will send the project to the Utility Board for acceptance into the water main inventory of the Utility.

The Board will send notification to the applicant that the project has been accepted and the one year warranty period will commence. The Engineering staff will notify the Area Planning Commission that the letter of credit can be released.

3.3.3.8 Warranty Period

The project is to be warranted by the applicant for a period of one year from the date of acceptance of the main extension.

During the warranty period, the Utility may make periodic inspections of the project. If any deficiencies due to construction are noted, the developer will be contacted by the Utility. A notice of warranty deficiency will be issued. The developer shall have 30 days to remedy the issue or provide a schedule to remedy. If the warranty is not honored, the EWSU reserves the right to turn the water supply off.

Evansville Water and Sewer Utility QC/QA Submittal Checklist			
Water <input type="checkbox"/> Sewer <input type="checkbox"/> Water Service <input type="checkbox"/>	Project Name:	Date:	Keyword:
Developer:	Engineer/Applicant:		EWSU No.:
Developer Email:	Engineer/Applicant Email:		Contractor:
Developer Phone:	Engineer Phone:		Contractor Email:
			Contractor Phone:

Major Submittals Required During the Development of this Project	Date of Items Submitted/Resubmitted	Approved	EWSU Comments (For Utility Use)
1. Plans (See Checklist) * <input type="checkbox"/> Yes <input type="checkbox"/> No		<input type="checkbox"/>	
2. Letter of Credit <input type="checkbox"/> Yes <input type="checkbox"/> No		<input type="checkbox"/>	
3. IDEM/Capacity Letter Copy <input type="checkbox"/> Yes <input type="checkbox"/> No		<input type="checkbox"/>	
4. NOI/Pressure Testing & Calculations <input type="checkbox"/> Yes <input type="checkbox"/> No		<input type="checkbox"/>	
5. Off-Site Easements/Plat <input type="checkbox"/> Yes <input type="checkbox"/> No		<input type="checkbox"/>	
6. EWSU/Developer Installed Services <input type="checkbox"/> Yes <input type="checkbox"/> No		<input type="checkbox"/>	
7. Inspection Firm Notification by EWSU <input type="checkbox"/> Yes <input type="checkbox"/> No		<input type="checkbox"/>	
8. Construction Start Notification <input type="checkbox"/> Yes <input type="checkbox"/> No		<input type="checkbox"/>	
9. Water/Sewer Testing (See Checklist) <input type="checkbox"/> Yes <input type="checkbox"/> No		<input type="checkbox"/>	
10. Record Drawings (See Checklist) <input type="checkbox"/> Yes <input type="checkbox"/> No		<input type="checkbox"/>	
11. Final Inspection Request <input type="checkbox"/> Yes <input type="checkbox"/> No		<input type="checkbox"/>	
12. GIS Information <input type="checkbox"/> Yes <input type="checkbox"/> No		<input type="checkbox"/>	
13. Recorded Easements/Plat <input type="checkbox"/> Yes <input type="checkbox"/> No		<input type="checkbox"/>	
14. Engineer's Certification Letter <input type="checkbox"/> Yes <input type="checkbox"/> No		<input type="checkbox"/>	
15. Value and Deficiency Letter <input type="checkbox"/> Yes <input type="checkbox"/> No		<input type="checkbox"/>	
16. Acceptance for Maintenance <input type="checkbox"/> Yes <input type="checkbox"/> No		<input type="checkbox"/>	

* Minimum required to start a project application

As the applicant representative, I have reviewed the attached project information identified on this QC/QA submittal checklist along with the individual item checklists. These submittal items are complete within current Utility policy (unless identified otherwise) to the best of my knowledge. This form required with all submittals.

Applicant Representative _____ Date _____

Figure 3-1 QC/QA Submittal Checklist

	Minimum Sanitary Sewer Construction Plan Requirements Checklist	
Created: January 2015 Revised: _____		
Project Name: _____ Date: _____ Project Number: _____ Submitted by: _____ _____ Engineering Representative: _____ Dates: Received: _____ Returned: _____ Approved: _____		
The Engineering Representative shall check each item to indicate it has been shown or addressed on the construction plans. If an item is not applicable or not required, indicate with a N/A in the space provided.		
_____ 100-yr floodplain line _____ Backfill type _____ Bench marks _____ Bench mark datum _____ Blue line stream crossing _____ Developer name/address/ phone number _____ Drop inlets _____ Easements labeled _____ Easement plat _____ Electric lines, existing _____ Engineer's seal & signature _____ Existing ground _____ Existing sewers _____ Existing utility crossings _____ Water Lines _____ Telephone lines _____ Cable TV _____ Electric _____ Gas lines _____ Flow arrows	_____ Floodway line _____ House/lot number _____ Invert elevation _____ Legend _____ Line designation _____ Location map _____ Lot lines, Lease lines _____ Manhole designations _____ Manhole stations _____ Meets minimum standards for land surveying _____ North arrow _____ Pavement cut limits _____ Pipe type _____ Plan date _____ Proposed grade (of ground) _____ Proposed street grades _____ Railroad lines, existing _____ Rights-of-way, existing _____ Rim elevation (M.H.) _____ Scale/graphic scale	_____ Sewer grades _____ Sewer sizes _____ Soil borings _____ Special construction notes _____ Special details _____ Standard notes _____ Stationing _____ Storm drains, existing _____ Street names _____ Stubs _____ Survey baseline _____ Surveyor's seal & signature _____ Surveyor's certification _____ Tie-in point to existing system _____ Title block/sheet _____ Topo, existing _____ Tree protection indicated as required

Figure 3-2 Minimum Sewer Plan Submittal Checklist

	Minimum Water Construction Plan Requirements Checklist																																																									
Created: January 2015 Revised: _____																																																										
Project Name: _____ Date: _____ Project Number: _____ Submitted by: _____ _____ Engineering Representative: _____ Dates: Received: _____ Returned: _____ Approved: _____																																																										
The Engineering Representative shall check each item to indicate it has been shown or addressed on the construction plans. If an item is not applicable or not required, indicate with a N/A in the space provided.																																																										
<table style="width: 100%; border: none;"> <tr> <td style="width: 33%;"><input type="checkbox"/> 100-yr floodplain line</td> <td style="width: 33%;"><input type="checkbox"/> Existing utility crossings</td> <td style="width: 33%;"><input type="checkbox"/> Proposed street grades</td> </tr> <tr> <td><input type="checkbox"/> Air & Vacuum relief valve location</td> <td><input type="checkbox"/> Water Lines</td> <td><input type="checkbox"/> Railroad lines, existing</td> </tr> <tr> <td><input type="checkbox"/> Bench marks</td> <td><input type="checkbox"/> Telephone lines</td> <td><input type="checkbox"/> Rights-of-way, existing</td> </tr> <tr> <td><input type="checkbox"/> Bench mark datum</td> <td><input type="checkbox"/> Cable TV</td> <td><input type="checkbox"/> Scale/graphic scale</td> </tr> <tr> <td><input type="checkbox"/> Blow-off points, permanent</td> <td><input type="checkbox"/> Electric (buried)</td> <td><input type="checkbox"/> Soil borings</td> </tr> <tr> <td><input type="checkbox"/> Blow-off points, temporary</td> <td><input type="checkbox"/> Electric (OH)</td> <td><input type="checkbox"/> Special construction notes</td> </tr> <tr> <td><input type="checkbox"/> Blue/line stream crossing</td> <td><input type="checkbox"/> Gas lines</td> <td><input type="checkbox"/> Standard notes</td> </tr> <tr> <td><input type="checkbox"/> Chlorination points</td> <td><input type="checkbox"/> Floodway lines</td> <td><input type="checkbox"/> Stationing</td> </tr> <tr> <td><input type="checkbox"/> Developer name/address/ phone number</td> <td><input type="checkbox"/> House/lot number</td> <td><input type="checkbox"/> Street names</td> </tr> <tr> <td><input type="checkbox"/> Easements labeled</td> <td><input type="checkbox"/> Hydrants, existing</td> <td><input type="checkbox"/> Survey baseline</td> </tr> <tr> <td><input type="checkbox"/> Easement plat</td> <td><input type="checkbox"/> Hydrants, proposed</td> <td><input type="checkbox"/> Tie-in point to existing system</td> </tr> <tr> <td><input type="checkbox"/> Engineer's seal & signature</td> <td><input type="checkbox"/> Legend</td> <td><input type="checkbox"/> Title block/sheet</td> </tr> <tr> <td><input type="checkbox"/> Existing ground</td> <td><input type="checkbox"/> Location map</td> <td><input type="checkbox"/> Topo, existing</td> </tr> <tr> <td><input type="checkbox"/> Existing sanitary sewers</td> <td><input type="checkbox"/> Lot lines, Lease Lines</td> <td><input type="checkbox"/> Tree protection indicated as required</td> </tr> <tr> <td><input type="checkbox"/> Existing storm sewers</td> <td><input type="checkbox"/> North arrow</td> <td><input type="checkbox"/> Valves, existing</td> </tr> <tr> <td></td> <td><input type="checkbox"/> Pavement cut limits</td> <td><input type="checkbox"/> Valves, proposed</td> </tr> <tr> <td></td> <td><input type="checkbox"/> Pipe type</td> <td></td> </tr> <tr> <td></td> <td><input type="checkbox"/> Pipe size</td> <td></td> </tr> <tr> <td></td> <td><input type="checkbox"/> Proposed grade (of ground)</td> <td></td> </tr> </table>		<input type="checkbox"/> 100-yr floodplain line	<input type="checkbox"/> Existing utility crossings	<input type="checkbox"/> Proposed street grades	<input type="checkbox"/> Air & Vacuum relief valve location	<input type="checkbox"/> Water Lines	<input type="checkbox"/> Railroad lines, existing	<input type="checkbox"/> Bench marks	<input type="checkbox"/> Telephone lines	<input type="checkbox"/> Rights-of-way, existing	<input type="checkbox"/> Bench mark datum	<input type="checkbox"/> Cable TV	<input type="checkbox"/> Scale/graphic scale	<input type="checkbox"/> Blow-off points, permanent	<input type="checkbox"/> Electric (buried)	<input type="checkbox"/> Soil borings	<input type="checkbox"/> Blow-off points, temporary	<input type="checkbox"/> Electric (OH)	<input type="checkbox"/> Special construction notes	<input type="checkbox"/> Blue/line stream crossing	<input type="checkbox"/> Gas lines	<input type="checkbox"/> Standard notes	<input type="checkbox"/> Chlorination points	<input type="checkbox"/> Floodway lines	<input type="checkbox"/> Stationing	<input type="checkbox"/> Developer name/address/ phone number	<input type="checkbox"/> House/lot number	<input type="checkbox"/> Street names	<input type="checkbox"/> Easements labeled	<input type="checkbox"/> Hydrants, existing	<input type="checkbox"/> Survey baseline	<input type="checkbox"/> Easement plat	<input type="checkbox"/> Hydrants, proposed	<input type="checkbox"/> Tie-in point to existing system	<input type="checkbox"/> Engineer's seal & signature	<input type="checkbox"/> Legend	<input type="checkbox"/> Title block/sheet	<input type="checkbox"/> Existing ground	<input type="checkbox"/> Location map	<input type="checkbox"/> Topo, existing	<input type="checkbox"/> Existing sanitary sewers	<input type="checkbox"/> Lot lines, Lease Lines	<input type="checkbox"/> Tree protection indicated as required	<input type="checkbox"/> Existing storm sewers	<input type="checkbox"/> North arrow	<input type="checkbox"/> Valves, existing		<input type="checkbox"/> Pavement cut limits	<input type="checkbox"/> Valves, proposed		<input type="checkbox"/> Pipe type			<input type="checkbox"/> Pipe size			<input type="checkbox"/> Proposed grade (of ground)	
<input type="checkbox"/> 100-yr floodplain line	<input type="checkbox"/> Existing utility crossings	<input type="checkbox"/> Proposed street grades																																																								
<input type="checkbox"/> Air & Vacuum relief valve location	<input type="checkbox"/> Water Lines	<input type="checkbox"/> Railroad lines, existing																																																								
<input type="checkbox"/> Bench marks	<input type="checkbox"/> Telephone lines	<input type="checkbox"/> Rights-of-way, existing																																																								
<input type="checkbox"/> Bench mark datum	<input type="checkbox"/> Cable TV	<input type="checkbox"/> Scale/graphic scale																																																								
<input type="checkbox"/> Blow-off points, permanent	<input type="checkbox"/> Electric (buried)	<input type="checkbox"/> Soil borings																																																								
<input type="checkbox"/> Blow-off points, temporary	<input type="checkbox"/> Electric (OH)	<input type="checkbox"/> Special construction notes																																																								
<input type="checkbox"/> Blue/line stream crossing	<input type="checkbox"/> Gas lines	<input type="checkbox"/> Standard notes																																																								
<input type="checkbox"/> Chlorination points	<input type="checkbox"/> Floodway lines	<input type="checkbox"/> Stationing																																																								
<input type="checkbox"/> Developer name/address/ phone number	<input type="checkbox"/> House/lot number	<input type="checkbox"/> Street names																																																								
<input type="checkbox"/> Easements labeled	<input type="checkbox"/> Hydrants, existing	<input type="checkbox"/> Survey baseline																																																								
<input type="checkbox"/> Easement plat	<input type="checkbox"/> Hydrants, proposed	<input type="checkbox"/> Tie-in point to existing system																																																								
<input type="checkbox"/> Engineer's seal & signature	<input type="checkbox"/> Legend	<input type="checkbox"/> Title block/sheet																																																								
<input type="checkbox"/> Existing ground	<input type="checkbox"/> Location map	<input type="checkbox"/> Topo, existing																																																								
<input type="checkbox"/> Existing sanitary sewers	<input type="checkbox"/> Lot lines, Lease Lines	<input type="checkbox"/> Tree protection indicated as required																																																								
<input type="checkbox"/> Existing storm sewers	<input type="checkbox"/> North arrow	<input type="checkbox"/> Valves, existing																																																								
	<input type="checkbox"/> Pavement cut limits	<input type="checkbox"/> Valves, proposed																																																								
	<input type="checkbox"/> Pipe type																																																									
	<input type="checkbox"/> Pipe size																																																									
	<input type="checkbox"/> Proposed grade (of ground)																																																									

Figure 3-3 Minimum Water Plan Submittal Checklist

	Early Coordination Checklist Sanitary Sewer
Created: January 2015 Revised:	
Project Name: _____ Contact Person: _____ Phone Number: _____ Engineering Representative: _____	
<p>SUBMITTAL REQUIREMENTS</p> <ol style="list-style-type: none"> 1. Will the sewer constructed to serve this development serve any other areas? <input type="checkbox"/> Yes <input type="checkbox"/> No 2. Will any sewers larger than 8" be constructed as part of this project? <input type="checkbox"/> Yes <input type="checkbox"/> No 3. Will a public lift station be built to serve this development? <input type="checkbox"/> Yes <input type="checkbox"/> No 4. Will any sewers be designed at less than minimum slope? <input type="checkbox"/> Yes <input type="checkbox"/> No 5. Approximate boundaries of proposed development. 6. Intended land use of the property. 7. Estimated sanitary sewer flow for the development. 8. Desired point of connection, if known. <p>An Early Coordination Diagram must be submitted with this form.</p> <p>COMMERCIAL AND INDUSTRIAL WASTES AND DISCHARGES</p> <ol style="list-style-type: none"> 1. Is the user federally categorized? <input type="checkbox"/> Yes <input type="checkbox"/> No If yes, FIC Code _____ 2. Will any pretreatment be needed? <input type="checkbox"/> Yes <input type="checkbox"/> No 	

Figure 3-4 Sanitary Sewer Early Coordination Checklist

	Early Coordination Checklist Water
Created: January 2015 Revised:	
<p>Project Name: _____</p> <p>Contact Person: _____</p> <p>Phone Number: _____</p> <p>Engineering Representative: _____</p> <p>SUBMITTAL REQUIREMENTS</p> <p>1. Will the water main provide fire protection? <input type="checkbox"/> Yes <input type="checkbox"/> No</p> <p>2. How many proposed service connections will be on the new main? _____ Residential</p> <p style="text-align: right;">_____ Commercial</p> <p style="text-align: right;">_____ Industrial</p> <p>3. Will this project require the replacement or relocation of any existing water mains? <input type="checkbox"/> Yes <input type="checkbox"/> No</p> <p>4. Approximate boundaries of the proposed development.</p> <p>5. Intended land use of the proposed development.</p> <p>6. Estimated daily demand for the development.</p> <p>7. Desired point of connection to the existing system.</p> <p>8. For large service connections, desired point of connection.</p> <p> </p> <p>An Early Coordination Diagram must be submitted with this form.</p>	

Figure 3-5 Water Early Coordination Checklist

SECTION 4: Engineers

4.1 Survey

4.1.1 Purpose

The intent of this section is to provide the developer, private property owner, consulting engineer or any party looking to develop land that will require additions to the EWSU service system, with a minimum set of guidelines for the survey aspect of their projects. By following these recommended best management practices, the developing party can be ensured that interaction with the EWSU's Engineering Department will be as smooth and seamless as possible.

This chapter discusses the tasks associated with field surveys that are recommended for design, construction, acceptance, and approval of EWSU Projects. Projects initiated by private entities such as land developers, private property owners, or other such parties, requiring EWSU approval and/or acceptance of constructed facilities, should follow these guidelines. Design engineers and survey crew chiefs hired by the aforementioned private entities should familiarize themselves with this document and all other chapters of these Standards prior to commencing any field survey work. Familiarity with these requirements will enable field survey crews to efficiently obtain the recommended field information for design and construction while minimizing unnecessary or redundant activities.

4.1.2 General

The survey crew is normally the first set of project representatives to come in contact with the property owners and residents along the route of the proposed project. It is imperative that the survey crew members conduct themselves professionally, both on the project site and in the surrounding community.

Proposed work should be explained to the affected property owners/residents and to the general public, as necessary for the surveyor crew to do his job. However, the survey crew should refrain from outlining any specific plans or policies or privileged information that might be misconstrued or misunderstood by individual property owners. If approached, the survey crew should not convey any project specific information to the general public. If a citizen has project-specific questions, he or she should be referred to either the surveyor's contract client or the EWSU Engineering Department.

The survey crew must be courteous at all times when engaged with the public. Crew members shall maintain a record of the names of owners/residents with whom they converse. During owner/resident conversations, the survey crew should inquire about the location of survey corners or monuments located on the subject property. All such inquiries shall be noted in a field book even if they are in error and just perceived as corners or monuments by members of the general the public.

4.1.3 Survey Notification

Notification to property owners/residents is expected when the survey crew must gain access to private property that is off-site from the subject project. The developer's consultant conducting the survey shall be responsible for the notifications. The notification should be sent to all of the property owners within the project limits, adjacent to the project, or having lands that must to be accessible to the Professional Surveyor.

4.1.4 Horizontal and Vertical Control

Project control should be established by setting temporary project control points with horizontal and vertical coordinates. Temporary project control points should be tied to either found property monuments and visible evidence of possession, or documented control points such as section corners, subdivision corners, control points established during route surveys, or other control points previously documented by the EWSU, INDOT, USGS, or some other bona fide organization of note.

4.1.4.1 U.S. Survey Foot

All references to “foot” or “feet” in this document shall mean US survey foot, the basis for the Indiana State Plane Coordinate System, subject to change to INGS as per INDOT.

4.1.4.2 Guidelines

Horizontal and vertical control shall be established according to the guidelines defined by the following publications:

- Federal Geodetic Control Committee (FGCC), Standards and Specifications for Geodetic Control Networks;
- NOAA Technical Report NOS 88 NGS 19, Horizontal Control;
- NOAA Manual NOS NGS 3, Geodetic Leveling;
- FGCC, Geometric Geodetic Accuracy Standards and Specifications Using GPS Relative Positioning Techniques (or its subsequent revisions); and
- The Route Surveying Portion of Rule 12 as defined in Title 865 IAC 1-12-12 thru 1-12-26.

4.1.4.3 Datum

All control should be related to existing monuments that have been approved the EWSU, INDOT, USGS, or some other bona fide organization of note and should reference the appropriate datum as indicated below:

- Horizontal control shall be referenced to the Indiana State Plane Coordinate System, Zone West Zone/NAD (1983), subject to change to INGS as per INDOT.
- Vertical control shall be referenced to North American Vertical Datum (NAVD) 1988 unless otherwise requested.

4.1.4.4 Location Witness

All project horizontal control points, whether permanent or temporary, should be witnessed to the nearest one-hundredth of a foot, at three or more exactly definable points on permanent structures with no reference being more than one hundred feet from the control point. If no permanent structures are nearby, two or more exactly definable points may be set and occupied for measurement of angle and distance from each other to the control point. Each line of sight is to have an exactly definable back sight.

All benchmarks should be exactly defined and referenced to the survey project control points in addition to other field references such as established addresses, or other such site features, in field notes, plans, and any other pertinent documents submitted.

4.1.4.5 Degree of Accuracy

Horizontal surveys should adhere to Third Order, Class I specifications, except that adjustments may be made by either the Least Squares or Compass Rule Method. Vertical control should adhere to Third Order specifications, except that the error of closure will be equal to or exceed Second Order, Class II requirements. The specified criteria for surveys may vary according to their purpose. All surveys are subject to conformance with Title 865 IAC 1-12-22.

The instruments used should meet the specifications indicated in these guidelines or in subsequent articles of this document. All instruments should be certified to National Institute of Standards and Technology standards and manufacturer's specifications.

4.1.4.6 Control Points

Control points used for the completion of surveys may be existing\recorded monuments, or temporary control points set specifically for the project. The following articles outline the requirements for control points:

- a. Temporary Project Control Points (TCPs) and Temporary Benchmarks (TBMs) should be distinct from horizontal and vertical control monuments. TCPs may consist of, but not necessarily be limited to, the following:
 - A 2-inch minimum masonry nail in pavement,
 - Iron or steel rebar with cap.
- b. TBMs should be established at a maximum of 500-feet and shall be located within a public easement or right-of-way. Acceptable TBMs include, but are not necessarily limited to, the following:
 - A 2-inch minimum masonry nail in pavement,
 - A bolt on a fire hydrant which is not used for operation of the hydrant, and
 - A painted or etched box or "x" in a curb, sidewalk, or other concrete structure.
- c. Documented Control Point Placement

There should be a minimum of three horizontal control points. All horizontal control should be located within the easement or public right-of-way. Each monument should be placed to avoid movement caused by construction or other activities. Each and every horizontal control monument should also be a vertical control and shall be set per Title 865 IAC 1-12-24(1).

Vertical control monuments should be placed similarly to horizontal control monuments at maximum intervals of 500 feet. When horizontal-vertical control monuments are also set, they should be considered vertical control monuments. For projects less than 1,000 feet in length, the

requirements for the placement of horizontal and vertical control should conform to Title 865 IAC 1-12-24(1).

d. Documented Control Point Monumentation

Monumentation of documented horizontal and vertical control points should meet or exceed the requirements of Title 865 IAC 1-12-24 (2 thru 6). Standard permanent vertical control of benchmarks, consisting of a 3½ inch diameter, or larger, domed disk set in the top of a 12 inch x 36 inch poured concrete post should be used when vertical control monuments are specifically requested.

e. Documented Control Point Horizontal and Vertical Control Approval

When the final control work has been completed and checked, all computations should be indexed and bound in a neat and orderly fashion, along with hard copies and computer disks/flash drives of the actual field notes and all related drawings

f. Documented Control Point Horizontal and Vertical Control Map (Route Survey Plat)

A horizontal and vertical control map, otherwise known as a route survey plat, is required for all surveys completed for off-site sanitary sewer projects and potable water main projects. Each route survey plat shall be prepared on a standard plan sheet and shall be included in the final plans. The final route survey plat shall include final stations, station equations, all curve data, and the final location and description of benchmarks.

Horizontal and vertical control information placed on the route survey plat shall be in accordance with Title 865 IAC 1-12-23, "Publication of Route Survey Results." The plat shall be submitted to the Vanderburgh County Recorder's Office and shall conform to the requirements and specifications of the Vanderburgh County Recorder.

Required horizontal information includes:

- Angles at all baseline points of intersection and ties to available acceptable monuments,
- Bearings and distances on the final project centerlines and available baselines,
- Angles and stations with adjacent projects,
- Final coordinates (State plane or assumed),
- All bearings, coordinates, angles and point designations on baselines in the design segment,
- Source of horizontal control,
- Any and all monuments marking the Public Land Surveying System as can be recovered with reasonable effort, and
- All monuments marking subdivided lots, centerline control, and public project centerlines or baselines.

Vertical information to be shown includes:

- New benchmarks - their designations, locations, descriptions and elevations;
 - USGS, City or County benchmarks - their designations, elevations and locations; and
 - Sources of vertical control.
- g. Drawings and Field Notes of Desired Survey Locations

Survey drawings, for all projects to be approved and accepted by the EWSU, shall be provided to the EWSU. All control points, benchmarks, and topographic features shall be clearly identified.

4.1.5 Survey Information and Data Collection

Recommendations for survey information and data collection for EWSU Projects have been developed to accurately define and assess the areas to be impacted by proposed projects. The following articles discuss the criteria governing survey information and data collection.

4.1.5.1 Area to be Surveyed

Prior to the initiation of field activities, the extent of the survey and the survey limits can be coordinated with the EWSU, if desired. Survey corridors and routes can be developed specifically for each project. The area or corridor defined for surveys should be sufficient in size to identify all physical characteristics of the project's topography.

Each survey should include a sufficient number of shots, located approximately 10 to 20-feet, outside the existing right-of-way or survey corridor to assess the impacts of proposed limits on adjacent areas.

4.1.5.2 Physical Features to be Identified

All topography and accompanying physical features, critical to the design of and potentially affected by, the improvement should be located and recorded in the field notes. The requirements for the location of man-made and natural physical features on the proposed survey should always be discussed prior to mobilization of field activities.

Topography generated from aerial photography shall be identified and field checked for any potential errors or omissions. Omitted topography shall be located by field survey and appropriately recorded. This work should be the specific responsibility of the developer's Engineer or Professional Surveyor, even though the aerial photography may have been provided from other sources. All topography within the proposed project construction limits and/or easements and rights-of-way should be field located and verified.

4.1.5.3 Survey Information Needed for Trees

The following information should be provided for trees within the proposed survey boundaries.

- Species of Tree (Use the Audubon Society Field Guide to North American Trees, Eastern Region")
- Size (Trunk DBH - Diameter at Breast Height)

- Dripline (Diameter)
- Location:
 - All trees 6 inches in diameter or greater and within 30-feet of the centerline of the pipe or 30-feet outside the toe of slope of ditches should be located and the species given.
 - All trees less than 6-inches in diameter shall be located and species given, when within an existing or proposed sewer, water or drainage easement.
 - When trees are grouped together at a very close interval, locate the approximate limits of the grouping and list the most dominant species of the group.

4.1.5.4 Field Profile Requirements

All field topography and profile activities should comply with 865 IAC 1-12. Profile elevations should be determined along sanitary sewers and potable water mains. Survey points, to support the generation of profiles, should be collected at intervals of 25-feet (nominally), where possible; at intervals of 50-feet (nominally) on paved streets, and at all intermediate breaks. Profiles shall delineate existing structures, roads, streams, and other important physical features. Elevations should be established to the nearest one-tenth of a foot on natural terrain and to one-hundredth of a foot on artificial, man-made surfaces.

4.1.5.5 Cross sections

Cross sections should be generated at 50-foot intervals and as needed at critical locations where it is necessary to determine the effect open cuts or trenching may have on existing facilities such as structures, utilities, pavements, fences, trees, or landscaping. Survey points should be taken to support the accurate generation of the cross sections. Sufficient original ground elevations should be determined in order to establish the slopes necessary to adequately serve the property.

4.1.5.6 Subsurface and Overhead Utilities

All publicly and privately owned subsurface and overhead utilities affected by the proposed project should be located and identified by field survey and by use of maps supplied by the utilities. Locations, elevations, and other pertinent data that may be required for possible relocation or adjustment should be secured for all such utilities, within the limits of information currently available.

The survey crew should request that the underground utilities be marked by calling the Indiana Underground Plant Protection Services (811). The ticket number for the location request should be documented and submitted with the plans.

All sewer manhole structures within the survey corridor should be surveyed. The next structures upstream/downstream from the survey corridor should also be surveyed. Manholes are considered confined spaces per OSHA and should only be entered by utilizing appropriate procedures and qualified personnel.

Overhead power lines shall be accurately located within the survey corridor. The sag elevation of the overhead lines between poles shall be documented.

4.1.5.7 Summary of Topographic Survey Elements

Licensed Engineer or Professional Surveyors should complete topographic survey data along the proposed project corridor, including the natural and man-made features of the land, as well as its elevations.

Facilities to be located should include but are not necessarily be limited to the following:

- Power poles and supports,
- Sanitary and storm sewer manhole rim and invert elevations,
- Utility locations as marked by Indiana 811,
- Water valves, valve vaults and hydrants,
- Electrical vaults,
- Traffic signal equipment, and
- Storm water inlet and catch basin rim and invert elevations.

Data from all utility location procedures, marked on the site from “Indiana 811,” should include horizontal locations and depths where the information is readily available or discernible. The “Indiana 811” service shall be notified 48 hours prior to any necessity for verification of location, size, and material.

All sewer structures should be sketched and structure data details determined to show pipe size, number, flow direction, and invert elevation, Structures should then be referenced to the horizontal notes with a reference point.

Location should be determined for all existing natural and man-made features such as bridges, rivers, ponds, trees, landscaping, driveways, edge of pavements, curb and gutters, sidewalks, edge of buildings, fences, signs, guardrails, street lights, existing top of bank and toe of slope.

Curved features, such as a curved roadway, should have sufficient points collected in the field to depict accurately the field condition on the base plan.

The design/construction centerline for all roads affected by the project should be established and referenced.

At least two (2) horizontal control points will be necessary for projects 500 feet or less in length. The distance between referenced control points should not exceed 1,000-foot intervals for projects greater than 500 feet long.

Control points should be semi-permanent in nature (PK nails, RR spikes, iron rods, etc.) and be witnessed to at least three other permanent objects.

All projects should be tied to the same vertical datum, North American Vertical Datum 1988 (NAVD 88) as per the current FEMA Flood Insurance Rate Maps.

Horizontal datum coordinates should be Indiana State Plane Coordinates Zone West, North American Datum 1983 (NAD83), subject to change to INGS as per INDOT.

Each project should have at least one (1) temporary benchmark for projects 500 feet or less in length for vertical control. The spacing of temporary benchmarks should not exceed 750 feet for projects with a length greater than 500 feet.

Notes relating to vertical positions should include data on all benchmarks established and should provide reference to the source of the control. Benchmarks should be described and/or sketched to ensure proper identification. Elevation notes should also include a periodic check from benchmark control to traverse points to ensure the data collector is recording accurate elevations.

Property ownership/addresses and apparent property lines for right-of-way should be established.

Provide sufficient control for the contractor to layout the proposed work.

All ground features pertaining to or affecting the required end product should be collected as part of the field effort.

Most building dimensions and other data and comments that cannot be recorded in an electronic field book shall be noted as a sketch in a field book. While the sketches will not require the minute dimensions and detail once necessary for a manual survey, they should be explicit enough so that the Design Engineer can orient position on the electronic drawing and complete the topographic map/base plan.

Building footprints should include overhangs and cantilevered improvements at elevations higher than natural grade.

After the topographical field survey is completed, the recorded data should be processed using a compatible software package, and drafting standards approved by the EWSU, to create the topographic map/base plan.

Apparent property corners located in the field should be shown on the base plan. Owners' names, addresses, and deed references should be shown along with approximate property lines pertaining to the project.

Layout data should be shown on the base plan indicating the coordinates, bearing, distances and stations between changes in the geometry of the alignment.

All coordinate values should be to four (4) decimal places; linear values and elevations should be to two (2) decimal places; and direction bearings shall be to the second.

4.1.6 Special Surveys and Topographical Information

4.1.6.1 Property Surveys

Surveys covered by the recommendations of this article include: route, original, and retracement surveys.

Where the relationship of the project's location and adjacent property line is critical, the location of the existing property line and other boundaries should be established by a property survey sufficient to define the easement. All property surveys should comply with the "Minimum Standards for Competent Practice for Land Surveying in Indiana" and Title 865 IAC Rules 1-12. Plats and descriptions for easements should conform to the requirements defined in this manual.

4.1.6.2 Railroad and Highway Surveys

When the centerline of a proposed linear project such as sewer lines or water mains, crosses a railroad or highway, all existing and proposed railroad tracks, roadways and affected structures should be tied to the centerline of the proposed project. The topography data should be collected on both sides of the proposed crossing to the extent required by the affected reviewing agencies.

4.1.6.2.1 Railroads

Information for railroads should include, but not necessarily be limited to, the following:

- Top of rails - 300 feet minimum in either direction to be located horizontally and vertically at 50 foot intervals,
- Angle between centerline of tracks and centerline of improvement,
- Name and address of railroad company,
- Location of railroad rights-of-way and easements (source of record where possible),
- Horizontal information relative to transmission lines, such as telephone or electric (when possible),
- Stations on the centerline of each track, and
- Mile post locations, measured from centerline crossing.

Permission to be on the railroad right-of-way should be secured from the railroad company prior to entering the right-of-way. It should be noted that trespassing on railroad right-of-way is a Class D felony.

4.1.6.2.2 Highways (INDOT Controlled Roadways)

Information for highways should include, but not necessarily be limited to, the following:

- Station on centerline of highway and each edge of pavement, or front face of curb, as may be appropriate;
- Angle between centerline of highway and centerline of improvement,
- Location of highway rights-of-way and easements (source of record where possible),
- Location of any crossings, or parallel utilities, or drainage structures which may be in conflict with the improvement construction, and
- Number and width of lanes and the type and condition of the surface.

Additional information relative to requirements in the vicinity of railroads and highways may be required on a project specific basis.

4.1.7 Construction Staking

4.1.7.1 Construction Staking

The staking of all baselines, control points, monuments, and all other items associated with the plans for proposed project construction, prior to the initiation of construction, should be the responsibility of the Contractor. The staking of all proposed work shall comply with Title 865 IAC. (Reference is Property Interest Surveys only.) Specific items that should be staked and identified in the field prior to construction activities include:

- Proposed permanent, temporary and construction easements, and project control points and monuments.

4.2 Easements

4.2.1 Purpose

The intent of this section is to outline the requirements for easements and provide developers, property owners, consulting engineers or other similar parties with the EWSU's minimum set of criteria for determining easements size, location and usage.

All sanitary collection systems and water distribution systems that are to be publicly owned, operated, and/or maintained shall be constructed in rights-of-way, easements, or on properties owned (or will be accepted) by the City of Evansville. No approval will be given for construction of or improvements to any EWSU infrastructure components without provisions for suitable permanent easements or rights-of-way.

4.2.2 Existing Easements

Existing easements shall be identified and marked accordingly on construction plans. Minimum construction plan requirements include the following:

- The location, dimensions, and specified use of each existing easement; and
- The recording information of the existing easement, including the document number or the book and page of the existing easement as found in the Office of the Vanderburgh County Recorder.

An existing easement that is an exclusive use easement for gas, electric, or other non-City owned utility does not permit the construction of a sanitary collection system or a potable water distribution system. In such a case, an alteration or new easement must be signed by the property owner and the beneficiary of the existing exclusive use easement.

Special attention shall be given to the types of easements. Some existing easements are specifically for drainage, potable water, sanitary sewer, or any combination thereof. Such easements can only be utilized for the uses specified. For example, a water line cannot be placed in an easement specified as a surface drainage easement. In such an instance, a new water line easement shall be acquired and noted on the construction plans in the same manner as any other new easement.

Recording information for existing easements, such as document number or book and page number, shall be shown on the drawings.

4.2.3 Types of Interest in Real Property for EWSU

The following terms apply to the acquisition of interest(s) in real property for the purposes of construction, operating, and maintaining drainage, sanitary sewer, wastewater treatment, and potable water facilities.

4.2.3.1 Fee Simple Title

Fee simple title signifies specific ownership of the land. There can be encumbrances to fee simple title such as easements, zoning classification, and other limitations on use. Fee simple title is usually established by a recorded deed.

For the purpose of constructing major aboveground structures, the EWSU will normally acquire the property in fee simple title. Examples of projects that require fee simple title are pumping stations, wastewater treatment plant sites, potable water production facilities, major detention basins, and other miscellaneous projects of similar scope.

4.2.3.2 Sanitary Sewer Perpetual Easements and Potable Water Perpetual Easements

A perpetual easement is a permanent interest, in perpetuity, in real property that allows the privilege of a specific and limited use of real property that is separately owned by someone else. A recorded easement, whether dedicated on a subdivision plat or in an easement agreement, usually remains an encumbrance on the land regardless of any change in ownership of the underlying property. An easement can, in most cases, only be terminated by the grantee. The most common way that an easement terminates is by its own terms, usually by passage of a specified amount of time. Merger of Title, when the grantee purchases the land on which the grantee has an easement, also terminates an easement.

For the purpose of sanitary collection systems and potable water distribution systems, the EWSU prefers a perpetual easement. The easement shall grant the right to construct, operate, and maintain these systems within the limits of the easement's defined area. These easements shall be designated "Sanitary Sewer Easement and/or Potable Water Easement".

A perpetual easement shall not be designed to include any portion of an existing or proposed permanent structure, unless the EWSU decides otherwise, on a case-by-case basis. A property owner generally is restricted from constructing any improvements within the limits of an easement which could potentially interfere with the privileges granted by the easement.

4.2.3.3 Temporary Construction Easement

A temporary construction easement is a temporary interest in real property that allows the privilege of a specific and limited use of real property owned by someone else, for activities associated with the act of construction. Temporary construction easements generally terminate on a specific date or after the completion of a particular stated and defined accomplishment or activity.

A temporary construction easement will be required if the activities associated with the construction process cannot be completed within the confines of the perpetual easement or if vehicular access to the site is not adequate. These activities may include structure removal, ingress/egress of construction equipment and materials, stockpiling, grade adjustment, and other miscellaneous tasks.

Temporary construction easement lines may be drawn through permanent structures; however, the contract documents shall contain language clearly indicating that all such permanent structures shall not be disturbed during construction.

4.2.4 Easement Widths

Whenever possible, the total easement width, perpetual plus temporary, shall be sufficient to permit the Contractor to have flexibility in the method of construction.

Standard minimum widths of perpetual easements using trench construction are described below:

- Typical easement width shall be half the facility depth on each side of the facility measured from the outside of the facility, rounded up two feet at all critical areas.
- Easement width shall be a minimum of four feet on each side of the facility, measured from the outside of the facility.
- Easement width shall be a minimum of twelve feet total.
- Easement widths greater than twelve feet shall be rounded up in five foot increments.
- Easement widths shall be consistent between manholes on sewer projects.

In no case shall these standards be a substitute for sound engineering judgment. Lesser easement widths may be allowed upon approval of such widths by the EWSU. Justification for the lesser easement widths shall be provided.

4.2.5 Construction Plan Requirements

Construction Plans shall show:

- The locations and dimensions of all existing and proposed perpetual and temporary easements,
- That the proposed facilities or utilities will be within clearly defined easements, and
- Identification of the parcels burdened by the proposed construction and the parcels adjacent to the parcels burdened by the proposed construction, including the following information:
 - Property owners' names and addresses, and
 - Document number or book and page number of last deed of record of the parcels in question.

4.2.6 Easement Description Criteria

Easement descriptions prepared for the EWSU are to be consistent in general appearance and information provided.

4.2.6.1 General Description Elements

Easement legal descriptions are no different from legal descriptions used for fee simple documents. The same basic requirements and elements are required. Legal descriptions are to be prepared by an Indiana

registered Professional Engineer, Professional Surveyor or a real estate attorney. There are two general types of legal descriptions that may be used for EWSU projects:

- Aliquot part of a parcel, or
- Metes and bounds description of parcel.

Every legal description will have three basic parts:

- Caption,
- Body,
- Certification.

The caption is the opening clause of the legal description. It states the general locality, reference documents associated with the description, county and state of the parcel. The caption for an easement legal description shall be identical to the caption in the easement grantor's deed description, to the extent applicable.

The body shall include a legal description that states the area encumbered by the easement. This description shall be given in square feet to the nearest whole number or to the nearest one-thousandth of an acre. The body shall utilize the same qualifying calls and bounding calls as are found in the easement Grantor's last deed of record, as much as practical.

A line shall be added below the body that identifies the tax identification number for the underlying parcel.

The certification shall state who prepared the description, the patron of the description, and a date. The Professional Surveyor's signature and seal shall be included.

4.2.6.2 When Multiple Descriptions are Required

A legal description is required for each parcel, having a unique tax parcel number issued in accordance with the Vanderburgh County Assessor's Office.

4.2.6.3 Aliquot Descriptions

A common method for describing an easement within a platted area of the City is to utilize the aliquot description method. This method defines the location of the easement based on the existing boundary of the grantor's parcel and defines a width of the easement. An example is "The North xx feet of Lot yy of John's Subdivision." These types of descriptions require the easement to be parallel to a lot line or right-of-way.

The aliquot description shall only be used when the grantor's deed description is a lot or parcel defined by a plat. An aliquot description that refers back to a metes-and-bounds or perimeter description defined in a recorded deed is not acceptable. For instance, the "north xx number of feet of the grantor's lands described in Document #xxx" is not an acceptable description.

4.2.6.4 Metes and Bounds Descriptions

A metes and bounds description shall describe each course segment around the perimeter of a parcel. This procedure shall result in a geometric figure that has mathematical closure and completeness.

The metes and bounds description will require a Point of Beginning and, if necessary, a “point of commencement”. The description for the easement shall commence at the same point as the “point of commencement” identified in the easement grantor’s deed. The proposed easement description shall follow the grantor’s commencement courses and deed perimeter until it intersects a perimeter point of the easement description. This location point will be defined as the “point of beginning”.

The perimeter description courses are to be consistent with the distances and directions shown on the easement plat. The easement description is to utilize as many qualifying clauses, as practicable, to insure conformity with the grantor’s deed description. The easement description shall follow the easement perimeter in a clockwise rotational motion.

A perimeter description shall only be used when the proposed easement is not parallel to an existing lot line, or if the grantor’s deed description is not a lot or parcel defined by a plat. Per Title 865 IAC, Rule 12, a boundary land survey or a location control route survey plat is required for a metes and bounds description. An easement plat can be utilized to these ends if it meets the requirements set forth in Title 865 IAC, Rule 12. This includes, but is not necessarily limited to, setting monument corners and providing a Professional Surveyor’s report that is consistent with said established requirements.

4.2.7 Easement Plat Criteria

Easement plats are graphical representations of easements’ legal descriptions. They allow the grantors to see the easement in relation to their parcel lines.

4.2.7.1 General Requirements

Easement plats shall be prepared for each parcel on which a perpetual easement shall be acquired. A single easement plat can be utilized for several contiguous parcels having the same owner that have different tax parcel numbers. The phrase “Sanitary Sewer, Drainage, and Potable Water Easement” shall be used on all easement plats. Easement plats shall:

- Have the title for the Professional Surveyor’s certification and seal;
- Have the easement limits hatched for clarity; temporary and perpetual easements shall be hatched in a dissimilar manner in order to easily distinguish between easement types;
- Have a clear indication of the information taken from deeds and/or plats as well as information that was from calculated or measured sources;
- Have a statement to define the basis of bearings, which can be an established horizontal datum or an assumed north direction;
- Have the proper depiction of the different line types and widths for parcel lines, perpetual easements, and temporary easements;

- Have the street address, parcel Owner’s name, tax parcel number and document number, or book and page number, of the last deed of record for the affected parcel;
- Show existing easements with specific uses labeled and all pertinent recording information of the easements;
- Show all dimensions to the nearest one-hundredth of a foot;
- Shown angles or bearings to the nearest second;
- Have the easement area(s) stated, with perpetual and temporary easements stated separately; the easement area shown in either square feet or acres depending on size;
- Show existing encroachments to proposed easements; and
- Comply with Title 865 IAC 1-12-25.
- .dwg and or shape file is required for all acquired permanent easements

4.2.7.2 Release of Easement

The EWSU will determine if it is necessary to release an existing easement. The EWSU will handle the paperwork involved with releasing an easement.

4.2.8 Easements on Railroad Rights-of-Way

Whenever possible, utilities shall avoid crossing underneath railroad tracks or into railroad rights-of-way.

4.2.9 Easement Encroachments

An encroachment into an easement is an intrusion onto an easement by a building or other improvement that hinders, jeopardizes, or precludes the intended purpose of the easement. Encroachments into easements shall be clearly identified on the construction plans.

4.2.9.1 Easement Encroachment Agreements

The plat and description(s) required for an easement encroachment agreement shall meet the same requirements as stated for an easement acquisition. In addition, it shall include sufficient information to clearly identify any encroachments on the easement.

4.2.10 Property Acquisition Summary Sheet

Any project that requires three (3) or more easements will require a “Property Acquisition Summary Sheet.” The specific data to be shown on the “Property Acquisition Summary Sheet” is presented in the following paragraphs.

4.2.10.1 Parcel Numbers

Parcel numbers shall be assigned to each parcel of property to be acquired and shown on the plans. “Parcel 1” shall be assigned to the first parcel, and the remaining parcels shall be numbered consecutively from the beginning to the end of the project.

Parcel numbers shall not be changed after submission of the final easement plats. If it is determined that acquisition from any parcel will not be required, that number shall be removed from the plans and the notation "NOT USED" shall be placed in the owner's block on the

"Property Acquisition Summary Sheet."

Parcel numbers for property acquired for temporary easement shall also be numbered consecutively with normal parcel numbers, except that the letter "T" shall precede the number.

4.2.10.2 Owner's Name

The "Property Acquisition Summary Sheet" shall provide the owner's name(s) per the last deed of record.

4.2.10.3 Property Address

The address of the property served shall be shown. If the owner's tax mailing address differs from that of the parcel affected, the owner's tax mailing address shall also be shown.

4.2.10.4 Sheet Number

The sheet number is the number assigned to the plan sheet on which the particular parcel is shown. Some parcels will appear on more than one plan sheet, in which case all sheet numbers shall be included.

4.2.10.5 Source of Title

This column shall show the Vanderburgh County Recorder's Office document number or deed book and page number of the parcel or such other evidence of title information as may be available.

4.2.10.6 Total Area of Tract

The total area of the tract from which an easement is being obtained shall be shown in either acres or square feet in the appropriate column. In general, the area of subdivision tracts shall be shown in square feet, while the area of larger tracts, generally more than an acre, shall be shown in acres.

4.2.10.7 Area of Easements

The area required for perpetual easement shall be shown in square feet or acres in the column designated "Sewer and Drainage Easement." The area required for temporary construction easement shall be shown in square feet or acres in the designated column. Areas shall be shown to the nearest square foot or one-hundredth of an acre as appropriate.

4.2.10.8 Remarks

Additional comments shall be placed in the remarks column of the "Property Acquisition Summary Sheet."

4.2.10.9 Easement Document Number

The EWSU will place the Vanderburgh County Recorder's Office document number of the recorded easement in the last column of the "Property Acquisition Summary Sheet."

4.3 Final Record Drawings

4.3.1 Purpose

This chapter establishes the procedures for Record Drawings so that final drawings correctly depict the facilities as constructed.

4.3.2 Documentation and Approval Process

A record of all Work from the construction drawings will be made upon completion of the project to generate Record Documents. Record Drawings are generated by drawing a line through the original design information and adding the corrected data to the original plans using red ink. Therefore, the Record Drawings shall depict the proposed information and the constructed information, which shall include, but not be limited to, such features as elevations, topographical information, new drawings added to the original plan set, and new and revised calculations based upon altered site conditions.

The developer or their engineer shall prepare record drawings. Based on EWSU review, the plans will either be accepted as Record Drawings or rejected and the developer will be required to resubmit the record drawings.

Record Drawings shall be submitted to the EWSU as .pdfs and .dwg format

4.3.3 Drawing Information

Where constructed information differs from the approved drawings, a line will be marked through the proposed information, clearly label the corrected information near the crossed-out proposed data. Original information shall under no circumstances be erased from the original drawing. A check mark should be placed beside the original plan information that has been verified to be correct as constructed.

All constructed Work will be shown and clouded, preferably in red. Original construction drawing information shall under no circumstances be erased. Record Work shall be noted as follows:

- Where constructed Work differs from the approved drawings, a line will be marked through the original approved drawing information, the recorded Work shall appear adjacent to the crossed-out original approved drawing information, and a cloud placed around the recorded Work information.
- Where constructed Work matches approved drawings, the recorded information will appear adjacent to the original approved drawing information and have a cloud placed around it.

4.3.4 Drawing Requirements

4.3.4.1 Survey Datum:

- Horizontal control shall be referenced to the North American Datum 1983 (NAD83) Indiana State Plane Coordinate System, West Zone, subject to change to INGS per INDOT.
- Vertical control shall be referenced to the National Geodetic Vertical Datum (latest publication and update).

4.3.4.2 Survey Accuracy:

- For hard structures, including concrete overflow swales, horizontal measurements and vertical elevations shall be recorded to 0.01 ft., with accuracy to 0.1 ft.
- For earthen structures, horizontal measurements and vertical elevations shall be recorded to 0.1 ft., with accuracy to 0.5 ft.

4.3.4.3 Record Drawings

The following construction items, at a minimum, should be included in the Record Drawings:

4.3.4.3.1 Alignment

Horizontal location shall be noted for features including but not limited to:

- Manholes
- Cleanouts
- Catch basins or surface inlets
- Headwalls
- Retaining walls
- Slope protection
- Channel linings
- Water main and appurtenances
- Miscellaneous structures
- Storm water basins
- Swales and ditches

4.3.4.3.2 Elevation

Elevations shall be noted for features including but not limited to:

- Inverts of overflows
- Rims
- Surface inlet grate rims and top of curb
- Flow lines
- Structures (all pipe elevations)
- Outlets and spillways

4.3.4.3.3 Pipe Characteristics

- Pipe sizes

- Lengths
- Slopes
- angles

4.3.4.3.4 Materials

Materials for all Work shall be included on record drawings.

4.3.4.3.5 General Record Drawing Requirements

In general, the following shall apply:

- The land surveyor or engineer shall seal and sign ALL SHEETS.
- Any unverified data shall show +/- thereby indicating the information has not been verified.
- The Record Drawing shall be clearly dated.

4.3.4.3.6 Data Tables for GIS

For all projects, data tables shall be submitted to the EWSU as part of the record drawing process for the purposes of transferring information from the plans to the GIS system. Location and type information shall be provided for each appurtenance. Sample information required is as follows:

Water Project:

Project Number
Structure ID Number
Feature Type (Gate Valve, Corp Valve, Stop Valve, Hydrant, Air Release, Anchor Coupling, Tee, Saddle, Tap)
Feature Size
Make/Model
Northing
Easting
Install Date

Sanitary Sewer Project:

Manholes:

Project Number
Manhole ID
Rim Elevation
Material
Manhole Diameter
Access Diameter
Northing
Easting
Invert Elevation
Install Date

Pipes:

Pipe ID Number
Pipe Length
Pipe Material
Pipe Cross Section Shape
Pipe Diameter
Pipe Horizontal Dimension
Pipe Vertical Dimension
Invert Elevation Upstream
Invert Elevation Downstream
Upstream Manhole ID
Downstream Manhole ID
Date Installed

4.4 Sanitary Sewer Design

4.4.1 Introduction

4.4.1.1 Purpose

The purpose of these design standards is to create guide for design of all sanitary sewer systems that will be owned, maintained or operated by the EWSU. These standards are a supplement to the exercise of sound engineering and construction practice required of the registered engineer who prepares the project drawings and specifications and the contractor who constructs them.

This design guide is intended to provide direction for sanitary sewer engineers to ensure the following criteria:

- Protection of the health, welfare, and property of those residents within the EWSU service area
- Provide satisfactory sanitary sewer services
- Ensure operability and maintainability
- Ensure Environmental Protection
- Ensure all local, state and federal laws are met

4.4.1.2 Applicability

Any sanitary sewer system that is currently owned and operated by the EWSU along with any sanitary sewer system where the EWSU will assume ownership is required to meet the standards set forth in this manual. These requirements apply to sanitary sewer mains, laterals, lift stations, low pressure systems, etc.

For private sanitary systems, which are wholly owned, operated and maintained by a private entity, this manual constitutes best management practices. Incorporation of these standards is required.

4.4.1.3 Variances

Variance from these Standards may be granted under unusual and/or specific conditions. Refer to Section 1.9 for the variance procedures and requirements.

4.4.1.4 Ownership

The EWSU owns, operates and maintains the sanitary sewer collection system which includes; sanitary and combined sewers, manholes, lift stations, force mains, and various other sanitary sewer facilities.

Property owners own and maintain their laterals, cleanouts, grease interceptors, sand/oil separators and grinder lift stations and appurtenances unless otherwise agreed upon.

4.4.1.5 Organization of Sanitary Standards

The Standards contain the process, procedures and technical requirements needed to comply with City of Evansville sanitary sewer regulations. Chapter 1 – Section 4 outlines the minimum requirements for the submittal, approval, and acceptance of sanitary sewer system work.

The remaining chapters are dedicated to key sanitary sewer topics. Each chapter contains technical requirements including, but not limited to:

- Allowable design approaches (methods, equations)
- Minimum allowable sizing
- Implementation limitations
- Criteria for submittal
- Minimum geometry requirements

4.4.1.6 Compliance with other Standards

Compliance with these standards does not eliminate the need to comply with other applicable City, County, State and Federal ordinances and regulations. These standards are intended to supplement other guides and manuals produced by the City of Evansville as well as other agencies. Other regulations and resources include, but are not limited to:

- City of Evansville Code of Ordinances
- Evansville Water and Sewer Utility General Rules and Regulations
- Evansville Water and Sewer Utility Green Infrastructure Policy
- Indiana Department of Environmental Management (IDEM) Regulations including Title 327 of the Indiana Administrative Code (327 IAC)
- Great Lakes-Upper Mississippi River Board of State Public Health and Environmental Managers, Recommended Standards for Wastewater Facilities, latest edition. (Also referred to as Ten State Standards for Wastewater Facilities)
- Great Lakes-Upper Mississippi River Board of State Public Health and Environmental Managers, Recommended Standards for Water Works, latest edition. (Also referred to as Ten State Standards for Water Works)
- Indiana Plumbing Code of Indiana Administrative Code (675 IAC 16)
- Indiana Department of Natural Resources (IDNR) Storm Water Quality Manual

- Indiana Department of Transportation (INDOT) Standard Specifications, latest edition
- Indiana Manual on Uniform Traffic Control Devices (IMUTCD), latest edition
- American Association of State Highway and Transportation Officials (AASHTO) A Policy on Geometric Design of Highway and Streets, latest edition
- American Association of State Highway and Transportation Officials (AASHTO) Roadside Design Guide, latest edition

Other submission and approval requirements may include preliminary and final subdivision plats, permits (IDEM or City issued) for sanitary facilities construction, and building and zoning permits; construction inspections; appeals; and similar matters.

The provisions of this document shall be deemed as additional requirements to minimum standards required by other applicable ordinances and standards. In the case of conflicting requirements, the most restrictive shall apply.

4.4.2 Sanitary Sewer Mains

4.4.2.1 Purpose

The purpose of this section is to set forth the design criteria's minimum standards required for projects within the EWSU service area. If for any reason this minimum set of criteria cannot be met, a variance must be approved prior to commencement. Variance procedures can be found in Chapter 1, Section 3.

The following basic elements of design will be covered in this chapter:

- General Improvement Location Criteria
- Horizontal Alignment Criteria
- Vertical Alignment Criteria
- Cleanouts
- Manholes
- Pipe Material
- Pipe Bedding
- Pipe Backfilling
- Pipe Installation
- Design Flow
- Hydraulic Design Criteria
- Downstream Capacity Evaluation
- Pipe Criteria

- Siphons
- Connections of New Sewers to Existing Sewers
- Wye and Lateral Installation

4.4.2.2 General Improvement Location Criteria

This section is intended to provide a general listing of design criteria items that must be considered when developing the proposed sewer alignment. The following list is not intended to be all inclusive.

- Use of existing rights-of-way and/or City Utility easements whenever possible.
- Thoroughly evaluate service needs of both present service area and future service needs.
- Serve entire tributary area in the most efficient way possible.
- Elevation requirements to provide service, with consideration that service to basements may not be an option due to depth, constructability and cost.
- Existing locations of underground and overhead utilities, roadways and railroads.
- Proposed utilities such as sewer, storm water and water facilities.
- Environmentally sensitive areas including creeks, rivers, wetlands, trees, protected habitats, etc.
- Easement requirements, property values, and potential damages to all affected properties.
- Potential development and utility or street extensions into adjacent areas.
- 100-year flood elevations and regulatory floodways.
- Continuity with adjacent infrastructure.
- Maintenance of traffic during construction.
- Subsurface conditions: soils, rock, ground water, other conditions detrimental to construction.
- Access conditions for maintenance.

4.4.2.3 Horizontal Alignment Criteria

Associated Details:

Detail WW-12 – Proposed Sanitary Sewer and Existing Water Line Crossing

In general, sanitary sewers should be located on the opposite side of the street from the water main. Every effort should be made to locate the sewer outside of the pavement, but within existing or proposed right-of-way.

4.4.2.3.1 Placement in Existing Right-of-Way

For sanitary sewers located within existing or proposed street right-of-way, the preferred placement should be as generally defined to allow the following:

- The existence of curbs or proposed curbs and gutter should be taken into account when evaluating the benefit of reducing the number of manholes in curve streets
- In areas with concrete pavement, consider placing the sewer such that one edge of the pavement to be removed coincides with existing construction joints
- Manhole structures shall be either completely outside the pavement or completely within the pavement.

4.4.2.3.2 Placement Outside of Existing Right-of-Way

Where sewers cannot be placed within right-of-way, easements shall be procured. For a list of the easement requirements, see Chapter 1, Section 7 - Easements.

Minimum Horizontal Separation from Water Mains

- A ten (10) foot horizontal distance, measured from the outside edge of the sanitary sewer to the outside edge of the water main, shall be maintained between sanitary sewer and existing or proposed water main.
- Installation of the sanitary sewer closer to the water main **MAY** be approved by variance if:
 - The sanitary sewers meet all water main pressure testing requirements described in 327 IAC 8-3.2.17(a).
 - The sewer shall be constructed of PVC SDR-21 or PVC C900/905.
 - The sanitary sewers and water mains are not in contact.
 - Any sanitary sewer joints are a compression type joint that are placed equidistantly from the water main.
 - The sanitary sewer and water main are laid on separate trench shelves.
- Sanitary manholes shall be separated from water mains by a minimum of 8 feet, measured from the outside edge of the manhole to the outside edge of the water main.

4.4.2.3.3 Rear Lot Alignment

In certain situations or circumstances, rear lot sanitary sewer alignment may be considered. In the event that a rear lot alignment is utilized, a utility easement is required and the sanitary sewer shall not be placed within drainage swales.

4.4.2.3.4 Minimum Distance from Structures

- Where sewer depth is ten (10) feet or less, measured from surface to the invert elevation or manhole base, sanitary sewer mains and manholes shall be located a minimum of ten (10) feet horizontally from any part of a building structure or its foundation.
- For sewer depths greater than ten (10) feet, this minimum distance shall be fifteen (15) feet.

4.4.2.3.5 Location in Relation to Streams and Waterways

Sanitary sewers shall be separated from existing or proposed water bodies by ten (10) feet horizontally measured from the outside edge of the sanitary sewer to the edge of the water line at normal pool elevation.

4.4.2.3.6 Location in Relation to Public Water Supply Wells

Sanitary sewers shall not be located within the isolation area of a public drinking water system well unless the following criteria are met:

- The sanitary sewer must be constructed of pressure rated pipe in conformance with 327 IAC 8-3.2-8.
- The sanitary sewer must meet all pressure testing requirements detailed in 327 IAC 8-3.2-17(a).
- The sanitary sewer is located no closer than 50 feet from the public drinking water well, measured from the outside edge of the drinking water well casing to the outside edge of the sanitary sewer.
- Sanitary sewer manholes shall not be located within the isolation area of the public drinking water well.

4.4.2.4 Vertical Alignment Criteria

Associated Details:

Detail WW-12 – Proposed Sanitary Sewer and Existing Water Line Crossing

4.4.2.4.1 Sanitary Sewer Depths

- Except as specified herein, sanitary sewers shall have a minimum cover of three (3) feet as measured from the top of pipe.
- Basement elevations shall be considered. Basement plumbing shall be lifted up by sump or sewage pumps.
- Where the building level to be served by gravity sanitary sewer is less than one (1) foot above the top of the manhole casting elevation of the first upstream manhole on the public sewer to which the connection is made, backflow prevention shall be included in the design to prevent sanitary sewer backups.

- The sanitary sewer elevation necessary to serve the entire tributary area shall be considered when designing a sanitary sewer. This design shall include areas beyond the boundary of a design section.

4.4.2.4.2 Minimum Vertical Separation from Water Mains (Crossings)

- A minimum vertical separation of 18 inches measured vertically from the outside edge of the sanitary sewer to the outside edge of the water shall be maintained per 327 IAC 3-6-9 Separation of Collection Systems from Water Mains and Drinking Water Wells. This separation requirement shall be the case whether the water main is above or below the sanitary sewer main.
- The crossing point shall be aligned such that the sewer joint is as far as possible from the water main joint.
- The crossing shall be made at a minimum angle of 45 degrees, measured from the center lines of the sanitary sewer and water mains.
- The vertical clearance requirement and the minimum angle requirement must be maintained for a distance of 10 feet on each side of the crossing point.
- If it is not possible to maintain an 18 inch vertical separation, installation of the sanitary sewer closer to the water main **MAY** be approved by variance if:
 - The sanitary sewers meet all water main pressure testing requirements as described in 327 IAC 8-3.2-17(a).
 - The sewer is to be constructed of PVC C900/905 or PVC SDR-21 material.
 - The sanitary sewers and water mains are not in contact.
 - Any sanitary sewer joints are a compression type joint that are placed equidistantly from the water main.
 - Every effort shall be made to construct the sanitary sewer below the water main. The sewer and water mains must be constructed on separate trench shelves.

4.4.2.4.3 Stream and Waterway Crossings

Sanitary sewers located under surface water bodies shall meet the following and comply with 327 IAC 3-6-10 Collection Systems near Surface Water Bodies:

- Sanitary sewers located under surface water bodies shall be constructed of ductile iron pipe or PVC having an SDR of 21 and in conformance with ASTM D2241-96b, with mechanical joints rated to two hundred (200) psi and backfilled with crushed limestone or coarse aggregate.
- Maintain the following cover requirements:

- In paved stream channels, the top of the sanitary sewer must be below the bottom of the paved channel
 - A minimum cover of one (1) foot must be maintained when constructed in rock.
 - A minimum cover of three (3) feet must be maintained in all other crossing situations. In major stream crossings, more than three (3) feet of cover may be required.
- Cross perpendicular to the stream flow.
 - Have no change in grade.

Construction methods shall be specified that will minimize siltation and erosion. Minimum disruption to existing trees and vegetation shall be specified. All temporary and permanent erosion control shall take place immediately upon completion of construction.

4.4.2.4.4 Aerial Crossings

Aerial crossings of surface waterways are discouraged. If an aerial crossing must be constructed, the following design criteria must be addressed:

- Each joint must be supported and anchored.
- Precautions against freezing must be specified such as pipe insulation or increased slope.
- Expansion joints must be provided between above ground and below ground sewers.
- The sanitary sewer pipe must be accessible for repair or replacement.
- The impact of damage from flood waters and debris must be addressed.

4.4.2.5 Cleanouts

Cleanouts are not permitted on a sanitary sewer main. At the end of a run of a sanitary sewer main or a sanitary sewer extension shall be an approved manhole.

4.4.2.6 Manholes

Associated Details:

Detail WW-01 – Standard Precast 48” Sanitary Manhole

Detail WW-02 – Standard Precast 60” Sanitary Manhole

Detail WW-03 – Standard Precast 72” Sanitary Manhole

Detail WW-04 – Precast External Drop Manhole

Detail WW-05 – Standard Manhole Backfill

Detail WW-06 – Standard Manhole Benches and Channels

Detail WW-07 – Standard Casting Adjustment and Grade Ring

Detail WW-08 – Stub-Out at Manhole

Detail WW-09 – Internal Drop Connection to Existing Manhole

Detail WW-10 – New Pipe Connection to Existing Manhole

Detail WW-11 – New Manhole on Existing Pipe

Detail WW-25 – Stainless Steel Adjustable Clamping Bracket

4.4.2.6.1 General Notes

- No lateral or building connections shall be allowed to be connected to a manhole structure.
- Cleanouts cannot be used in lieu of manholes on EWSU owned, operated or maintained systems.
- Manholes shall be pre-cast concrete.

4.4.2.6.2 Manhole Location

Manholes shall be placed at the following locations:

- End of sanitary sewer lines
- Changes in the slope of the pipe (a single manhole may not be used at a high point in a sewer line. Two manholes must be constructed, one for the upstream terminus of each segment)
- Changes in the alignment of the pipe
- Changes in the size of the pipe
- Changes in pipe materials
- Sanitary sewer junctions
- Where dictated by the following maximum spacing requirements:
 - Four hundred (400) feet for sanitary sewers less than fifteen (15) inches in diameter
 - Five hundred (500) feet for sanitary sewers equal to or greater than fifteen (15) inches but less than thirty (30) inches in diameter
 - Six hundred (600) feet for sanitary sewers equal to or greater than thirty (30) inches in diameter

4.4.2.6.3 Manhole Materials

Following is a list of manhole materials that have been approved for use on all sanitary sewer projects where the EWSU will accept, operate or maintain the system. Approved manhole materials are listed below with their associated ASTM designation.

Reinforced Concrete Manhole Sections

- 48-inch diameter with non-concentric cones
- Constructed per ASTM C478-79
- All pre-cast concrete shall contain waterproofing additive Xypex or equal
- All pre-cast concrete for force main receiving manholes and all new manholes within 500 feet upstream or downstream of the receiving manhole shall contain anti-corrosion additive, Conshield or equal

Reinforced Concrete Precast Manhole Sections Base Sections

- 48-inch diameter with preformed butyl mastic joints per Detail WW-01

Manhole Sizes, Dimensions and Grades

- Changes in the direction of flow (the internal angle between two pipes) of less than 90 degrees are not allowed due to the hydraulic losses.
- The minimum size manhole is 48 inches.
- For access to be provided, a minimum of a 24 inch opening is required.

To protect against ponding, manholes shall be designed and constructed to provide positive drainage away from the top of casting as follows:

- Paved or stone areas – Top of casting shall be flush with finished grade.
- Unpaved areas – Top of casting shall be a minimum of two (2) inches above finished grade.

To minimize the potential for inflow and infiltration (I/I), manholes shall not be designed or installed in the following locations:

- Swales or ditches
- Roadside gutters
- Inverted crowns of streets
- Low points of paved or unpaved areas
- Adjacent to storm water inlets
- Any drainage paths not mentioned above

Per 327 IAC 3-6-16, watertight manholes and covers shall be used in all areas where manhole tops are:

- Subject to flooding by street run-off or high water
- Located in a floodway
- Located in a floodplain

4.4.2.6.4 Manhole Castings

For detailed information regarding sanitary sewer manhole castings, see Detail WW-01.

Frame and Cover

- Heavy duty lids in pavement
- Medium duty lids outside of pavement
- Lids to be stamped "SANITARY SEWER"
- Lids to be self-sealing
- Machined bearing surface type with concealed lift holes
- Conform to ASTM A-48, latest edition, Class 35
- Twenty-four (24) inch opening

Lid Gasket Material

- Natural rubber in the polyisoprene chemical group
- ¼ inch diameter formed to the proper diameter
- Conform to ASTM D2000 and ASE J200
- Pressed into a machined groove
- Minimum tensile strength of 2640 psi
- Hardness of 40 durometer
- Original elongation percentages of 575

Casting Adjustments

- Minimum thickness of a riser ring is three (3) inches
- Total number of riser rings shall not exceed two (2).
- External wrap shall be provided on new manholes ASTM C-877
- For watertight manholes, a cast-in-place section is required in lieu of riser rings

4.4.2.6.5 Flow Channel

For all manholes where the influent and effluent pipes are of the same diameter, the following criteria shall be used at the invert of the pipes to account for hydraulic losses in the manhole:

- Change in the direction of flow is less than 45 degrees; a 0.10 foot drop shall be used across the manhole.
- Change in the direction of flow is between 45 degrees and 90 degrees; a 0.20 foot drop shall be used across the manhole.
- Change in the direction of flow is greater than 90 degrees are not allowed.

The channel of flow through a manhole shall be made to conform in shape, and slope to that of connecting sewers. The channel walls shall be shaped or formed to the full height of the crown of the outlet sewer so that maintenance, inspection, and flow in the manhole are not obstructed.

A bench shall also be created on each side of the manhole channel when the pipe diameters are less than that of the manhole diameter. The bench shall be sloped at a minimum rate of ½ inch per foot. Drop pipes shall not discharge onto the surface of the bench.

4.4.2.6.6 Buoyancy

Buoyancy shall be analyzed on the manhole structure to determine whether additional methods of restraint are necessary. The following items are not to be used with analyzing the buoyancy of a manhole:

- Mechanical/electrical equipment
- Water weight
- Any temporary loads

Buoyancy force, opposing force and factor of safety shall be computed as follows:

Buoyancy Force = (Displaced Volume) X (Unit Weight of Water)

Opposing Force = Weight of Barrels + Weight of Bottom Slab + Weight of Top Slab + Net Weight of Saturated Soil Over Bottom Slab Extension + Any Additional Constraints (excluding electrical and mechanical components). The unit weight of water is 62.4 lbs./cu.ft.

Factor of Safety = (Opposing Force)/ (Buoyant Force) > 2.0

If the factor of safety is not greater than 2.0, restraint measures shall be employed. The EWSU engineering department shall be consulted in these instances.

4.4.2.6.7 Pipe Connections

Inlet and outlet pipe connections shall be joined to the manhole with a gasketed, flexible, and watertight connection that allows for differential settlement of the pipe and manhole to take place. See Detail WW-10 and WW-11 for manhole connections.

Drop pipes shall be provided for a sanitary sewer entering a manhole at an elevation of twenty-four (24) inches or more above the manhole invert. Where the difference in elevation between the incoming sewer and the manhole invert is less than twenty-four (24) inches, the invert shall be filleted to prevent solids deposition.

Drop pipes should be constructed with an exterior drop connection. Interior drop pipes should only be considered when exterior drop connections are not feasible.

External Drop

- An external, vertical drop shall be provided for any pipe invert entering a manhole at an elevation greater than two (2) feet above the effluent pipe invert.
- The drop shall be concrete precast or concrete encased.
- Refer to Detail WW-04 – External Drop Manhole.

Internal Drop

- An internal vertical drop may be used for connection to an existing manhole that would require a deep excavation to enter the manhole to within two (2) feet above the pipe invert through the manhole.
- Internal drop pipes shall be secured to the interior wall of the manhole with stainless steel straps and provide access for cleaning and maintenance.
- Refer to Detail WW-09 – Internal Drop Connection to Existing Manhole.
- Refer to Detail WW-25 – Inside Drop Stainless Steel Adjustable Clamping Bracket
- An internal drop may require upsizing of the manhole diameter to 60 inch

4.4.2.7 Pipe Material

The purpose of this section is to provide a list of pipe materials that have been approved for use on all sanitary sewer projects where the EWSU will accept, operate or maintain the system. Approved pipe materials are listed below with their associated American Society of Testing Method (ASTM) designation.

4.4.2.7.1 Smooth wall Polyvinyl Chloride (PVC)

- Shall meet or exceed the requirements of SDR-26 pipe
- For use in gravity sewer installations
- Shall have a minimum pipe stiffness of 115 psi
- Pipe sizes 6 inch to 15 inch in diameter shall meet the requirements of the latest ASTM D-3034 Standard
- Shall have a minimum cell classification of 12454 or 12364 per latest ASTM D-1784 Standard

4.4.2.7.2 Polyvinyl Chloride C-900

- Constructed per AWWA Specification C900
- For use in force mains and gravity mains sizes 4-inch through 12-inch
- Pressure class 150, DR18

4.4.2.7.3 Polyvinyl Chloride C-905

- Constructed per AWWA Specification C905
- For use in gravity mains sizes 14-inch and greater
- Dimension ratio DR18

4.4.2.7.4 Vitrified Clay Pipe

- Shall meet or exceed the requirements of ASTM C-700
- Compression joints per ASTM C-425
- For use in gravity mains

4.4.2.8 Pipe Bedding

Associated Details:

Detail WW-13 – Rigid Sanitary Sewer Pipe Bedding and Backfill within 5’ of, or Under Pavement

Detail WW-14 – Rigid Sanitary Sewer Pipe Bedding and Backfill more than 5’ from Pavement

Detail WW-15 – Non-Rigid Sanitary Sewer Pipe Bedding and Backfill within 5’ of, or under Pavement

Detail WW-16 – Non-Rigid Sanitary Sewer Pipe Bedding and Backfill more than 5’ from Pavement

4.4.2.8.1 Terms

Pipe Bedding	The area used for support directly under the pipe, extending the full width of the trench.
Haunch	The area from the top of the bedding to the springline of the pipe extending the full width of the trench.
Springline	The horizontal centerline of the pipe.
Initial Backfill	The area from the springline to twelve (12) inches above the crown (top) of the pipe.
Pipe Embedment	The total area that includes the bedding, haunch and initial backfill.
Final Backfill	Beginning twelve (12) inches above the crown up to the bottom of the surface

restoration (generally topsoil, various pavements, sidewalks, etc.).

Contractor shall not place pipe embedment materials by methods that will damage or disturb the pipe. Compaction equipment shall not come into contact with pipe that could result in damage. Before using heavy compaction or construction equipment directly over the pipe, ensure sufficient backfill is installed over the pipe to prevent damage or excessive deflection.

4.4.2.8.2 Rigid Pipe Embedment

For the purpose of this specification, rigid pipe shall include those made of vitrified clay pipe and other materials determined by the Sewer Utility.

All rigid pipe shall be laid to the engineer's specified lines and grades unless otherwise directed by the EWSU. All rigid pipe shall be bedded and haunched with the following:

- Manufactured, clean, angular, granular material such as crushed stone,
- #5 or #8 stone per INDOT Standard Specifications
- The pipe bedding shall be compacted and placed on a flat trench bottom
- Bedding shall extend a minimum of six (6) inches or one half (1/2) the outside pipe diameter to a maximum of eight (8) inches below the pipe
- The same granular material shall be used to haunch on both sides of the pipe
- All materials shall be placed in the trench in no more than six (6) inch layers
- Each layer, shall be leveled and evenly distributed on both sides of the pipe so as not to disturb, displace or damage the pipe and shall be thoroughly compacted
- Compaction of the crushed stone shall be accomplished by hand or mechanical tamping or by "walking" the material into place

In areas that are outside the influence of traffic or determined by the EWSU, refer to Detail WW-14 noting that:

- Initial backfill (from the haunch to twelve (12) inches above the pipe), may be excavated trench in-situ soil materials
- Must be compacted and placed in six (6) inch lifts
- Excavated soil materials for usage as backfill shall be free from rocks (three inches in diameter or greater) concrete, roots, stumps, rubbish, frozen materials and other similar articles whose presence in the backfill would cause excessive settlement.
- Excavated in-situ soil materials shall not include topsoil, peat or non-compactable materials

For areas that are within influence of traffic or determined by the EWSU, refer to WW-15 and follow the guidelines and procedures outlined in Section I. Pipe Backfilling.

4.4.2.8.3 Non-Rigid Pipe Embedment

For the purpose of this specification, non-rigid pipe shall include those made of PVC, Ductile Iron and other materials determined by the Sewer Utility.

All non-rigid pipe shall be laid to the engineer's specified lines and grades unless otherwise directed by the EWSU. All non-rigid pipe shall be bedded, haunched with the following:

- Initially backfilled with manufactured, clean, angular, granular material such as crushed stone, with gradation between ¼" to 1-½" (6 to 40 mm) in size
- Pipe bedding shall be compacted and placed on a flat trench bottom
- Pipe bedding shall extend a minimum of six (6) inches or one half (1/2) the outside pipe diameter to a maximum of eight (8) inches below the pipe
- This same granular material shall be used to haunch and for initial backfill on both sides of the pipe and full trench width.
- All materials shall be placed in the trench in no more than six (6) inch layers
- Each layer, shall be leveled and evenly distributed on both sides of the pipe so as not to disturb, displace or damage the pipe
- Each layer shall be thoroughly compacted
- Compaction of the crushed stone shall be accomplished by hand tamping, mechanical tamping or by "walking" the material into place
- Final backfilling shall follow the guidelines and procedures outlined in Section I. Pipe Backfilling

Special bedding, foundation or haunching requirements may be requested by the EWSU to insure adequate pipe support for various soil conditions.

4.4.2.9 Pipe Backfilling

Associated Details:

Detail WW-13 – Rigid Sanitary Sewer Pipe Bedding and Backfill within 5' of, or Under Pavement

Detail WW-14 – Rigid Sanitary Sewer Pipe Bedding and Backfill more than 5' from Pavement

Detail WW-15 – Non-Rigid Sanitary Sewer Pipe Bedding and Backfill within 5' of, or under Pavement

Detail WW-16 – Non-Rigid Sanitary Sewer Pipe Bedding and Backfill more than 5' from Pavement

4.4.2.9.1 Terms:

Pipe Bedding	The area used for support directly under the pipe, extending the full width of the trench.
Haunch	The area from the top of the bedding to the springline of the pipe extending the full width of the trench.
Springline	The horizontal centerline of the pipe.
Initial Backfill	The area from the springline to twelve (12) inches above the crown (top) of the pipe.
Pipe Embedment	The total area that includes the bedding, haunch and initial backfill.
Final Backfill	Beginning twelve (12) inches above the crown up to the bottom of the surface restoration (generally topsoil, various pavements, sidewalks, etc.).

All sanitary sewer main pipe should be backfilled the same day as installed. Prior to using heavy compaction or driving construction equipment directly over the newly installed pipe, ensure sufficient backfill is placed over the pipe to prevent damage or excessive deflection.

Compaction testing methods and frequency, where required, shall be at the discretion of the transportation engineer with jurisdiction whether it be the City Engineer, County Engineer, or INDOT.

Final backfill requirements subject to traffic influence, which is generally considered as being an area subject to routine vehicle usage and as determined by the EWSU, such as roadways, alleys or driveways shall be per the Latest Indiana Department of Transportation (INDOT) Standard and Specification (SS) Section 211, County Engineer, or City Engineer requirements where applicable. This traffic influence is generally considered by the following criteria:

- The area within five (5) feet of the edge of traffic (including shoulders) as measured from the outer edge of the pipe trench closest to the traffic influence edge
- The area also includes areas within a 1:1 traffic influence zone, based on depth and distance, taken from the outer edge of the pipe closest to the traffic influence edge

All backfill placed within traffic influence zones shall conform to the following criteria:

- Installed in lifts not exceeding six (6) inches
- Compacted to 95% maximum dry density in accordance with AASHTO T 99 as specified in INDOT SS Section 203 or as directed by the City Engineering or County Engineering Department.

- Shall consist of manufactured, clean, angular, granular material such as crushed stone, with gradation between ¼" to 1 ½" (6 to 40 mm) in size.

Final backfill requirements, not subject to the influence of traffic as noted above, shall generally be backfilled with acceptable, excavated trench in-situ soil materials in accordance with the following:

- In-situ soil materials shall be placed and compacted in twelve (12) inch lifts and/or mounded to accommodate settlement during project development.
- In-situ soil materials shall be free from rocks (three inches in diameter or greater) concrete, roots, stumps, large amounts of sod or other organic materials, rubbish, frozen materials and other similar articles whose presence in the backfill would cause excessive settlement.
- To allow for settlement, the surface of the trench shall generally be left in a slightly rounded condition.

4.4.2.10 Pipe Installation

The approved pipes shall be installed according to the manufacturers' recommendations. Sewer extensions shall be built meeting the following requirements.

- Built and verified to the approved grade by use of a laser
- Pipe material shall not change as installed from manhole to manhole.
- Pipe grade shall not change as installed from manhole to manhole
- Pipe alignment shall not change as installed from manhole to manhole

4.4.2.10.1 Sanitary Sewer Clearances

With respect to potable water lines, sanitary sewers shall maintain the following separations:

- Ten (10) feet minimum separation requirement of an existing or proposed water main (as measured horizontally from the outside edge of the sanitary sewer to the outside edge of the water main)
- Eighteen (18) inches of vertical clearance (as measured vertically from the outside edge of the sanitary sewer to the outside edge of the water main) - Note that vertical crossings must be at a minimum forty-five (45) degree angle as measured from the centerlines of the sanitary sewer and water main
- No sanitary sewer manhole shall be within eight (8) feet of a water main as measure from the outside edge of the sanitary sewer manhole to the closest outside edge of the water main.

4.4.2.10.2 Depth Restrictions

The minimum cover for sanitary sewer shall be three (3) feet. Determination of maximum depth limitations for the installation of the different, approved pipe materials reserved at this time.

With differing depth ranges, special bedding or foundation requirements may be requested by the EWSU to ensure adequate pipe support for various soil conditions as described in ASTM

F1668-08 X1 - Pipe-Soil Interaction. For pipe material usage exceeding depths not usually experienced by the Utility, supportive data and calculations may be required to ensure long term performance of the pipe.

A solid twelve (12) gauge plastic coated copper tracer wire shall be installed with all PVC force main, access to the wire must be provided at one-thousand (1,000) foot intervals along the length of the main.

4.4.2.11 Design Flow

Sanitary sewers shall be designed to accommodate the peak hourly flow within the sewer system.

Average Daily Flow (ADF)

- The design of all sanitary sewer facilities shall take into account both existing and projected future developments.
- Development Flows: Flows shall be calculated based on 327 IAC 3-6-11 Design Flow Rate Requirements for collection systems and water pollution treatment/control facilities. See Table 2 below for a partial excerpt from 327 IAC 3-6-11.

TABLE 4-1 WASTEWATER DESIGN FLOWS

DEVELOPMENT	AVERAGE GALLONS PER UNIT/DAY
Airport	3 per Passenger plus 20 per Employee
Apartment or Condominium	
a. One-bedroom	200 per dwelling
b. Two-bedroom	300 per dwelling
c. Three-bedroom	350 per dwelling
Church	
a. With kitchen	5 per Sanctuary Seat
b. Without kitchen	3 per Sanctuary Seat
Factory	
a. With showers	35 per employee
b. Without showers	20 per employee
Food Service Operations	
a. Restaurant (not 24-hour)	35 per Seat
b. Restaurant (24-hour)	50 per Seat
c. Tavern/Bar	35 per Seat
Hospital/ Medical Facilities	200 per Bed
Hotels/ Motels	100 per Room
Laundromat	100 per Machine
Mobile Home Park	200 per Lot
Nursing Home	100 per Bed
Office Building	20 per Employee
School	
a. Elementary	15 per Student

DEVELOPMENT	AVERAGE GALLONS PER UNIT/DAY
b. Secondary	25 per Student
Shopping Center	0.1 per square foot of floor space plus 20 per Employee
Single Family Dwelling	310 per dwelling
Two Family Dwelling (Duplex)	620 per dwelling
FUTURE LAND USE	
Fill-in Residential	900 per Acre (3 homes/acre)
Subdivision Residential	900 per Acre (3 homes/acre)
Industrial	850 per Acre
Commercial	600 per Acre

Peak Design Flow

- The peaking factor used to multiply by the average daily flow shall be 4.
- When actual flow metering data is available, the monitored flows may be used for design.

4.4.2.12 Hydraulic Design Criteria

Manning’s Equation shall be used to determine the required pipe size and slope. The design shall account for full flow, saturated conditions along with the following characteristics.

- Manning’s Equation $Q = \frac{1.49}{n} (A) (R)^{\frac{2}{3}} \sqrt{S}$
- Roughness Coefficient, n = 0.013
- Minimum Pipe Size, D = 8 inches
- Minimum Pipe Velocity, V = 2.0 feet/second
- Maximum Pipe Velocity, V = 15 feet/second
- Maximum Pipe Slope, S = 3.0%
- Minimum Allowable slopes – See 4-2

TABLE 4-2 MINIMUM ALLOWABLE SLOPES

MANNING’S “N” = 0.013			
Pipe Diameter (inches)	Slope		Velocity Full (ft/sec)
	(ft/ft)	Percent	
8	0.0040	0.40	2.2
10	0.0028	0.28	2.1
12	0.0022	0.22	2.1
15	0.0015	0.15	2.0
18	0.0012	0.12	2.0
21	0.0010	0.10	2.1
24	0.0008	0.08	2.0
27	0.00067	0.067	2.0

MANNING'S "N" = 0.013			
30	0.00058	0.058	2.0
33	0.00052	0.052	2.0
36	0.00046	0.046	2.0
42	0.00037	0.037	2.0
48	0.00069	0.069	3.0
54	0.00059	0.059	3.0
60	0.00051	0.051	3.0
66	0.00040	0.040	3.0
72	0.00036	0.036	3.0
78	0.00033	0.033	3.0
84	0.00026	0.026	3.0
96	0.00026	0.026	3.0
108	0.00026	0.026	3.2
120	0.00026	0.026	3.4
132	0.00026	0.026	3.6
144	0.00026	0.026	3.8

4.4.2.12.1 Changes in Sanitary Sewer Pipe Sizes

Sewer size changes are only allowed at manholes. The energy gradient must be maintained at these changes. An approximate method for achieving this is to place the 0.8 depth point of both sewers at the same elevation. Another alternate method utilized involves matching of pipe crown elevations.

Pipes less than or equal to 24-inch diameter:

- When increasing pipe diameter by six inches (6") or less, crown elevations at the centerline of the manhole shall match.
- When increasing pipe diameter by more than six inches (6"), the springlines of the pipes at the centerline of the manhole shall match.

Pipes Greater than 27-inch (27") Diameter

The junction shall first be designed by matching crowns at the centerline of the manhole. The energy grade line shall then be evaluated in both the upstream and downstream segments. The grade line shall not increase in the downstream segment. If the energy grade line of the downstream segment lies below the energy grade line of the upstream segment, the downstream sewer may be raised by two-thirds of the difference between the upstream and downstream grade lines.

4.4.2.12.2 Minimization of Solids Deposition

The pipe diameter and slope shall be selected to obtain the greatest practical flow velocities to minimize settling problems. Sewers shall not be oversized to allow for construction on a flatter

slope. If the proposed slope is less than the minimum slope of the smallest pipe which could properly accommodate the peak hourly design flow, a variance shall be obtained.

4.4.2.12.3 Hydraulic Computations

All hydraulic calculations shall be submitted to the EWSU for review during project design. In general, the calculations shall include, but not be limited to, the following:

- Service area designation
- Average daily flow
- Peak daily flow
- Identification of any intermediate flows
- Sewer sizing and slope calculations
- Sewer velocity calculations

4.4.2.13 Downstream Capacity Evaluation

With a new development adding additional loads to the existing infrastructure, downstream capacities will need to be evaluated to ensure the receiving sanitary sewers are sized properly to receive the new proposed flows. To evaluate these capacities, the EWSU will rely on the following data/information:

- Existing number of customers connected to existing sewer
- Existing flow monitoring data
- Sanitary sewer studies
- Maintenance records
- Complaint records
- Past and/or proposed Capital Improvement Projects
- Any other information deemed relevant by City Utilities Engineering

4.4.2.13.1 Temporary Flow Monitoring (if necessary)

- The complexity of the downstream system will determine the number of temporary monitors required.
- Temporary Rain Gages – Temporary rain gages shall be installed at or near the temporary flow monitoring site(s) during the flow monitoring period, unless monitors are located nearby.
- Flow Monitoring Data and Format
 - Depth/Velocity Hydrographs
 - Flow Hydrographs

- Scatterplots/Scattergraphs
- Any other monitoring data deemed necessary by the EWSU

4.4.2.13.2 Hydraulic Modeling

Extension of the existing sanitary sewer collection system model to the point of connection of the proposed development may be utilized in gathering information and data.

An evaluation of one or more lift station systems may be required. The evaluation may include the following systems:

- Hydraulic
- Electrical
- Mechanical
- Instrumentation & Control
- Any other systems deemed necessary by the EWSU

If downstream capacity is not available for the proposed flow from the serviced area, the following alternatives **MAY** be considered to increase the capacity.

- Increasing capacity in the system (increase existing pipe sizes)
- Removing sufficient volume of Infiltration/Inflow (I/I)
- Connecting to an alternate point within the sanitary or combined sewer system. A downstream analysis at the alternate point of the system may be required.

4.4.2.14 Pipe Criteria

4.4.2.14.1 Sewer Pipe Design

- The minimum allowable inside diameter for sewer main pipe shall be eight (8) inches and tie into a manhole.
- All sanitary sewers shall be constructed with a straight alignment between manholes.
- Pipe materials shall be in accordance with EWSU Approved Pipe Materials.
- Pipe testing and bedding requirements shall be in accordance with EWSU Standards. If circumstances warrant otherwise, notification of variance is required.
- All sanitary sewers shall be designed to prevent damage from applied loads both during and after construction. Load allowance shall be based upon trench width and depth. In instances in which standard strength pipe is not sufficient, extra strength pipe or special construction methods shall be specified.

4.4.2.14.2 Floatation

All sewers and sewer structures to be constructed shall be protected against floatation and excessive pipe deformation in areas where high groundwater conditions exist or flooding of the trench is anticipated.

4.4.2.14.3 Anchors

- Sewers constructed on ground slopes of 20% or greater shall be anchored securely with concrete or other acceptable material.
- All design methods for anchors shall be approved by the EWSU Engineering Department.

4.4.2.14.4 Concrete Encasement

Concrete encasements may be utilized in the following instances:

- When it is necessary to prevent floatation.
- When crossing streams, ditches, existing storm drains, or in railroad or highway rights-of-way.
- Where soil conditions indicate the possibility of heavy erosion.
- In areas where less than the desired cover is provided.

The concrete encasement shall extend a minimum length of two (2) feet beyond the point where a four (4) foot depth of cover is reached or to a point five (5) feet beyond the tops of banks when crossing a ditch or stream.

The encasement of flexible pipes shall not be allowed except when the encasement is completed from structure to structure, unless otherwise recommended by the pipe manufacturer.

4.4.2.14.5 Railroad Crossings

When any railroad is crossed, the specifications and precautionary measures required by the respective railroad officials shall be followed. A copy of the railroad crossing application and proof of approval from the respective railroad entity shall be provided to the EWSU. In the absence of specific railroad requirements, the following general criteria shall apply:

- The following criteria shall apply to instances in which sanitary sewer construction affects railroad rights-of-way and facilities. In certain instances, the requirements of the specific railroad company may be more stringent than these standards. In those instances, the more stringent standard shall apply.
- Sanitary sewers shall cross tracks at an angle as close as possible to 90 degrees (90°). The crossing angle shall never be less than 45 degrees (45°)
- Sanitary sewer mains crossing beneath railroad tracks shall be constructed in jack and bored casings.

- Casing pipe under railroad tracks and across railroad rights-of-way shall extend to a point a minimum distance of twenty-five (25) feet from the centerline of the outside track or to the right-of-way line, whichever occurs first and a minimum of five (5) feet beyond the top of ditch bank within the railroad right-of-way.
- Sanitary sewer mains laid longitudinally along railroad rights-of-way shall be located as far as practical from the tracks. If the sewer is located within twenty-five (25) feet of the centerline of any track, the sewer shall be encased or shall be of a special design as approved by the EWSU.
- Casings under tracks and across railroad rights-of-way shall be a minimum of four (4) feet deep as measured from the bottom of the track to the top of the casing pipe.

4.4.2.14.6 Highway Crossings

When any highway is crossed, the specifications and precautionary measures required by the respective highway officials shall be followed. A copy of the highway crossing application and proof of approval from the respective highway entity shall be provided. In the absence of specific highway requirements, the following general criteria shall apply:

- Sanitary sewers shall cross the roadway at an angle as close as possible to 90 degrees (90°). The crossing angle shall never be less than 45 degrees (45°).
- Sanitary sewer mains crossing beneath the highway shall be constructed in bored and jacked casings.
- Sewers shall not be placed under roadway bridges where the possibility of restricting the required waterway area or where a possibility of compromising the structural integrity of bridge foundations exists.
- Borings under highways shall have a minimum depth of cover of three (3) feet as measured from the surface elevation to the top of the casing. The top of the casing shall not be above the invert of existing or proposed ditches.
- Borings under highways shall extend a minimum of ten (10) feet (measured perpendicularly) outside the outer edge of existing pavement or to the toe of slope when the roadway is on fill and the toe of slope exceeds the ten (10) foot outside of pavement requirement.
- Sanitary sewer mains laid longitudinally along highway rights-of-way shall be located a sufficient distance outside of the existing edge of pavement to ensure worker and motorist safety during construction.
- Sanitary sewer mains laid outside of pavement but inside of roadway right-of-way shall have a minimum depth of cover of three (3) feet.

In certain instances, the requirements of specific highway authorities may be more stringent than these standards. In those instances, the more stringent standard shall be utilized.

4.4.2.14.7 Jack and Boring – Casing Pipe

Casing pipe shall be bare wall steel pipe with a minimum yield strength of 35,000 psi. The inside diameter of the casing pipe shall be a minimum of four inches (4”) greater than the outside diameter of the carrier pipe joints or couplings for carrier pipe less than six inches (6”) in diameter and at least six inches (6”) greater than the outside diameter of the carrier pipe joints or couplings for carrier pipe six inches (6”) in diameter and greater. The casing pipe shall have a minimum wall thickness as required by 4-3 below:

TABLE 4-3 CASING PIPE MINIMUM THICKNESS

CASING OUTSIDE DIAMETER (INCHES)	CASING WALL THICKNESS HIGHWAY CROSSINGS (INCHES)	CASING WALL THICKNESS RAILROAD CROSSINGS (INCHES)
8.625	0.250	0.250
10.750	0.250	0.250
12.750	0.250	0.250
14	0.250	0.281
16	0.250	0.281
18	0.250	0.312
20	0.250	0.344
24	0.250	0.406
30	0.375	0.469
36	0.375	0.532
42	0.375	0.563
48	0.500	0.625
54	0.625	0.688
60	0.625	0.750
66	0.625	0.813
72	0.750	0.875

Minimum depth of the casing pipe shall be 54 inches (54”) or as required by the affected highway, railroad, etc.

The EWSU reserves the right to require larger diameter carrier pipes to accommodate additional proposed or future utility lines.

Casing pipe shall have sealed ends to prevent foreign material from entering the therefore protecting both the carrier pipe and the casing pipe

The casing pipe and carrier pipe shall be separated by insulators/spacers. The insulator spacing shall be installed to support the weight of the pipe and its contents.

4.4.2.15 Siphons

Design and construction of inverted siphon structures requires written approval from the EWSU prior to commencement of the design process.

Inverted siphon structures shall have a minimum of two (2) barrels. Minimum allowable barrel diameter shall be eight (8) inches. Design of the structure shall provide sufficient head and appropriate pipe sizes to secure a minimum velocity of 3.0 ft. /sec for average design flows. The structure inlet and outlet shall be designed such that the average design flow is diverted to one siphon barrel, therefore allowing for either barrel to be taken out of service for cleaning and/or repair.

4.4.2.16 Connection of New Sewers to Existing Sewers

Sanitary sewers and force mains shall only be connected to the existing sewer system at manholes. For lateral connections, refer to Chapter 3 Section 3 – Sanitary Sewer Laterals. Sewer lateral connections to existing manholes is not allowed. Rehabilitation may be required and the decision to rehabilitate the mains will be at the discretion of the EWSU. Rehabilitation methods will be determined on a case-by-case basis.

Blind tee connections to existing sewers are prohibited.

If an existing manhole is not available a new manhole shall be installed.

For new construction within the combined sewer system, all new or proposed sanitary and storm sewers shall be separated prior to connecting to the combined sewer system. Each system shall be connected individually to the combined sewer if a separate storm sewer system is not available.

4.4.2.17 Wye and Lateral Installation

Whenever the sanitary sewer is located in street right-of-way, a six-inch lateral shall be extended to the property line of each lot. The location of each wye and the length of six-inch pipe used shall be shown on the as-built drawings. The wye shall be factory-constructed wye with a 45-degree bend pointed in the direction of flow in the main sewer. No tee shall be angled at any less than a 50-degree angle with the vertical to eliminate vertical loading of the pipe and wye connection during backfilling. The #7 stone shall be placed under and around the six- inch pipe section of each wye.

Whenever the sanitary sewer is located in an easement, the same requirements must be met. A piece of lateral pipe, six feet in length, shall be stubbed in the easement.

All six-inch laterals shall be sealed with a six-inch cap sealed with glue for plastic pipe. All laterals shall be marked from the lateral end cap to a point (5) five feet above grade with (1") one inch schedule 80 PVC with a (.5") rebar placed inside to protect them from other construction, etc., within the area.

For more information on sanitary sewer laterals, see Chapter 3, Section 3 — Sanitary Sewer Laterals.

4.4.3 Sanitary Sewer Laterals

4.4.3.1 Purpose

The purpose of this section is to set forth the design criteria's minimum standards required for sanitary sewer laterals within the EWSU service area. If for any reason this minimum set of criteria cannot be met, a variance must be approved prior to commencement. Variance procedures can be found in Chapter 1, Section 3.

For the purposes of this manual, sanitary sewer laterals are defined as:

A private sewer that connects a building's plumbing system to the public or private sewer system. A sanitary sewer lateral will typically begin at the outside wall of the building for which the lateral is serving.

All sanitary sewer laterals shall conform to the latest version of the Indiana Plumbing Code (675 IAC 16) and to the standards listed in this section. In the event that there are discrepancies between the two standards, the most restrictive shall reign supreme.

Property abandoned over five (5) years will be treated as if no previous improvements had ever been made.

The following basic elements of design will be covered in this chapter:

- Buildings Serviced
- Sanitary Sewer Lateral Location, Elevation, Length and Spacing
- Sanitary Sewer Lateral Crossing Drainage Ways
- Hydraulic Design
- Sanitary Sewer Lateral Pipe
- Sanitary Sewer Lateral Appurtenances
- Sanitary Sewer Lateral Connections to Main Line Sewers
- Connections Using an Existing Sanitary Sewer Lateral
- Future Connections

4.4.3.2 Prohibited Connections

Evansville Municipal Code 13.05.070 - Storm or Industrial Wastewaters states "No person shall discharge or cause to be discharged any storm water, surface water, ground water, roof runoff, subsurface drainage, cooling water, or unpolluted industrial process waters to any sanitary sewer from any source including, but not limited to, roof leaders, cellar drains, yard drains, area drains or foundation drains."

4.4.3.3 Buildings Serviced

A separate sanitary lateral service connection shall be constructed for each individual building except where one building is constructed in the rear of another if standing on the servicing sanitary sewer main. In scenarios where this is the case, both buildings shall be considered as one with the calculations, sizing and configuration.

4.4.3.4 Gravity Sewer Service

Gravity sanitary sewer lateral connections shall be constructed for homes or buildings where the lowest elevation to have sanitary services is one (1) foot or more above the top of the manhole casting elevation of the first upstream manhole on the sanitary sewer main to which the connection is proposed to be made.

In situations where this one foot distance is not achievable and/or in areas susceptible to back-ups, proper backflow prevention shall be required. If the first upstream manhole is at a higher elevation due to

the natural topography of the area, an alternate method may be proposed by the variance section outlined in Chapter 1 Section 3.

4.4.3.5 Non-Gravity Service

In the situation where gravity flow cannot be achieved with the aforementioned criteria, grey water shall be pumped by an approved means into the sanitary sewer laterals mainline and subsequently discharged into the public sanitary sewer main.

4.4.3.6 Sanitary Sewer Lateral Location, Elevation, and Spacing

Associated Details:

Detail WW-17 – Sanitary Sewer Lateral Connection Layout (Residential)

Detail WW-18 – Sanitary Sewer Lateral Connection Layout (Commercial)

4.4.3.6.1 Sanitary Sewer Lateral Location

- All properties shall be served from the street, ally or easement side of the property.
- A sanitary sewer lateral shall not cross the property line or land lease line of another private owner.
- Sanitary Sewer Laterals shall not be located within ten (10) feet of any existing or proposed water well.
- Where a sanitary sewer lateral location unavoidably lies within fifty (50) feet of a drinking water well, pressure grade pipe material shall be used and comply with 327 IAC 8-3.2-8 Water Main Material per 327 IAC 3-6-9 Separation of collection systems from water mains and drinking water wells.

4.4.3.6.2 Sanitary Sewer Lateral Elevation

Every building to be served by the Sanitary Sewer System shall have its plumbing and building floor elevations designed to prevent property damage caused by municipal backups. The lowest fixture in the house should be one (1) foot higher than the top of the first upstream manhole rim elevation. If not, the plumbing in the basement shall be lifted up by sump pumps or sewage pumps or have backflow prevention installed per Evansville Municipal Code. A developer shall provide for this requirement in selling the lots.

4.4.3.6.3 Sanitary Sewer Lateral Spacing

The minimum horizontal distance between a sanitary sewer lateral and a property line is three (3) feet.

The minimum horizontal distance between adjacent sanitary sewer laterals is six (6) feet.

4.4.3.7 Sanitary Sewer Laterals Crossing Drainage Ways

Sanitary sewer laterals shall be separated from existing or proposed water bodies by a minimum twenty (20) feet, horizontally as measured from the outside edge of the sanitary sewer lateral to the top of the bank.

Sanitary sewer laterals crossing proposed or existing lakes, ponds, and/or retention/detention areas (either wet or dry) are prohibited.

4.4.3.8 Hydraulic Design

Sanitary sewer laterals sized eight (8) inches and smaller shall have a minimum slope of ¼" per foot (2.08%). For those laterals sized larger than eight (8) inches, the requirements for sanitary sewer mains, located in Chapter 3 Section 2 are to be followed.

4.4.3.9 Sanitary Sewer Lateral Pipe

Sanitary Sewer Lateral Pipe Size

- The minimum allowable diameter for laterals shall be six (6) inches.
- Larger pipe sizes for commercial and industrial connections shall be approved on a case-by-case basis.

The minimum pipe depth from the finished grade to the crown of a sanitary sewer lateral shall be three (3) feet.

Pipe materials shall be in kind with the materials used for the receiving sanitary sewer main. This material shall continue, at a minimum, up to the first cleanout located at the property line.

Pipe bedding and backfill requirements shall be in accordance with Chapter 3 Section 2 unless special circumstances warrant otherwise, for which a variance will be required.

All sewer laterals shall be designed to prevent damage from applied loads both during and after construction. Load allowance shall be based upon trench width and depth. In instances which standard strength pipe is not sufficient, extra strength pipe or special construction methods shall be specified. All loading requirements must be taken into account when considering material selection and installation methods.

4.4.3.10 Sanitary Sewer Lateral Appurtenances

Associated Details:

Detail WW-19 – Standard Sanitary Cleanout in Paved Areas

Detail WW-20 – Standard Sanitary Cleanout in Un-Paved Areas

4.4.3.10.1 Cleanouts

- A cleanout shall be provided at the property line to all building structures to determine maintenance responsibilities.
- Cleanouts shall be extended to match grade in paved areas and extended to above grade in non-paved areas.
- Cleanouts shall be spaced a maximum of every one hundred (100) feet.
- Cleanouts shall match the size of the lateral up to a maximum of eight (8) inches.

- The cleanout cover shall be threaded-type, water tight, and capped at all times. Covers within paved areas shall be metallic and able to withstand traffic loads.
- Cleanouts installed under concrete or asphalt pavement shall be extended flush with the pavement and have a concrete collar.

4.4.3.10.2 Fats, Oils, and Grease (FOG) Interceptors and/or Separators

Per Evansville Municipal Code 13.05.090 - Grease, oil or sand traps:

“(A) Any building sewer which will have or has the potential to discharge waste containing grease, oil, sand or similar substances shall have a grease, oil and/or sand trap (“grease trap”) installed. Disposal to the sewers of mineral-based oils and greases is expressly prohibited. Grease traps shall not be required for private living quarters or dwelling units, but are mandatory for all restaurants and/or food preparation services. In no case shall a trap of less than 50 pounds grease retention capacity be installed. Grease traps shall be installed and maintained in such a manner as to provide at all times the effective removal of these substances before discharge to the public sewer. All grease traps shall be of the standard type and capacity which meets City and State requirements and shall be readily and easily accessible for cleaning and inspections. Additives which emulsify or impede the separation of oils and grease shall not be allowed. Where required under this section, the cost of and responsibility for installation and maintenance of the traps shall be the sole responsibility of the utility user.”

“(B) A grease trap must be installed that is of sufficient capacity and design to prevent grease, oil or sand from entering the public sewer. If a previously installed grease trap is replaced or cannot prevent said materials from entering the sewer system, then the replacement grease trap shall meet the requirements of subsection (A) of this section.”

“(C) Grease interceptor cleaning and maintenance shall include pumping the interceptor until empty, and cleaning the side walls, baffle walls and cross-pipes, and inlet and outlet pipes. Decanting, skimming, or back flushing is prohibited. A full pump-out is required. In the event that the grease trap volume is greater than the tank capacity on the vacuum truck, the transporter shall arrange for additional transportation capacity so that the trap is fully evacuated within a 24-hour period.”

4.4.3.10.3 Requirements for Grease Interceptors:

- Must be located outside the building
- If building or facility has one of the following, then a grease interceptor is required:
 - 3- or 4-basin sink
 - Pre-rinse sink
 - Pots & pans sink
 - Work station
 - Soup kettle

- If facility has one of the following, then a grease interceptor is recommended:
 - Floor drains in food prep area
 - Mop sink
- The following CANNOT go through a grease interceptor:
 - Garbage disposal
 - Dishwasher
 - Domestic waste
- The minimum capacity of a grease interceptor is 1,000 gallons.
- Refer to the policy for Design, Installation & Maintenance of FOG Removal Systems on the City Government website, located at:
<http://evansville.in.gov/indes.aspx?page=3629>

4.4.3.10.4 Requirements for Sand/Oil Separators:

- If facility has one of the following, then a sand/oil separator is required:
 - Repair garage with trench or floor drain
 - Car washing facility
 - Trench drains
 - Factories where oily & flammable liquid wastes are produced
 - Hydraulic elevator pits
- Refer to Standard Drawing STR-C for a detail of a 1,000 gallon sand/oil separator.
- For grease interceptors and sand/oil separators, refer to the following standards for more detailed information:
 - International Plumbing Code Section 1003 Interceptors and Separators
 - Uniform Plumbing Code Section 1014 Grease Interceptors and Section 1016 Sand Interceptors
 - IAPMO/ANSI American National Standard for Prefabricated Gravity Grease Interceptors

4.4.3.10.5 Control Manholes

- When required, a control manhole shall be included in the sanitary sewer lateral design.
- If a grease interceptor or sand/oil separator exists or is required, then a control manhole is required.

- If flow from the lateral is expected to 50,000 gpd or greater, then a metered control manhole may be required. This requirement will be determined on a case by case basis.
- Control manholes require the approval of the EWSU.
- For control manholes greater than four (4) feet in depth, manhole steps are permitted.

4.4.3.11 Lateral Connection to Main Line Sewer

Associated Details:

Detail WW-22 – Shallow Sanitary Service Connection

Detail WW-23 – Deep Sanitary Service Connection

Detail WW-24 – Sanitary Service Connection to Existing Pipe

All taps shall use factory wye installed during sanitary sewer main installation where available.

Tap in connections where a factory wye is not available shall be core drilled into the sewer main. The core drill diameter shall be, at a minimum, the same size as the sewer lateral or as required by sewer saddle manufacturer. The main shall be drilled 30 to 40 degrees from vertical as measured circumferentially around the pipe from its center. Tap in connections that are core drilled shall use a restrained sewer saddle as specified herein.

Tap-In saddles for existing sanitary sewers shall be one of the following:

- ROMAC, Style “CB” Sewer Saddle
- Geneco, Sealtite Type “U” Multi-Range Tee Sewer Saddle

Saddle connections are allowed only if a manufactured fitting does not exist and the mainline pipe is 15-inch diameter or larger.

Saddle connections to vitrified clay pipe (VCP) are not permitted.

The building sewer shall not protrude into the mainline.

Where connections to manhole structures are necessary, rubber water stop joints or rubber gaskets (boots) shall be specified for water tightness between the pipe and the manhole. When new holes into manholes are required, core drilling of the new hole shall be specified. This will require a special approval from the EWSU.

4.4.3.12 Private Pressure Sewer Connection to Main Line Sewer

Connections of pressure sewer laterals to main sewer shall be made according to the plan details.

4.4.3.13 Future Connections to New Mains

Whenever the sanitary sewer main is located in street right-of-way, a six-inch lateral shall be extended to the property line of each lot. The location of each wye and the length of six-inch pipe used shall be shown

on the as-built drawings. The wye shall be factory-constructed wye with a 45-degree bend pointed in the direction of flow in the main sewer. No tee shall be angled at any less than a 50-degree angle with the vertical to eliminate vertical loading of the pipe and wye connection during backfilling. The #7 stone shall be placed under and around the six- inch pipe section of each wye.

Whenever the sanitary sewer is located in an easement, the same requirements must be met. A section of six feet in length shall be stubbed in the easement.

All six-inch laterals shall be sealed with a six-inch cap sealed with glue for plastic pipe. All laterals shall be marked from the lateral end cap to a point five (5) feet above grade with (1") one inch schedule 80 PVC with a (.5") rebar placed inside to protect them from other construction, etc., within the area.

4.4.3.14 Proper Abandonment of Sewer Lateral

Every abandoned building sewer, or part thereof, shall be plugged or capped in an approved manner, within five (5) feet of the property line.

4.4.4 Sanitary Sewer Lift Stations

4.4.4.1 Introduction

In addition to those recommended standards specified by the "Recommended Standards for Sewage Works" (Ten State Standards), the following minimum standards for wastewater lift station design and installation have been adopted by the EWSU.

All sanitary sewer lift stations designed with a daily average flow of more than two-hundred fifty thousand (250,000) gallons per day, are required to have a separate wet/dry well. Lift stations of lesser volumes shall be of the submersible type.

Any variation from these standards requires an approved variance as shown in Chapter 1 – Section 3.

The following basic design elements included in this chapter include:

- Lift Station Location Criteria
- Lift Station Type
- Lift Station Hydraulic Design
- Pumps, Motors and Seals
- Wet Well Design
- Operating Set Points
- Valve Vault, Air Release/Vacuum Valve, and Meter Vault Structures
- Valves, Discharge Piping, Force Main, Meter, and By-Pass Connection
- Sealing Flange
- Ventilation of Structures
- Electrical

- Emergency Operation
- Force Main Design Criteria

4.4.4.2 Lift Station Location Criteria

4.4.4.2.1 Roadway, Parking, and Access Requirements

- A bituminous or concrete paved road (minimum 12'0" width) shall be built to the station, which will accommodate maintenance truck traffic.
- If the station is located on a dead-end street, a paved turn area shall be provided.
- Adequate space for the off-street parking of two vehicles shall be provided.
- The road and parking area must be constructed of bituminous or concrete materials and shall meet current Vanderburgh County street specifications.

4.4.4.2.2 Protection against Flooding

- Wastewater lift stations should remain fully operational and accessible during a 25-year flood event.
- All aboveground structures, hatch openings, valve vaults, wet wells and driveways shall be designed so that they are inherently protected from a 100-year flood event.

4.4.4.2.3 Site Requirements

- A four (4)-foot by four (4)-foot concrete slab, sloping away from the building, shall be provided at the entrance to the building.
- The contractor shall be responsible for developing a lawn around the lift station by sodding or by seeding with Kentucky 31 Variety clear tag grass seed.
- All banks shall have minimum of 3 to 1 slope.
- Optional site requirements depending upon the type and location:
 - Fencing
 - Gates
 - Metering Pit/Metering Piping
 - On-Site Generator and Concrete Pad
 - Chemical Tank

4.4.4.2.4 Mechanical Building

- All lift stations designed with an average daily flow in excess of fifty thousand (50,000) gallons per day shall erect a brick building on the lift station site for mechanical storage, and to house the electrical equipment. The building must have a minimum ceiling height of 8'0", and be 8'0" by 8'0" outside dimensions. The

building must be securely anchored to a minimum 6-inch thick poured-in-place concrete reinforced slab and/or the valve vault slab. The building must be free standing from water.

- The building shall be designed so that it will not detract from the appearance of the surrounding vicinity.
- A 42" wide (minimum) x 7' hollow metal door in a steel frame with 2 finish coats of paint must be installed with a 2' x 2' louver for ventilation, and an aluminum threshold. The door must have a hasp for padlocking provisions.

4.4.4.3 Lift station Type

- Lift stations shall be (at minimum) duplex with submersible type pumps in a wet well.
- Lift stations shall operate automatically under normal conditions but shall be capable of manual control.
- The pump type, number, and configuration shall be consistent with flows and accessibility.
- Pumps and their respective control systems shall be compatible.
- In instances in which only two pumps are provided, the pumps shall be of equal capacity.
- Units shall have capacity such that, with any unit out of service, the remaining unit(s) will have capacity to handle the design peak hourly flow.
- Pumps shall automatically alternate between pumping cycles.
- Both pumps shall be allowed to operate simultaneously at high level set point.
- Valves shall not be located in the wet well. A separate valve vault is required.
- Lifting equipment for pump removal shall be provided. Portable hoist frames and base provisions shall be provided. Ratchet type hoists shall be provided for pumps weighing less than 500 lbs. Other provisions may be required for pumps exceeding this weight.

4.4.4.4 Lift Station Hydraulic Design

4.4.4.4.1 Total Dynamic Head Calculations

The Total Dynamic Head (TDH) shall be calculated for the pumping capacity of the lift station.

The TDH is the sum of the static head, friction losses and minor losses for a given pumping rate in a defined pumping system. TDH shall be calculated as follows:

$$h_{total} = \frac{P_2 - P_1}{\rho g}$$

Where:

- h_{total} is total dynamic head

- P_2 is the pressure at the outlet of the pump
- P_1 is the pressure at the inlet of the pump
- ρ is density of the fluid
- g is standard gravity (9.81 m/s² or 32.17 ft./s²)

Piping friction losses shall be calculated using the following Hazen Williams formula for friction loss:

$$h_f = \frac{7.916L}{k^{1.85}} \frac{Q^{1.85}}{C^{1.85}d^{4.87}}$$

Where:

- h_f is friction loss
- L is the length of the pipe
- R is the hydraulic radius (cross-sectional area per wetted perimeter or A/P)
- C is a roughness coefficient
- d is the inside pipe diameter

4.4.4.4.2 Pump Selection

The pump capacity and system TDH, as calculated previously, shall be used to create the system curve when selecting the pump model. The operating point is defined as the point where the designed system curve ($C = 120$ at Design Flow) intersects the pump manufacturer's performance curve.

The pump, motor, and impeller shall be non-overloading throughout the entire operating range for all roughness coefficients.

The system head curves for each roughness coefficient shall be plotted on the pump performance curve to determine the operating characteristics.

Plot the pump curves in parallel and in the case where both pumps (or multiple pumps) are allowed to operate simultaneously.

The operating point shall fall within the envelope between 70% and 120% of the pump manufacturer's Best Efficiency Point (BEP), based on flow rate.

For example, if the selected pump has a BEP of 300 gpm at 50' TDH, the designed system curve should intersect the manufacturer's pump performance curve somewhere between 210 gpm and 360 gpm regardless of TDH. If the system curve intersects the pump performance curve outside of that range, a different pump should be evaluated.

Engineering judgment may be used when evaluating pump alternatives. If justified, the EWSU Engineering Department may require a different operating point or an alternate pump to be used.

Pumps shall have a five (5) year warranty provided by the manufacturer. The developer shall warrant all equipment, materials, and workmanship in the installation against defects or failures of any kind for a period of one (1) year upon Utility acceptance of the lift station for operation and maintenance.

4.4.4.4.3 Net Positive Suction Head

The Available Net Positive Suction Head ($NPSH_A$) shall be calculated using the following equation:

$$NPSH_A = \frac{p_{atm}}{\gamma} + Z_s - \frac{p_v}{\gamma} - h_{L_{ent}} - h_{L_f} - \sum h_{L_m}$$

Where:

- $NPSH_A$ is the Available Net Positive Suction Head
- $\frac{p_{atm}}{\gamma}$ is the atmospheric pressure head
- Z_s is the static suction head at the impeller eye (negative if there is a suction lift)
- $\frac{p_v}{\gamma}$ is the vapor pressure head
- $h_{L_{ent}}$ is the entrance headloss
- h_{L_f} is the suction pipe friction headloss
- $\sum h_{L_m}$ is the sum of minor losses of valves and fittings

The $NPSH_A$ is compared to the Required Net Positive Suction Head ($NPSH_R$), which is specified by the manufacturer to minimize cavitation. $NPSH_A$ should always be greater than the $NPSH_R$.

4.4.4.5 Pumps, Motors and Seals

All wastewater pumps shall be of the sealed submersible type and shall be oil-cooled type for handling raw, unscreened sewage.

All pumps shall be of the dual vane enclosed impeller type and capable of passing a 3-inch spherical solid.

All pumps shall be furnished with tandem tungsten carbide faced mechanical shaft seals in an oil-filled seal chamber. Seal chamber shall be fitted with a seal failure probe of the resistance probe type.

All pumps shall have heat sensors imbedded in the motor windings.

Pump speed shall not exceed 1750 RPM. Grinder or recessed impeller (vortex) type pumps will not be considered equal, however, approval of such may be granted under exceptional circumstances and will require a variance.

Pump casting shall be fitted with a replaceable bronze wear ring.

The lift station shall be designed and operated as a duplex (two pump) system for all stations rated under two hundred fifty thousand (250,000) gallons per day (daily average flow), with the capacity of a single pump being capable of pumping the peak daily flow.

An identical uninstalled spare pump, with impeller, shall be furnished upon Utility acceptance of the station for operation and maintenance.

4.4.4.6 Guide Rails

A guide rail system shall be provided for the easy removal of the pump and motor assembly for inspection and service. The system shall not require a person to enter the wet well to remove the pump and motor assembly. Two (2) rails of corrosion resistant stainless steel, or other approved material, shall be provided for each pump. The guide rails shall be positioned and supported by the pump mounting base. The guide rails shall be aligned vertically and supported at the top by attachment to the access hatch frame. One (1) intermediate stainless steel guide rail support is required for each 20 feet of guide rail length.

All pumps shall be equipped with sliding brackets or rail guides. A stainless steel lifting chain of adequate length for the wet well depth shall be provided for each pump. Lifting chain shall be designed with a minimum safety factor five (5). The rails and rail guides shall allow the complete weight of the pump unit to be lifted on dead center without binding and stressing the pump housing. The system shall allow the pump to automatically align the pumping unit to the discharge connection by a simple downward movement of the pump.

Guide rails for the inlet trash-screening basket shall be a minimum on (1) –inch stainless steel pipe.

4.4.4.7 Wet Well Design

4.4.4.7.1 Wet Well Materials

Wet well(s) shall be fabricated of pre-cast reinforced concrete base sections, riser sections, riser flat slab tops. Base sections, riser sections, and flat slab tops shall conform to the requirements of ASTM Specifications C478, latest revision. Joints between pre-cast sections shall be sealed with two (2) rings of flexible butyl rubber sealant.

The wet well base shall be placed on at least twelve (12) inches of leveled and compacted #5 stone.

All hardware and fastener items either located inside or directly connected to the wet well shall be of stainless steel construction.

The wet well access hatches shall have aluminum frames and doors with hinged double doors and locking provisions. The door shall be ¼" thick aluminum floor Plate reinforced to 300 PSF live load. Hinges and all hardware shall be of stainless steel.

Concrete wet wells shall be coated outside with an approved bituminous seal coating. Interior Joints shall be sealed with high strength non-shrink grout. All inlet and outlet pipes through the wet well wall shall be through a cast-in- place opening and provided with a resilient seal.

An inlet trash-screening basket may be required for certain applications. The trash basket assembly shall be complete with access frame and guide rail system for removal.

4.4.4.7.2 Wet Well Sizing

The wet well shall be designed large enough to allow at least twelve (12) minutes elapsed time between successive equipment starts during average flow conditions. The maximum average detention time shall be thirty (30) minutes to prevent the wastewater from going septic.

Except as requested by the EWSU, the wet well floor shall have a fillet at the inner base wall of the wet well to prevent the accumulation of solids.

Wet well minimum inside diameter shall be six (6) feet. Minimum operating range (depth) of the wet well shall be six (6) feet from invert of the influent pipe to the basin bottom. The pumps shall remain submerged during the operation cycle.

4.4.4.7.3 Buoyancy

Buoyancy shall be analyzed on the wet well to determine whether additional methods of restraint are necessary. Mechanical equipment, water weight, and other temporary loads shall not be included in the analysis. A minimum safety factor of 2.0 shall be used.

Buoyancy force, opposing force and factor of safety shall be computed as follows:

- Buoyancy Force = (Displaced Volume) X (Unit Weight of Water)
- Opposing Force = Weight of Barrels + Weight of Bottom Slab + Weight of Top Slab + Net Weight of Saturated Soil Over Bottom Slab Extension + Any Additional Constraints (excluding electrical and mechanical components).
- Factor of Safety = (Opposing Force) / (Buoyant Force) > 2.0.
- If the factor of safety is not > 2.0, restraint measures shall be employed. The EWSU may be consulted in these instances.

4.4.4.7.4 Connection to Wet Well

For proposed lift stations, only one (1) incoming connection to the wet well shall be allowed. The connection shall be of sufficient depth to provide service to the lift station build-out service area.

A manhole shall be located within twenty-five (25) feet of the wet well on the influent line. The Influent line shall be constructed of C1. 52 (min.) Ductile Iron pipe. This manhole shall provide provisions for future line extensions with a minimum of interruptions to existing facilities.

4.4.4.7.5 Hydrogen Sulfide Protection

Coat interior surface of the wet well with an approved material to mitigate concrete deterioration caused by hydrogen sulfide gas.

4.4.4.8 Operating Set Points

All pumps shall stop at the wet well level equal to the minimum level recommended by the manufacturer of the proposed pumps. A minimum drawdown range of at least three (3) feet but not greater than four

(4) feet is desirable between the high level alarm and the pump “stop elevation”. The increment in levels between the multi-pump start points shall be a minimum of one (1) foot. All pumps shall shut off a minimum of one (1) foot below the last pump start elevation. The high water alarm level shall be at or below the invert of the influent pipe invert and at least one (1) foot above the last pump start elevation.

Pipes shall not be used for storage during normal lift station operation. The inlet pipe shall be located between the pumps and on the wall opposite the discharge pipe(s). Influent flows shall not be dropped into the wet well from a distance of greater than two (2) feet to prevent entrained air from entering the pump suction.

4.4.4.9 Valve Vault, Air Release/Vacuum Valve, and Meter Vault Structures

4.4.4.9.1 Valve Vault

A valve vault shall be installed on the discharge piping for ease of accessibility and maintenance of the check and plug valves.

All hardware and fastener items either located inside or directly connected to the valve vault shall be of stainless steel construction.

The valve vault shall be constructed in accordance with the specifications for wet well construction. The minimum inside diameter of the valve vault shall be five (5) feet. The valve vault may also be a rectangular pre-cast or cast-in-place concrete structure with minimum inside dimensions of 4' x 4'. The discharge piping shall be at least three (3) feet below the surface of the grade. The valve vault base shall be placed on at least six (6) inches of leveled and compacted #5 stone. The valve vault shall not be placed on unstable fill due to over-excavation for the wet well construction. All inlet and exit piping through the wall of the valve vault shall be through cast-in-place openings provided with a resilient seal.

The valve vault shall be located directly under the mechanical building (see Mechanical Building specifications for applicability) with direct access through a hatch in the floor of the building.

The valve vault shall be coated on the outside with an approved bituminous seal coating. The valve vault shall also be coated on the interior surface with an approved material to mitigate concrete deterioration caused by hydrogen sulfide gas.

A hinged single door (with locking provisions, if appropriate) access hatch assembly shall be installed on the top of the valve vault. The door, frame, and accessories shall be constructed of aluminum with stainless steel hardware and fasteners. The door shall be rated at 300 PSF live load.

4.4.4.9.2 Combination Air Release/Vacuum Valve Structure

A circular concrete structure with an access hatch shall be provided for combination air release/vacuum valves. A combination air release/vacuum valve shall be placed at high points in the force main to prevent air locking. Long, horizontal runs and changes in slope may require combination air release/vacuum valves.

A combination air release/vacuum valve may be required at low points in the force main.

The location of the combination air release/vacuum valves shall be discussed with the EWSU Engineering Department during design.

Each air release valve and air vacuum valve that exhausts above ground must be equipped with an exhaust pipe extended to a downward facing elbow covered with a corrosion-resistant, twenty-four (24) mesh screened opening at an elevation of eighteen (18) inches above ground level.

Automatic air release/vacuum valves shall not be located in areas within the 100-year flood plain or where flooding may occur, unless the automatic air release/vacuum valve is equipped with an exhaust pipe as described in the paragraph above with extension above the 100-year flood elevation.

4.4.4.9.3 Meter Vault and Sample Point Structure

The structure to house the meter and provide for sampling shall be configured for easy access to the metering equipment and easy access for sampling. The structure shall be a circular concrete structure with an access hatch.

Provisions shall be made to drain or remove accumulated water from the meter vault to the wet well using a sloped floor, floor drain, drain pipe with a P-Trap and a check valve or duckbill in the wet well.

4.4.4.10 Valves, Discharge Piping, Meter, and By-Pass Connection

4.4.4.10.1 Discharge Piping

Discharge piping shall be ductile iron pipe (concrete lined) with flanged ductile iron fittings, and long radius elbows.

4.4.4.10.2 Check Valves

A swing-type check valve and plug valve shall be installed in discharge line of each pump and located in the Valve Vault. Plug valves shall conform to AWWA C504-80 and rated for 150 psi, and shall conform to AWWA C1111, be rated at 150 psi, and shall have a spring-loaded external lever arm.

4.4.4.10.3 Plug Valves

Plug valves shall eccentric design with resilient plug facings.

4.4.4.10.4 By-Pass Connection

For emergency by-pass of the lift station using a portable pump, a tee off of the force main with a connection for by-passing shall be provided.

Provisions shall be made to drain or remove accumulated water from the by-pass riser pipe using a ¾-inch diameter drain line sloped to drain to the wet well.

The by-pass configuration shall consist of the following:

- A shut off plug valve located between tee by-pass riser pipe
- Riser pipe to two feet above grade with socket connection for portable pump

4.4.4.10.5 Metering Equipment

In cases where metering is required, consult with the EWSU Engineering Department for orientation of meter, type of meter and readout requirements.

4.4.4.10.6 Miscellaneous

Valves and piping shall be a minimum 4-inch in size. Piping shall be designed to minimize station head loss yet maintain the cleaning velocity.

An emergency pump auxiliary connection shall be provided on stations designed with a daily average flow in excess of one hundred thousand (100,000) gallons per day. Exceptions to this requirement will be made on a case-by-case basis.

4.4.4.11 Sealing Flange

Electrical enclosures shall be type NEMA 4X for outside use, and type NEMA 12 for use inside the mechanical building (control enclosures to have a hinged dead front panel).

All electrical components shall be installed in the appropriate (prior referenced) enclosures.

4.4.4.12 Ventilation of Structures

Ventilation shall be provided for wet wells, valve vaults, and air release/vacuum valve structures.

No interconnection of ventilation systems shall exist between wet wells and valve vaults.

A minimum of a three (3)-inch wet well vent shall be installed. A mushroom type vent is preferred.

4.4.4.13 Electrical

Electrical enclosures shall be type NEMA 4X for outside use, and type NEMA 12 for use inside and mechanical building (control enclosure to have a hinged dead front panel).

All electrical components shall be installed in the appropriate (prior referenced) enclosures.

The lift station shall have electric-utility-delivered 440 or 240 Volt, 3-phase, 60Hz, 4-wire Delta power. All stations powered by 440 primary voltage shall have a minimum 7.5 KVA single-phase, 240/440 to 120/240 VAC transformer.

Motor starters shall be NEMA-rated magnetic type, with 120 Volt control coil, and three thermal overload relays for three (3)-phase and single-phase service with a minimum size of NEMA-1.

A radio telemetry monitoring system equivalent to Motorola Inrac 2000 MRU+ shall be provided. The lift station electrical alarm components shall be compatible with the existing telemetry system, whereby the alarms shall be linked to the "lift station monitor" located at the Westside Wastewater Treatment Plant through the telemetry system. On duplex systems, a minimum of five (5) contact status-type alarm points shall be provided for monitoring from the lift station. A yagi-type radio antenna shall be externally mounted with connection to the telemetry system.

The automatic pump operation, automatic pump lead-lag alteration, and all control logic commands shall be carried out by a Logic Programmable Controller (LPC) equivalent to an Omron S3D series. The LPC shall be a dry contact input type having an optically DC power source, with a minimum of eight (8) inputs and four (4) outputs and EEPROM memory.

A hand-off-automatic switch for manual operation, and a normal – bypass switch (both labeled as such) shall be provided for each pump.

An adjustable thermostatically controlled 150-watt screw base heater shall be mounted in the control enclosure to prevent electrical equipment failure due to condensation.

Level control shall be by means of sealed polyurethane mercury (or approved equals) float switches. A separate float switch shall be provided for each of the following controls: pumps OFF, lead pump ON, lag pump ON, HIGH wet well level. An indicating light for pump ON/OFF indication (labeled as Pump “x” Run), for each pump, shall be installed on the control enclosure dead front panel, and lit when the pump is ON.

A minimum of one 110 volt, 15 amp, GFI duplex receptacle shall be mounted in the control enclosure. An internal panel light, with switch, shall be installed in the control enclosure panel.

A NEMA 4X junction box for pump make-up connections shall not be located in the wet well but shall be mounted on a pedestal at the wet well or on pedestal at the wet well or on the outside wall of the mechanical building. One-two (2) –inch diameter schedule 80 PVC conduit per pump must be installed from this junction box to the pumps. The conduit, and all connections, must be sealed at both ends with manufacturer-approved watertight seals, or silicone.

A seal-failure alarm, with an indicating light mounted on the control enclosure’s dead front panel (labeled as such), shall be provided for each pump.

An automatically resetting phase monitor shall be installed in the control enclosure.

A Hubble #7410B, 30-amp (or approved equal) female receptacle shall be installed for use as an emergency electrical pump connection.

Each pump shall have an accumulative type elapsed run time meter mounted on the control enclosure dead front panel. The meters shall be a non-resettable type in one-tenth (1/10th)-hour increments.

An externally mounted NEMA 3 red-flashing globe-type alarm light, with a lexan-type cover and wire shield shall be installed. The light shall be activated upon a HIGH wet well level.

A Test-Off-Auto test switch shall be mounted on the control enclosure dead panel for testing all alarm lights.

All alarms shall automatically reset when the alarm condition has cleared. An adjustable 0-15 minute (minimum) time delay relay shall be activated and timed-out prior to alarming the HIGH wet well level condition.

An adjustable 0-30 seconds (minimum) 4PDT time delay relay shall be provided for interruption of float inputs to the LPC. This is used for “protective” restoration of pump power due to brownouts and blackouts.

A power distribution sub-panel, with the appropriate number of breakers (see figure B), shall be mounted in the control enclosure to provide protection to the various circuits.

Each electrical panel shall be wired as per the wiring schematic (see figure B), and labeled with wire markers.

All switches, indicating lights, and push buttons mounted on the control enclosure dead panel shall have engraved plastic legend nameplates (black with white letters) – secured with screws – indicating its function.

All internally mounted electrical components and terminal points shall be clearly labeled.

All panel enclosures (except NEMA 4X) shall be painted with an epoxy-based enamel coating.

4.4.4.14 Emergency Operation

A lift station shall be provided with the equipment necessary for emergency operation by one of the following:

- Dual power feeds and automatic transfer switch
- Standby generator and automatic transfer switch
- Receptacle for portable generator and manual transfer switch
- On-site standby pump
- Connection for portable standby pumping

4.4.4.15 Force Main Design Criteria

4.4.4.15.1 General

The following criteria shall apply to force mains:

- Velocities in force mains shall be kept between two (2) and eight (8) ft/s. For design, the goal is at least 3 ft. /s.
- Minimum acceptable diameter shall be four (4) inches.
- Force mains shall not drain between pumping cycles.
- Force mains shall be designed to resist hydraulic forces.
- Force mains shall be designed to resist surge.
- Force mains shall be designed to enter the gravity sewer system at a point not more than two (2) feet above the flow line of the receiving manhole.
- Tracing wire shall be specified for all non-metallic force mains.

4.4.4.15.2 Materials

Ductile Iron cement lined class 51 and 52 for use in force mains sized four (4) inch and larger constructed per ANSI Specification A21-51-1976 covering thickness design of ductile iron pipe and AWWA Specification C151-76 covering overall specifications and requirements for ductile iron pipe.

PVC C-900 Class 150 pipe for use in force mains four- (4) inch and larger constructed per AWWA Specification C-900-89. All PVC force mains shall be laid with a 12 gauge shielded copper tracing wire placed on the top of the pipe. The wire must be accessible at the valve vault, discharge manhole, air relief valve manholes, and at access boxes when the distance between the above structures exceeds 1000’.

4.4.4.15.3 Valves and Fittings

Force main fitting shall be 150 psi (minimum) Ductile Iron Mechanical Joint. Fittings and piping shall be restrained per AWWA specifications using restrainer glands and blocking or a combination of both.

Automatically operating air relief valves shall be placed at all high points on the force main. They shall be placed in 48” (min.) diameter manholes for ease in access and maintenance.

4.4.5 Low Pressure Sanitary Sewer Systems

4.4.5.1 Introduction

This chapter establishes the minimum standards and technical design criteria for all low pressure sanitary sewer systems (including grinder lift stations) located in the EWSU service area. The main reason for acceptance of low pressure sewer systems is for septic elimination in areas of failed or failing septic systems and a gravity system just isn’t an option. Low pressure sewer systems will not be approved for new development. All variances from these design standards must be approved prior to commencement of design in compliance with Chapter 1 Section 3 – Variances.

The intent of this section is to work in conjunction with and as a complement to the recommended standards specified by the “Recommended Standards for Sewage Works” (Ten State Standards). In the event that the two sets of standards are at odds, the stricter of the two standards shall hold.

The following basic design elements included in this chapter include:

- Low Pressure Sewer system Service Area
- Responsibility
- System Design and Layout
- Maximum Connections to Grinder Lift stations
- Grinder Pump Type
- Grinder Pump Equipment

4.4.5.2 Low Pressure Sewer System Service Area

If a low pressure system is necessary for a given area, a study of the area will need to be conducted and reviewed by the EWSU. If the parts of the area can be served through gravity sewers and other parts through a low pressure system, it must be evaluated to determine the best option.

4.4.5.3 Responsibility

The EWSU will only be responsible for the operation and maintenance of the common force main, i.e. the main line low pressure force main, and the portion of the sanitary sewer lateral from the common force main to the right-of-way or easement.

The property owner shall be responsible for all piping, pumping equipment, and appurtenances between the building and the right-of-way or easement.

4.4.5.4 System Design and Layout

Due to the varying conditions of each site, the design of low pressure sanitary sewer systems shall rely on sound engineering judgment and manufacturer's recommendations. The EWSU may, if reasonably justified, make any requirement deemed necessary to assure the system performs as intended.

The minimum requirements for the design and layout of low-pressure sewer systems shall be per the most recent version of the Standard Detail Sheets, the manufacturer's recommendations, and as follows:

4.4.5.4.1 Pipe Size

Pipe size for the common force main shall be per pump manufacturer's recommendations. Minimum size of the grinder lift station discharge force main shall be one and one-quarter (1 ¼) inches.

4.4.5.4.2 Overall System Design/Layout

The design shall be as follows:

- Sufficient to achieve a minimum cleansing velocity of two (2) feet per second in the common force main, at least once per day; and
- Without any "loops" or parallel pumping segments in the system.

4.4.5.4.3 Cleanouts

Cleanouts shall be located per pump manufacturer's recommendations but at a minimum at the following locations:

- At the terminal end of each common force main; and
- Where two (2) or more force mains are connected.

4.4.5.4.4 Air Release Valves

Air release valves shall be installed at the following locations:

- All high points in the system; and
- At intervals of 2,000 feet on all horizontal runs lacking a clearly defined high point.

4.4.5.4.5 Sanitary Sewer Lateral Connection

- Engineer, builder and/or property owner to provide to EWSU information on proposed pump system and force main alignment. EWSU will approve all grinder lift stations before commencing construction.
- All sanitary sewer lateral connections shall have two (2) check valves on the discharge force main line from the grinder lift station.
- Engineer, builder and/or property owner shall contact the EWSU at time of grinder lift station and force main connection for waste discharge.
- Installation will be inspected by the EWSU.

4.4.5.5 Maximum Connections to Grinder Lift stations

No more than one (1) building will be permitted to connect to a grinder lift station.

Common grinder lift stations for one (1) building with multiple residential units are also prohibited.

The intent is to have individual residential units be served by individual grinder lift stations.

Industrial facilities will be handled on a case-by-case basis.

4.4.5.6 Grinder Pump Type

To assure all the grinder lift stations are compatible, all units serving the same low pressure sewer system shall be the same make and model number, and have the same pump performance characteristics, unless justified.

Replacement units shall be the same make and model as was originally approved by the EWSU.

The type of grinder pumps and allowable applications are as follows:

- Positive Displacement Pumps
May be used in all low pressure sewer system applications.

4.4.5.7 Grinder Lift station Equipment

Simplex or duplex grinder pumps may be used for single dwelling units. For uses other than single dwelling units, the Engineers shall determine which is appropriate.

4.4.5.7.1 Grinder Lift station

The grinder lift stations shall be a complete package consisting of all equipment and appurtenances required for a fully operable pumping system. Pump, wet well, level controls, starter, alarm, piping, fittings, valves, and all accessories shall be part of a factory fabricated package so that after burying the wet well, the field connection of the gravity lateral, discharge line and electrical service line to the control box will complete the installation.

4.4.5.7.2 Manufacturer

Each grinder lift station shall be manufactured and assembled by a single manufacturer.

4.4.5.7.3 Pumps

The pumps shall be capable of macerating all materials in normal domestic and commercial wastewater, including reasonable amounts of foreign objects such as wood, plastic, glass, rubber, and the like to a fine slurry that will pass freely through the pump and a one and one-quarter (1 ¼) inch discharge pipe.

4.4.5.7.4 Electrical Motor and Level Controls

Electrical and level controls shall be provided by the pump manufacturer. All controls shall be mounted so they can be cleaned or replaced without disturbing the pump or piping.

4.4.5.7.5 Control Panels

The control panels and all associated components on each standard unit shall be U.L. Approved and installed per manufacturer's recommendations. All equipment associated with each unit shall meet the current requirements of all applicable Federal, State, and Local electrical codes.

4.4.5.7.6 Generator Hook Up

The grinder lift station shall be equipped with a generator receptacle for hook up.

The Engineer and manufacturer are responsible for assuring the equipment is designed properly and will operate in a safe manner.

4.5 Water Main Design

4.5.1 Purpose

The purpose of this chapter is to provide requirements on the design elements and basic hydraulic criteria necessary for the proper design of potable water distribution systems. This chapter establishes the minimum standards and technical design criteria for all EWSU water distribution systems. All EWSU projects and all projects connecting to the existing distribution system shall follow these requirements. All variances from these design standards shall be approved prior to commencement of design in compliance with Chapter 1, Section 3 Variances.

4.5.1.1 Basic Elements of Design

- Horizontal alignment with consideration of separation from sanitary and storm sewers, potential sources of contamination, and efficiently provide service to existing and potential water service users while respecting maintenance and accessibility needs.
- Vertical alignment with consideration of service depth, minimum cover, underground utility conflicts, separation from sanitary and storm sewers, and constructability with respect to maintenance and accessibility requirements.
- Total design flow with consideration of existing and future population served by the water main.
- Water main size, material, bedding and construction method.

- Necessary appurtenances and additional items required for a complete functional, accessible, and maintainable water system.

4.5.1.2 Covered in this Chapter

- General Improvement Location Criteria
- Horizontal Alignment Criteria
- Vertical Alignment Criteria
- Pipe Bedding and Backfill
- Pipe Materials (Reference Evansville Water and Sewer Utility Material Specifications)
- Design Flow
- Hydraulic Design Criteria
- Water Main Pipe Criteria
- Joint Restraint
- Casing Pipe
- Infrastructure Crossings

4.5.2 General Improvement Location Criteria

General improvement location criteria of proposed water main alignment to be considered shall include, but not be limited to the following:

- Use of existing rights-of-way and/or easements whenever possible. Dedicated easements are preferred. Coordinate with responsible road authorities to determine existing utility placement and best location available.
- Easements shall be required for all water main installations along proposed major corridors and non-residential streets. Consult Evansville Water and Sewer Utility regarding easement acquisition for water main installation.
- Easement requirements, property values, and potential damages to all affected properties.
- Evaluate service needs of both present service area and future service area, while avoiding creation of dead end mains.
- Potential development and utility or street extensions and widening into adjacent areas.
- Serve entire area in best way possible.
- Existing underground and overhead utilities, roadways, and railroads.
- Proposed utilities such as sewer, stormwater, and other water facilities. These locations should be avoided for consideration.

- Environmentally sensitive areas including creeks, rivers, wetlands, trees, protected habitats, etc.
- 100-year flood elevations and regulatory floodways. Proper valve placement will be required to isolate any water mains in these areas.
- Continuity with adjacent design segments.
- Maintenance of traffic during construction.
- Availability of materials. Reference the EWSU Water Material Manual for guidance.
- Construction costs.
- Subsurface conditions: soils and ground water.
- Access for maintenance and repair.

4.5.3 Horizontal Alignment Criteria

In general, water main shall be located on the opposite side of the street from the sanitary sewer. Every effort shall be made to locate the water main outside of the pavement, but within existing or proposed right-of-way or easements. Easements are preferred to street rights-of-way. Refer to Chapter 1, Section 6-Easements for further guidelines regarding water main easements.

4.5.3.1 Placement in Existing Right-of-Way (in cases where easement is not feasible)

For water mains located within existing or proposed street right-of-way, the preferred placement shall be as generally defined in Standard Drawings DW13 through DW15.

Allowances for future sidewalk shall be made.

The location of the roadway, curb and gutter, sidewalk and other utilities shall be taken into account.

4.5.3.2 Placement Outside of Existing Right-of-Way

Where water mains are not placed within right-of-way, easements shall be procured.

Easements adjacent to the right-of-way shall be required for all water main installations along major corridors and non-residential streets.

Refer to Chapter 1, Section 6-Easements for minimum easement widths required for water main installation.

4.5.3.3 Minimum Horizontal Separations from Sewers (327 IAC 8-3.2-9)

Refer to Standard Drawing WW-12 Proposed Sanitary Sewer and Existing Water Line Crossing. A ten (10) foot horizontal distance edge to edge shall be maintained between water main and any existing or proposed gravity or pressurized sanitary or storm sewer line or structure.

The crossing must maintain a minimum angle of intersection of 45 degrees (45°) measured from the centerlines of the water main and sewer line. This angle of intersection shall be maintained for a minimum distance of ten feet (10') from either side of the water main.

If it is not possible to maintain the ten (10) foot horizontal separation, the following design criteria shall apply:

- Installation of the water main closer to the sewer may be approved, provided that the water main is in a separate trench or on an undisturbed separate earth shelf located on one side of the sewer and at an elevation such that the bottom of the water main is at least 18 inches (18") above the top of the sewer.
- The sewer and water main shall not be in contact
- The sewer shall be constructed of water main grade pipe material with pressure rated joints. The approved material for the sewer is PVC SDR-21 or PVC C-900.
- The sewer must be pressure tested in the same manner as water main, must maintain a pressure of 150 psi for two (2) hours test duration.
- The sewer joints are compression type joints that are placed equidistant from the centerline of the water main

4.5.3.4 Minimum Distance from Buildings

Water mains (not service lines) shall be located a minimum of ten feet (10') horizontally from edge of pipe to edge of any part of a building structure or its foundation.

4.5.3.5 Minimum Distance from Storage Tanks

The following shall apply when storage tanks are in the vicinity of the proposed water main:

- **Storage Tanks Containing Hazardous Materials:** Water mains shall be separated from existing and proposed above ground or underground storage tanks and their local distribution devices (pumps) containing or potentially containing hazardous materials, petroleum products, or waste materials by a distance of twenty five feet (25') horizontally measured from the outside edge of the water main to the outside edge of the tank or distribution device and shall not cross such tanks or local distribution devices.
- **Other Storage Tanks:** Water mains shall be separate from all other below ground storage tanks not defined above (excluding potable water storage tanks) by ten feet (10') measured horizontally from the outside edge of the water main to the outside edge of the storage tank.

4.5.3.6 Minimum Distance from Liquid Petroleum and High Pressure Piping

Liquid Petroleum and any high pressure piping shall be separated from water mains in the same manner as sanitary and storm sewer lines and related structures or the respective owner's specifications. In the event of conflicting specifications, the more stringent shall apply. Ductile iron water main pipe may be required by EWSU, in lieu of PVC pipe, when in the vicinity of petroleum piping.

4.5.3.7 Minimum Distances from Utilities Other than Sewers

When practical, all utility lines not addressed in other sections (electric, cable, telephone) shall be separated a minimum of three feet (3') or per the respective owner's specifications. In the event of conflicting specifications, the more stringent shall apply.

All drawings shall show the location of both existing and proposed underground and overhead utilities.

Utility locations shall be derived from the most reliable and up-to-date information.

Each utility shall receive a set of drawings prior to final submittal. On these drawings, they shall note changes or addition to utility information.

Separation distance of water main from other utilities shall be determined by the representative of other utilities and the applicant.

Any necessary relocation shall be closely coordinated with the respective utility representative.

4.5.3.8 Minimum Distance from Potential Contamination Sources

The following shall apply when potential contamination sources are in the vicinity of the proposed water main:

- **Sewage or Septic Areas:** Water mains shall be separated from sewage or septic treatment equipment and septic tank absorption field trenches and lift stations by ten feet (10') measured horizontally from the outside edge of the water main to the outside edge of the defined structure.
- **Grave Sites:** Water mains shall be separated from grave sites by ten feet (10') measured horizontally from the outside edge of the water main to the outside edge of the grave site.
- **Landfills:** Water mains shall be separated from existing or proposed landfills by fifty feet (50') measured horizontally from the water main to the outside edge of the waste boundary of an existing or proposed landfill. In addition, water mains within three hundred feet (300') of the outside edge of the waste boundary of an existing or proposed landfill shall be constructed of non-permeable materials. Water mains shall not cross or pass through the waste boundary of an existing or proposed landfill.
- **Organic Compounds:** Where distribution systems are installed in areas of groundwater contaminated by organic compounds, pipes and joint materials which are not subject to permeation of the organic compounds shall be used. The non-permeable materials shall be used for all portions of the system including the water main, service connections, and hydrant leads.

4.5.3.9 Location in Relation to Streams and Waterways

Water mains located along existing or proposed streams or waterways shall be located outside of the stream bed or edge of the water line and sufficiently separated to allow for future improvements to the stream or waterway channel.

Refer to the Standard Drawing DW-12 Typical Channel Crossing.

Water mains shall be separated from existing or proposed water bodies by a minimum of ten feet (10') horizontally measured from the outside edge of the water main to the outside edge of the typical water line or ditch outside edge if the stream is intermittent.

If bridge structure wing walls are present at the stream or waterway crossing, a minimum distance of three (3) feet horizontal must be maintained between the outer edge of the wing wall and the outer edge of the water main pipe.

Water mains going under surface water bodies greater than fifteen (15) feet in width at the crossing point shall:

- Be constructed with watertight, flexible joints;
- Have valves placed at both ends of the surface water body that are accessible from the ground surface and not subject to flooding; and
- Have the upstream valve installed in a manhole structure or meter pit, with permanent taps made on each side of the valve in the manhole structure or meter pit to allow insertion of a leakage meter and to allow for sampling purposes

4.5.3.10 Allowable Horizontal Pipe Deflection

When it is necessary to deflect pipe horizontally from a straight line, the amount of joint deflection for PVC pipe shall not exceed one percent (1%). Consult the manufacturer's recommendations for allowable joint deflections greater than one percent (1%) and for allowable pipe deflections.

The allowable joint deflection for ductile iron pipe shall be per manufacturer's recommendation.

4.5.3.11 Angle of Intersection

Water mains are preferred to cross other utility conduits, highways, and railroads at ninety degree (90°) angles.

4.5.4 Vertical Alignment Criteria

4.5.4.1 Minimum Depth of Cover

Minimum depth of cover for all water main pipes shall be forty eight inches (48") as measured from the proposed surface elevation to the top of the water main pipe.

Minimum depth of cover for service lines shall be thirty six inches (36"). Under pavement sections, services shall be a minimum of sixty inches (60") below pavement surface.

4.5.4.2 Minimum Vertical Separation from Sewers

Refer to Standard Drawing WW-12 Proposed Sanitary Sewer and Existing Water Line Crossing.

A minimum vertical separation of eighteen inches (18") measured vertically from the outside edge of the water main to the outside edge of any existing or proposed gravity or pressurized sewer line or structure shall be maintained per 327 IAC 8-3.2-9.

When crossing a sewer, the eighteen inches (18") vertical separation shall be maintained for a minimum distance of ten feet (10') from either side of the water main as measured from the outside edge of the water main to the outside edge of the sewer line.

If it is not possible to maintain the eighteen inch (18") vertical separation, the following criteria shall apply:

- Installation of the water main closer to the sewer may be approved, provided that the water main is in a separate trench or on an undisturbed separate earth shelf located on one side of the sewer and at an elevation such that the bottom of the water main is at least eighteen inches (18") above the top of the sewer.
- The sewer and water main shall not be in contact
- The sewer shall be constructed of water main grade pipe material with pressure rated joints. The approved material for the sewer is PVC SDR-21 or PVC C-900.
- The sewer must be pressure tested in the same manner as water main, must maintain a pressure of 150 psi for a duration of two (2) hours.
- The sewer joints are compression type joints that are placed equidistant from the centerline of the water main

4.5.4.3 Air Release Structures

Air Release Valves or similar shall be installed in locations where the vertical alignment of the water main results in a high point in the elevation.

Refer to Standard Drawing DW-06 Air Relief Assembly for air release structure requirements.

4.5.4.4 Stream and Waterway Crossings

Refer to the Standard Drawing DW-12 Typical Channel Crossing.

Water mains located above streams, waterways or any water bodies are not allowed.

Water mains located under existing or proposed streams, waterways or water bodies less than fifteen feet (15') in width at the crossing point shall be covered with a minimum of thirty-six inches (36") of cover and constructed with watertight, flexible joints.

Water mains crossing under existing or proposed streams, waterways or water bodies greater than fifteen feet (15') in width at the crossing point shall be covered with a minimum of thirty-six inches (36") of cover, constructed with watertight, flexible joints, have valves placed at both ends of the surface water body. The valves shall be easily accessible, not subject to flooding, and have the valve closest to the supply source located in a manhole structure. It is required to have permanent taps made on each side of the valve within the manhole to allow insertion of a small meter to determine leakage and for sampling purposes.

4.5.4.5 Allowable Vertical Pipe Deflection

When it is necessary to deflect pipe vertically from a straight line, without fittings, the amount of joint deflection for PVC pipe shall not exceed one percent (1%). Consult the manufacturer's recommendations for allowable joint deflections greater than one percent (1%) and for allowable pipe deflections.

The allowable joint deflection for ductile iron pipe shall be per manufacturer's recommendation.

4.5.5 Pipe Bedding and Backfill

See Standard Drawing DW-01 Typical Water Main

All backfill for valves and curb stops shall be No. 11 stone per gradation specification contained in INDOT Standard Specifications, latest edition.

Field bed stone shall be used as backfill for hydrants to promote drainage.

4.5.6 Design Demand

In general, water mains shall be designed to provide for the Design Demand in accordance with the criteria established below. The calculated average and peak demands shall be considered during the design process.

4.5.6.1 Method 1 - General Average Daily Demand for Residential Connections

The average daily demand for residential service connections can be determined by using a general average daily demand value. The following method shall be used to calculate average and peak supply quantity requirements:

$$\text{ADCD} = (\text{General Avg}) \times \text{PRSC}$$

$$\text{PDCD} = (\text{ADCD} \times \text{PF}) + \text{FF}$$

Where:

- ADCD = Average daily consumer demand in gallons per residential service connection per day
- PDCD = Peak daily consumer demand in gallons per residential service connection per day
- General Avg = General average daily consumer demand value of five hundred (500) gallons per residential service connection per day
- PRSC = Proposed number of residential service connections
- PF = Peak daily consumer demand factor of two and one-half (2.5)
- FF = Fire flow demand value equal to the fire protection flowrate provided by EWSU

4.5.6.2 Method 2 – From MRO Data for Residential Connections

The average daily demand for residential service connections can be determined from monthly reports of operations. The following method shall be used to calculate average and peak supply quantity requirements:

$$\text{ADCD} = (\text{Max Average}) \times \text{PRSC}$$

$$\text{PDCD} = (\text{ADCD} \times \text{PF}) + \text{FF}$$

Where:

- ADCD = Average daily consumer demand in gallons per residential service connection per day
- PDCD = Peak daily consumer demand in gallons per residential service connection per day

- Max Average = Maximum average daily consumer demand in gallons per service connection as calculated by:

$$\text{Max Average} = (\text{ADCD10}) / (\text{SC10})$$

Where:

- ADCD10 = The highest average daily demand as reported on the MROs over the previous ten (10) year period
- SC10 = The number of service connections at ADCD10
- PRSC = Proposed number of residential service connections
- PF = Peak daily demand factor as calculated by the following:

$$\text{PF} = \text{MDD10} / 10\text{YADD}$$

Where:

- MDD10 = The maximum single day demand as reported on the MROs over the previous ten (10) year period
- 10YADD = The ten (10) year average daily demand as calculated from the previous ten (10) year period.
- FF = Fire flow demand value equal to the fire protection flowrate provided by EWSU.

4.5.6.3 Method 3 – For other than Residential Connections

The average daily demand for non-residential service connections can be determined from factors from Table 4-4. The following method shall be used to calculate average and peak supply quantity requirements:

$$\begin{aligned}\text{ADCD} &= \text{DCF} \times \text{PSC} \\ \text{PDCD} &= (\text{ADCD} \times \text{PF}) + \text{FF}\end{aligned}$$

Where:

- ADCD = Average daily consumer demand in gallons per service connection per day
- PDCD = Peak daily consumer demand in gallons per service connection per day
- DCF = Demand calculation factors as contained in Table 4-4
- PSC = Proposed number of service connections
- PF = Peak daily consumer demand factor of two and one-half (2.5)
- FF = Fire flow demand value equal to the fire protection flowrate provided by EWSU

TABLE 4-4 DEMAND FACTORS

SERVICE CONNECTION DESCRIPTION	DCF (GALLONS PER DAY)
Airport	3 per passenger plus 20 per employee
Assembly Hall	3 per seat
Bar (without food service)	10 per seat
Beauty Salon	35 per customer
Bowling Alley (with Bar and/or Food)	125 per lane
Bowling Alley (without Food Service)	75 per lane
Bus Station	3 per passenger
Campground Organizational w/Flush Toilets	40 per camper
Campground Organizational w/o Flush Toilets	20 per camper
Campground Recreational with Individual Sewer Connection	100 per campsite
Campground Recreational without Individual Sewer Connection	50 per campsite
Church with Kitchen	5 per sanctuary seat
Church without Kitchen	3 per sanctuary seat
Correctional Facilities	120 per inmate
Day Care Center	20 per person
Dentist	750 per chair plus 75 per employee
Factory with Showers	35 per employee
Factory without Showers	20 per employee
Food Service Operations Cocktail Lounge	35 per seat
Food Service Operations Restaurant, not Open 24 Hours per Day	35 per seat
Food Service Operations Restaurant, Open 24 Hours per Day	50 per seat
Food Service Operations Restaurant, Open 24 Hours per Day Along Interstate	70 per seat
Food Service Operations Tavern	35 per seat
Food Service Operations Curb Service (Drive-In)	50 per car space
Hospital, Medical Facility	200 per bed
Hotel	100 per room
Kennel	20 per animal enclosure
Mental Health Facility	100 per patient
Motel	100 per room
Nursing Home	100 per bed
Office Building	20 per employee
Outpatient Surgical Center	50 per patient

SERVICE CONNECTION DESCRIPTION	DCF (GALLONS PER DAY)
Picnic Area	5 per visitor
School Elementary	15 per pupil
School Secondary	25 per pupil
School with Dormitory	100 per bed
Service Station (Gas Station)	400 per restroom
Shopping Center	0.1 per square foot of floor space, plus 20 per employee
Swimming Pool Bathhouse	10 per swimmer
Theater Drive-In	5 per car space
Theater Inside Building	5 per seat

4.5.6.4 Fire Flow

Fire flow (FF) is the fire protection demand based upon the type of construction, size, number of floors, type of occupancy, and exposure of the structures.

4.5.6.4.1 Residential

In the case of residential areas, water mains shall be designed to provide a minimum fire flow demand of 1,000 gpm at the most remote fire hydrant in the project area.

4.5.6.4.2 Commercial and Industrial

Commercial and industrial demand rates will be dependent on the type of facility constructed. These flows will need to be evaluated on a case-by-case basis taking specific facility activity into account. Information from the I.S.O. "Guide for Determination of Required Fire Flow" can provide guidance. Generally, commercial areas range from 1,500-2,500 gpm and industrial areas range from 2,000-3,500 gpm. In the absence of other information, the high end of the above ranges shall be utilized.

Above typical fire flow rates desired by individual facilities may not be possible without private, on-site fire hydrants, water storage tanks, and fire pumping facilities.

4.5.7 Hydraulic Design Criteria

Sound engineering judgment shall be employed when designing water distribution systems. The following sections outline specific design requirements and considerations.

4.5.7.1 Pressure and Flow Rate

All potable water distribution system projects shall be designed to maintain a minimum residual pressure of 20 psi at ground level at all points in the distribution system under maximum daily demand plus fire flow demand. In addition, all distribution systems shall be designed to maintain a minimum static (no flow) pressure of 35 psi.

4.5.7.2 Velocity

Velocity in a water main shall be determined as follows:

$$V = \frac{0.409Q}{D^2}$$

Where:

- V = velocity, ft/sec
- Q = flow rate (referred to as design demand, see above), gpm
- D = nominal diameter of pipe, inches

The maximum velocity of water within a proposed water main under maximum daily demand plus fire flow demand (Design Demand) shall be as follows:

TABLE 4-5 MAXIMUM VELOCITY

PIPE DIAMETER (INCHES)	MAXIMUM VELOCITY (FT/SEC)	CORRESPONDING DESIGN DEMAND (GPM)
6	12.22	1075
8	7.36	1150
12	4.68	1650
16	4.23	2650
>16	Consult EWSU	

4.5.7.3 Data Requirements

4.5.7.3.1 Topographic

Topographic data including proposed ground contours and surface features will be required for water main design. The general improvement location criteria shall be referenced for determining required topographic information.

4.5.7.3.2 Soils Testing (Survey)

Upon approval by EWSU for the use of ductile iron water main a Soil Survey Report Form shall be completed. The presence of corrosive soils along the proposed path of the water main shall be investigated in accordance with AWWA C105/A21.5. All areas not investigated shall be assumed to be corrosive. A formal soil survey report or statement of assumed corrosive soils shall be submitted to EWSU during project design. All ductile iron pipe water main installed within corrosive soils or assumed to be corrosive soils shall be wrapped with polyethylene wrap.

4.5.7.3.3 Flow Testing

Flow testing results, provided by the Developer, representative to each of the points of connection to the proposed project are required for design basis of the proposed project and determine the adequacy of the system to handle anticipated demands.

4.5.7.4 Hydraulic Calculations

Hydraulic calculations that demonstrate the adequacy of design must be submitted with each proposed project. The calculations must be consistent with the requirements for calculations and shall address the existing conditions and translation of the flow test results as well as the determination of the changes in these conditions along existing water mains. The calculations must demonstrate that the proposed design meets the required design flow criteria at all most remote points in the proposed potable water distribution system.

Hydraulic calculations completed for distribution system design must be reproducible using the Hazen-Williams equation.

Commercial programs may be utilized to compute distribution system hydraulic calculations but if requested by EWSU must be reproduced utilizing Hazen-Williams related equations.

4.5.7.5 General Hydraulic Calculation Requirements

4.5.7.5.1 Roughness Coefficients

Proposed projects must address design life expectancy of water mains. The roughness coefficients to be used for existing pipe and proposed pipe are as follows:

TABLE 4-6 ROUGHNESS COEFFICIENTS

C FACTOR	AGE OF PIPE
140	New and Existing PVC Pipe
120	New Ductile Iron Pipe (24" or larger)
120	All Existing Pipe (Less than 20 years)
110	All Existing Pipe (20 to 40 years)
100	All Existing Pipe (Greater than 40 years)

Theoretical methods using constants other than C factors to demonstrate pipe roughness must provide a demonstration of equivalent assumptions. Site specific C factors shall be used for existing pipe in lieu of the C factors presented in this subsection.

4.5.7.5.2 Minor Losses

Minor losses shall be determined when the length of the proposed project is less than 1,500 times the diameter of the included pipe. This determination to include minor losses must be included with the calculations.

4.5.7.5.3 Friction Losses

Friction losses along a water main due to pipe roughness shall be determined when evaluating the adequacy of design. These friction losses can be determined using Hazen-Williams theories. Hardy-Cross theories can be utilized to determine friction losses in loops of water mains.

4.5.7.5.4 Changes Due to Elevation

Hydraulic calculations shall be completed to evaluate static head. The flow test data is applicable to the elevation of the pressure hydrant and its relationship to and translation to the proposed design is necessary.

4.5.7.6 Translation of Flow Test Results

The flow test results prepared by the Developer present current performance capacity in the proposed project area. Using the static pressure, residual pressure, and measured flow rate data from the flow test and the design demand for the proposed project, the following translation of the residual pressure shall be completed:

$$RP_{DD} = ST_{FT} - [(ST_{FT} - RP_{FT})^{0.54} \times \frac{Q_{DD}}{Q_{FT}}]^{0.54}$$

Where:

- RP_{DD} = residual pressure at pressure hydrant location at design demand
- ST_{FT} = static pressure at pressure hydrant location
- RP_{FT} = residual pressure at pressure hydrant location at flow test measured flow rate
- Q_{DD} = flow rate, design demand
- Q_{FT} = flow rate, flow test measured

For larger development projects or main extensions that have significant impact on the distribution system, EWSU shall be consulted to determine the need to review the proposed project utilizing the City's water model.

The engineer shall identify and estimate the highest and lowest finished floor elevations of the development and calculate the pressures available at these locations as part of the completion of the NOI.

4.5.7.7 Existing Water Main Conditions

The flow test pressure hydrant will likely not be the point of connection for the proposed water main. As such, the effect of the existing water mains between the pressure hydrant and the proposed point of connection must be determined. These effects are calculated by minor losses (if required), friction losses, and changes in elevation. Changes in elevation must address both the elevation of the pressure hydrant and the point(s) of connection.

4.5.7.8 Most Remote Tests

Once the point of connection conditions are established, the adequacy of the proposed water main design must be demonstrated by determining if the performance criteria is fulfilled throughout. This shall be accomplished by the use of “most remote tests”.

Most remote tests include the calculation of all performance criteria at all “plausible” most remote locations in the proposed design. This would include but not be limited to all end points to the proposed distribution system, all areas of higher relative elevation, all points of significant point demand, and all points furthest from a point of connection (regardless if end point). Other plausible most remote points may exist and must be investigated.

Each most remote test will include the effects of minor losses (if required), friction losses, and changes due to elevation. Changes in elevation must be relative to the pressure hydrant of the respective flow test.

All remote points must be investigated or stated why a location was not investigated (i.e. redundant).

4.5.7.9 Water Main Over-sizing

EWSU shall be consulted to determine the need for water main over-sizing to accommodate anticipated future demands.

4.5.8 Water Main Pipe Requirements

Water main pipe requirements are as follows:

- PVC C900/C905 DR 18 pipe shall be used for all new water main with nominal pipe diameters of 6 inch thru 16 inch (6”-16”). Consult EWSU for approval of any other pipe material.
- All pipe materials shall be per Water Material Manual of the Evansville Water and Sewer Utility.
- All water main shall be constructed and tested per water construction standards of the Evansville Water and Sewer Utility.

4.5.9 Joint Restraint

Adequate precautions must be taken to prevent the separation of joints at crosses, tees, elbows, hydrants, valves, reducers and plugged ends. This shall be done by the use of restrained joints. Concrete blocking is not acceptable.

4.5.9.1 Restrained Joint Location Requirements

Joint restraint devices are required at the following locations and as directed by the Engineer or Inspector:

- Bends
- Crosses
- Tees
- Fire hydrants
- Reducers (both sides)

- In-line valves
- Plugs or caps
- Pipe inside casings

4.5.9.2 Restrained Joint Calculations

Joint restraint lengths vary depending on multiple factors such as; the type of fitting, surrounding soil conditions, pipe material, pipe diameter, test pressure, depth of bury, restrained length encroachment etc. The Ductile Iron Pipe Research Association (DIPRA) manual contains detailed information on determining the required joint restraint lengths.

4.5.9.3 Restrained Joint Materials

Refer to Standard Drawings DW-09 and DW-10 for standard restrained joints.

Types of restrained joints shall be per Water Material Manual of the Evansville Water and Sewer Utility.

4.5.10 Casing Pipe

In cases where the water main shall be installed inside a casing the following criteria shall apply.

4.5.10.1 Casing Pipe Requirements

Casing pipe shall be bare wall steel pipe with a minimum yield strength of 35,000 psi. The inside diameter of the casing pipe shall be a minimum of six inches (6”) greater than the outside diameter of the carrier pipe joints or couplings. The casing pipe shall have a minimum wall thickness as required below:

TABLE 4-7 CASING PIPE

CASING OUTSIDE DIAMETER (INCHES)	CASING WALL THICKNESS HIGHWAY CROSSINGS (INCHES)	CASING WALL THICKNESS RAILROAD CROSSINGS (INCHES)
16	0.250	0.281
18	0.250	0.312
20	0.250	0.344
24	0.250	0.406
30	0.375	0.469
36	0.375	0.532

Minimum depth of cover of the casing pipe shall be thirty six inches (60”) or as required by the affected highway, railroad, etc.

EWSU reserves the right to require larger diameter carrier pipes to accommodate additional proposed or future utility lines.

Refer to Standard Drawing DW-17 Typical Jacked and Bore Casing Pipe.

4.5.10.2 Casing End Seals

The casing pipe shall have end seals between the casing pipe and the carrier pipe to prevent the entrance of foreign material.

Refer to Standard Drawing DW-19 Typical Casing End Seals.

4.5.10.3 Casing Spacers

The casing pipe and carrier pipe shall be separated by insulators, spacers or skids. The insulators, spacers or skids shall be installed to support the weight of the pipe and its contents. At a minimum, they shall be placed a maximum of one foot (1') from each side of a joint and at maximum ten foot (10') intervals.

Refer to Standard Drawing DW-18 Typical Casing Spacers.

4.5.11 Infrastructure Crossings

4.5.11.1 Railroad Crossings

When any railroad is crossed, the specifications and precautionary measures required by the respective railroad officials shall be followed. A copy of the railroad crossing application and proof of approval from the respective railroad entity shall be submitted to EWSU. In the absence of specific railroad requirements, the following general criteria shall apply:

4.5.11.1.1 Criteria

The following criteria shall apply to instances in which water main construction affects railroad rights-of-way and facilities. In certain instances, the requirements of the specific railroad company may be more stringent than these standards. In those instances, the more stringent standard shall apply.

- Water main shall cross tracks at an angle as close as possible to ninety degrees (90°).
- Water mains crossing beneath railroad tracks shall be constructed in bored and jacked casings.
- Casing pipe under railroad tracks and across railroad rights-of-way shall extend to a point a minimum distance of twenty-five feet (25') from the centerline of the outside track or the right-of-way line, whichever occurs first and a minimum of five feet (5') beyond the top of ditch bank within the railroad right-of-way.
- Water mains laid longitudinally along railroad rights-of-way shall be located as far as practical from the tracks. If the water main is located within twenty-five feet (25') of the centerline of any track, the water main shall be encased or shall be of a special design as approved by EWSU Engineering.
- Casing under tracks and across railroad rights-of-way shall be a minimum of sixty inches (60") deep as measured from the bottom of the track rail to the top of the casing pipe.

- Isolation valves shall be installed on each side of a crossing contained in a casing pipe. These valves shall be installed at a sufficient distance from the crossing so that the pipe can be removed from the casing and replaced, if necessary.

4.5.11.2 Railroad Crossing Drawings

A railroad crossing drawing shall be prepared and address the following:

- Both a plan and profile view shall be provided.
- The following items shall be included on the drawing: relationship between the proposed water and the railroad, angle of crossing, location of utilities, original survey station of the railroad (when available), right-of-way lines, limits of boring or casing liner, topography, and general layout. The profile shall clearly show the water main in relation to both the tracks and existing ground elevations.

The crossing drawing and project drawings shall be submitted to both EWSU Engineering and the appropriate railroad company for review and approval.

4.5.11.3 Highway Crossings

When any highway is crossed, the specifications and precautionary measures required by the respective highway officials shall be followed. A copy of the highway crossing application or Right-of-Way permit and proof of approval from the respective highway entity shall be submitted. In the absence of specific highway requirements, the following general criteria shall apply.

4.5.11.3.1 Criteria

The following criteria shall apply to instances in which water main construction affects highway rights-of-way and facilities. In certain instances, the requirements of the highway department may be more stringent than these standards. In those instances, the more stringent standard may apply.

- Water mains shall cross the roadway at an angle as close as possible to 90 degrees (90°).
- Water mains shall not be placed under roadway bridges where the possibility of restricting the required waterway area of where a possibility of compromising the structural integrity of bridge foundation exists.
- Pipes crossing beneath highways shall be installed by jack and bore method with a casing pipe, tunneling method or micro-tunneling
- Borings under highways shall have a minimum depth of cover of 54 inches (54") as measured from the surface elevation to the top of the casing. The top of the casing shall have a minimum of 48 inches (48") of cover below the invert of existing or proposed ditches.
- Boring under highways shall extend a minimum of 10 feet (10') (measure perpendicularly) outside the outer edge of existing pavement or to the toe of slope

when the roadway is on fill and the top of slope exceeds the 10 feet (10') outside of pavement requirement.

- Water mains laid longitudinally along highway rights-of-way shall be located a sufficient distance outside of the existing edge of pavement to ensure worker and motorist safety during construction and future maintenance.
- If a casing pipe is used, isolation valves shall be installed on each side of the crossing. These valves shall be installed at a sufficient distance from the crossing so that the pipe can be removed from the casing and replaced, if necessary.

4.5.12 Building Services

4.5.12.1 Introduction

This chapter establishes the technical design and construction criteria for all building water services within the Evansville Water and Sewer Utility water distribution system. Any variances from these requirements shall be approved by EWSU and in compliance with the defined variance procedure.

The definition of “service” is that portion of pipe situated between and including the tap and curb stop, which is installed by a contractor and maintained by the EWSU after the expiration of any applicable maintenance bond.

4.5.12.1.1 Plumbing Codes

Building water services shall conform to the latest adopted version of the Indiana Plumbing Code (IPC) 675 IAC 16 and to these standards, whichever is more restrictive.

4.5.12.1.2 Covered in this Chapter

- Service Lines
- Services 2” and Less
- Services Greater than 2”
- Service Meters
- Connections Using an Existing Building Service
- Future Connections

4.5.12.2 Service Lines General

4.5.12.2.1 Sizing Water Service Lines

The AWWA M22 design manual, Sizing Water Service Lines and Meters, is a reference guide for water service design. The latest version of the AWWA M22 design manual shall be used to determine the maximum flows that can be expected, and provide criteria for designing and sizing the proposed service lines and meters from the main.

The AWWA M22 design manual requirements shall be used for all service conditions. If other water service design methods are used they shall require consultation with and approval from EWSU.

4.5.12.2.2 Service Requirements

The minimum diameter of service pipe shall be three-fourths an inch ($\frac{3}{4}$ ") for copper and one inch (1") for HDPE.

Services with private fire hydrants shall be a minimum of six inches (6") in diameter.

Individual services will be required for each house or facility served by the public water supply system. Services shall be individually metered.

All service connections to water mains sixteen inches (16") and greater in diameter shall require approval from EWSU.

The minimum depth of cover above the pipe shall be forty-eight (48") inches.

Pipe materials shall be in accordance with Water Department Material Specifications of EWSU.

Tracing wire shall be installed on all non-metallic water service lines. Refer to Standard Drawings DW-20 through DW-22 for tracing wire installation for water services.

4.5.12.3 Services 2" and Less

Refer to Standard Detail DW-20 Service Installations for requirements for small service installations. Service installations for services two inches (2") in diameter and less shall meet the following requirements:

4.5.12.3.1 Corporation Stops

Corporation stops shall be required at each service line tap to the distribution system.

4.5.12.3.2 Curb Stops

Curb stops shall be installed for each service. Curb stops shall be placed a minimum of eight feet (8') from the side property line. Curb stops shall be located at the property line. All efforts shall be made to install curb stops in grassy areas and keep the curb stop outside of proposed driveway locations. The curb box and lid shall accompany each curb stop and shall be placed flush with the final grade. If a curb box must be located in an area subjected to traffic, a valve box top half and lid shall be installed to support the traffic load. In such case, the curb stop lid shall be located six (6") inches below the valve box top.

Refer to Standard Drawing DW-20 Meter Service Connection for requirements.

4.5.12.3.3 Metering

Water meters shall be installed on each individual water service line. Refer to Standard Drawing DW-20 for Small Water Meter and Drawing DW-22 through DW-24 for Large Service Water Meter.

4.5.12.4 Services Greater Than 2"

Refer to Standard Drawing W-40 Service Installations for requirements for large service installations. Service installations for services greater than two inches (2") in diameter shall meet the following requirements:

4.5.12.4.1 Connection

Services greater than two inches (2") in diameter shall be connected to the water main with a tee and independent valve or a tapping sleeve and valve. All service pipe shall be properly restrained. If a tee is installed, the valve shall be restrained to the tee.

4.5.12.4.2 Metering

Water meters shall be installed on each individual service line. Refer to drawing DW23 for standard 4" meter service connection and drawing DW24 for standard 6" meter service connection. Refer to drawing DW25 for a standard fire service connection.

4.5.12.5 Service Meters

Water meters shall be located outside of buildings. Any meter proposed to be located inside of a building shall be approved by EWSU through the variance procedures outlined in this manual. All meters shall be supplied by EWSU.

4.5.12.5.1 Meter Requirements

Meter sizing must recognize demand needs of the facility served and the route of delivery.

Refer to exhibits DW20, DW22-DW24, and DW26-DW28 for meter spacing requirements during installation.

Meter pits shall be per the requirements as shown in Standard Drawings DW20, DW22, and DW26-DW28.

Remote capabilities as defined by EWSU shall be required on water meters. Water meters shall be set to include installation of wiring from the meter to a radio endpoint in the meter pit lid.

4.5.12.5.2 Bypass Requirements

A bypass around all new meter installations shall be required under any of the following circumstances, where:

- The service line on the outlet side of the meter is two inches (2") or larger. The bypass for a two (2") meter shall be part of the supplied meter setter. The bypass for larger services shall be constructed with the vault
- The water service must not, for any other reason, be interrupted while the meter is being repaired or replaced.

The bypass around the meter shall be furnished and installed by the utility customer according to the Utility's specifications. Refer to drawings DW22-DW24 and DW 26-DW28 for standard installation.

Where existing piping not containing a by-pass is altered to meet any of the above conditions, the alteration shall also include the installation of a by-pass.

A bypass around irrigation lines shall not be permitted.

4.5.12.6 Connections Using an Existing Building Service

Existing building water services may be used in connection with new buildings only when they are found, upon examination and testing, to meet the current code requirements for building water services. No existing lead or galvanized services shall be re-used and no variance request shall be honored regarding re-use of these services.

4.5.13 Appurtenances

4.5.13.1 Introduction

This chapter focuses on the appurtenances necessary for the proper design of potable water distribution systems. This chapter establishes the minimum standards and technical design criteria for water main appurtenances for all City of Evansville water distribution systems. All variances from these design standards shall be approved prior to commencement of design in compliance with the defined variance procedure.

This chapter covers the following items:

- Valves
- Fire Hydrants
- Fittings
- Air Release Valves
- Blow-off Assemblies
- Temporary Test Risers
- Tracing Wire
- Polyethylene Wrap

4.5.13.2 Valves

Valves are to be provided on water mains for isolation of the water distribution system as necessary for inspection and repair.

4.5.13.2.1 Valve Location

Valves shall be located at two (2) branches of a tee intersection.

Valves shall be located as required to maintain the Maximum Allowable Valve Spacing per Table 4-9 below.

4.5.13.2.2 Valve Requirements

Valves materials shall meet the requirements of the EWSU Water Department Material Specifications.

A valve box, lid, and alignment device shall accompany each valve.

Refer to the Standard Drawing DW03 for requirements for installation.

Valves 16" or greater shall be butterfly valves unless tapping valves.

TABLE 4-8 MAXIMUM ALLOWABLE VALVE SPACING INTERVALS

CATEGORY	MAXIMUM SPACING (LF)
Residential	600'
Commercial	500'
Widely Scattered, Limited Future Development	2,500'

Sources: 327 IAC 8-3.2-14, Recommended Standards for Waterworks (10 States) 8.3

4.5.13.3 Fire Hydrants

Fire Hydrants shall be installed along all water mains that are at least six inches (6") in diameter and that have been designed to carry fire flow. Hydrants shall be designed per the following guidelines:

4.5.13.3.1 Hydrant Requirements

All fire hydrant material shall meet the requirements of the EWSU Water Department Material Specifications.

All fire hydrants shall be equipped with an auxiliary valve.

All joints on the hydrant lead shall be fully restrained between the tee at the main and the hydrant.

All hydrant lead piping and fittings shall be DI pipe, wrapped with polyethylene.

Refer to Standard Drawing DW04 for typical fire hydrant assembly.

4.5.13.3.2 Drainage

Hydrants shall be installed in one (1 CY) cubic yard of two (2") inch diameter smooth riverbed gravel to promote drainage. Refer to Standard Drawing DW04 for installation.

No hydrant drainage pit shall be connected to a sewer.

4.5.13.3.3 Location

Fire hydrants shall be located in a manner to provide complete accessibility, and in such manner that the possibility of damage from vehicles or injury to pedestrians is minimized.

Fire hydrants should be located at major intersections and shall not exceed average spacing intervals of 500 feet (500') in residential areas, 400 feet (400') in commercial areas, and 350 feet (350') in industrial or other higher risk areas.

When hydrants are required at intermediate points between intersections they shall be placed near property lines, in locations that avoid driveways and in locations where they will not be damaged.

When set in the lawn space between the curb and the sidewalk, or between the sidewalk and the right-of-way, no portion of the hydrant or nozzle caps shall be within six inches (6") of the sidewalk.

When placed behind curb, the hydrant barrel shall be set so that no portion of the pumper or hose nozzle caps will be less than 12 inches (12") from the back of the curb.

Fire hydrants shall be separated from potential sources of contamination by at least ten feet (10') horizontally measured from the outside edge of the hydrant to the outside edge of the potential contamination source.

4.5.13.3.4 Protection

When structural protection of the hydrant is directed from the developer, engineer, or EWSU, protective guard bollards should be placed. Protective bollards shall be maintained by the property owner.

4.5.13.4 End Points of Water Mains

Automatic flushing devices shall be placed at permanent or temporary end points of water mains.

Refer to Standard Drawings DW33 through DW36 for standard installations of automatic flushing devices.

Flushing devices shall be designed to provide a minimum of 2.5 cubic feet per second of velocity at the point immediately preceding the exit point.

Flushing devices shall not be connected to any sanitary sewer.

4.5.13.5 Fittings

All water main fitting material shall meet the requirements of the EWSU Water Department Material Specifications.

4.5.13.5.1 Water Main Crossing Connection

Water main replacement or proposed water main installation with a proposed connection into the crossing water main shall be completed with a tee fitting and valve, restrained to the new main, and shall not connect with a cross fitting.

4.5.13.5.2 Water Main Deflection

When space allows the preferred method for vertical and horizontal deflections shall be to use a combination of forty-five (45) degree, twenty-two and one half (22 ½) degree and eleven and one quarter (11 ¼) degree bends in lieu of a ninety (90) degree bend.

4.5.13.6 Air Relief Valves

Air relief valves or other air relief devices shall be installed at any intermediate apex points in the water main where air may accumulate in the water main.

Automatic air relief valves shall not be used in areas of 100 year flood plain, or in a pit or manhole where flooding may occur. Manually operated air relief valves shall be used in areas prone to flooding.

Refer to Standard Drawing DW06 for typical air relief assembly.

4.5.13.7 Blow-Off Assemblies

Blow-off assemblies for construction flush and fill shall be placed at all end points of water mains.

Refer to Standard Drawings DW31 and DW32 for blow-off assembly installation detail.

4.5.13.8 Temporary Test Risers

Temporary test risers will be required during construction of the distribution system extension for use in pressure testing and disinfection. If design questions arise, the EWSU Engineering Department shall be consulted to determine the riser locations. In general, the temporary risers shall be installed as required for pressure and disinfection and shall be removed at the end of construction. Corporation cocks will be removed and plugged after chlorination is complete.

Refer to the Standard Drawings DW31 and DW32 for configuration details and requirements for temporary flushing assemblies.

4.5.13.9 Tracing Wire

Tracing wire shall be used for identifying buried water infrastructure. Tracing wire shall be installed on all water main lines, services and hydrants. The tracing wire shall be brought to ground level at each valve and hydrant with a minimum of three (3') feet of additional wire that can be utilized for locating purposes.

Tracing wire material shall meet the requirements as specified in the EWSU Water Department Material Specifications.

4.5.13.10 Polyethylene Wrap (Polywrap)

Poly wrap shall be placed on all ductile iron pipe. All polyethylene wrap material shall meet the specifications detailed in the EWSU Water Department Material Specifications.

4.5.14 Backflow Prevention

4.5.14.1 Introduction

The purpose of this chapter is to provide general backflow prevention requirements for service lines connecting to the Evansville Water and Sewer Utility water distribution system.

The definition of "backflow" from Chapter 1 of these Standards is Flow of water or contaminants into the public water supply distribution system from a source other than the public water supply.

4.5.14.1.1 References

Backflow prevention shall meet the requirements of these standards and the latest adopted versions of the following references, whichever is more restrictive:

- Indiana Administrative Code, 327 IAC 8-10
- Indiana Building Code
- City of Evansville Code of Ordinances 13.15.040-090
- IDEM Cross Connection Control & Backflow Prevention Manual

4.5.14.1.2 Covered in this Chapter

- Submittals and Approvals
- Backflow Prevention Requirements
- Backflow Prevention Exemption
- Types of Backflow Prevention
- Appropriate Use of Backflow Prevention Devices
- Installation Requirements
- Inspection Requirements
- Inspection Reports
- Disconnection/Removal/Bypass

4.5.14.2 Submittals

Any local submittals required for backflow prevention shall be per the requirements of the City of Evansville Code of Ordinances and the policies of the EWSU and shall be through the EWSU engineering department.

4.5.14.3 Backflow Prevention Requirements

Backflow prevention is required for the protection of the City's water distribution system from contamination through uncontrolled cross connections. Applicants that are required to provide backflow prevention shall be responsible for adherence to the City of Evansville Code of Ordinances and the requirements of the IDEM Cross Connection Control and Backflow Prevention Manual.

The definition of "cross connection" as defined in these standards is any physical arrangement, including cross connection control devices not in working order, whereby a public water supply distribution system is directly connected, either continuously or intermittently, with any secondary source of supply, sewer, drain, conduit, pool, piping, storage reservoir, plumbing fixture, or other device which contains, or may contain, and is capable of imparting to the public water supply, contaminants, contaminated water, sewage, or other waste or liquid of unknown or unsafe quality.

Backflow prevention is required when one or more of the following situations apply:

- By Order of IDEM

Backflow prevention is required for proposed or existing facilities if the commissioner of IDEM so orders. This order shall be a written notification from the commissioner of IDEM in accordance with 327 IAC 8-10-4(d). The notice shall specify the nature of the customer activity that necessitates designation of the facility as a cross connection hazard and the date by which the facility must comply with the order.

- By Order of EWSU

Backflow prevention is required for proposed or existing facilities if EWSU so orders. A notice shall be given specifying the nature of the customer activity that necessitates designation of the facility as a cross connection hazard and the date by which the facility must comply with the order.

- New Construction

Backflow prevention shall be required for the following proposed facilities:

- Cross Connection Hazard Facilities - Backflow prevention shall be required for all proposed facilities designated as a cross connection hazard by 327 IAC 8-10-4(c).
- Spec Buildings - Backflow prevention shall be required for all proposed facilities with currently unknown tenants. These facilities are commonly called “spec buildings”.
- Facilities with Carbonated Fountain Soft Drink Machines - Backflow prevention shall be required for all proposed facilities that plan to use carbonated soft drink machines.
- Facilities with Secondary Source of Supply - Backflow prevention shall be required for all proposed facilities that include a secondary source of supply for any use including, but not limited to, emergency use, fire prevention, irrigation or economics.
- Facilities with Fire Protection Service - Backflow prevention shall be required for all proposed facilities that plan to use fire protection service lines into the facility. This does not include those proposed facilities that plan only the use of private, on-site or outside fire hydrants.

4.5.14.3.1 Existing Facilities

Backflow prevention shall be required for the following existing facilities that are proposing modifications:

- Installation of Customer Service Line - Backflow prevention shall be required for all existing facilities if that facility proposes installation of a service line (new customer)

and the existing (or proposed modified) facility meets the criteria for requiring backflow prevention.

- Modifications to Customer Service Line - Backflow prevention shall be required for all existing facilities if that facility proposes modifications to their customer service line and the existing (or modified) facility meets the criteria for requiring backflow prevention.
- Modification to Customer Service Meter - Backflow prevention shall be required for all existing facilities if that facility proposes installing additional or a larger capacity meter(s) and the existing (or modified) facility meets the criteria for requiring backflow prevention.
- Any additional service to a facility must be separated or a backflow device is required.

4.5.14.3.2 Existing Facilities with a Cross Connection

Backflow prevention shall be required for all existing facilities where a cross connection may occur or is possible.

4.5.14.4 Backflow Prevention Exemption

Backflow prevention that has been required by any of section of this chapter may only be granted an exemption of backflow prevention requirements or a lessening of backflow prevention requirements with approval from IDEM. IDEM approval shall be per 327 IAC 8-10-4(e).

4.5.14.5 Types of Backflow Prevention

Backflow prevention devices that are approved for use shall meet the requirements of the IDEM Cross Connection Control and Backflow Prevention Manual. Isolation valves are not acceptable for backflow prevention and are not approved devices for use in backflow prevention. The following are types of approved devices for use in backflow prevention:

4.5.14.5.1 Air Gap (AG)

Air gaps (AG) are acceptable devices for backflow prevention. An AG is the unobstructed vertical distance through a free atmosphere between the lowest opening from any pipe or faucet supplying water to a tank, plumbing fixture, or other device and the flood level rim of the receptacle.

The discharge pipe of an AG shall terminate per one of the following:

- A minimum of two (2) pipe diameters of the discharge pipe or six inches (6"), whichever is the lesser, above the maximum recorded flood level or above the flood level rim of the receiving vessel, whichever is higher.
- A minimum of three (3) pipe diameters of the discharge pipe or six inches (6"), whichever is the lesser, above the maximum recorded flood level or above the flood level rim of the receiving vessel, whichever is higher where:

- a side wall, rib, or similar obstruction is spaced closer than three (3) pipe diameters from the piping affecting the AG or
 - two (2) intersecting walls are located closer than four (4) pipe diameters from the piping affecting the AG
- The minimum AG separation shall be one inch (1”).

4.5.14.5.2 Atmospheric Vacuum Breaker (AVB)

Atmospheric Vacuum Breakers (AVB) are acceptable devices for backflow prevention for only specified types of cross connection hazards as discussed in section Appropriate Use of Backflow Prevention Devices of this chapter. All AVBs shall meet the following requirements:

- Contain an air inlet valve, a check seat, and an airport.
- Installed as near as possible to the cross connection hazard.
- Positioned not less than six inches (6”) from the base of the AVB down to the flood level rim of the receptacle.
- Installed at a location that allows access to the device for maintenance or replacement from floor or ground level without the use of a ladder or similar temporary apparatus.
- Located in an area not subject to flooding, excessive heat, or freezing.

4.5.14.5.3 Pressure Vacuum Breaker (PVB)

Pressure Vacuum Breakers (PVB) are acceptable devices for backflow prevention for only specified types of cross connection hazards as discussed in section Appropriate Use of Backflow Prevention Devices of this chapter. All PVBs shall meet the following requirements:

- Contain an internally loaded check valve and an internally loaded air inlet valve.
- Installed with shut-off valves and test cocks located at each end of the assembly.
- Installed as near as possible to the cross connection hazard.
- Positioned not less than six inches (6”) from the base of the PVB down to the flood level rim of the receptacle and not less than twelve inches (12”) from the centerline of the PVB outlet to the highest outlet, whichever is greater.
- Installed at a location that allows access to the device for maintenance and testing from floor or ground level without the use of a ladder or similar temporary apparatus.
- Located in an area not subject to flooding, excessive heat, or freezing.
- Installed between two (2) tightly closing shut-off valves with its center or datum point a minimum of twelve inches (12”) above the following:
 - Floor level

- The highest downstream piping or shut-off valve
- The highest downstream overflow rim or discharge point

4.5.14.5.4 Double Check Valves (DC)

Double Check Valves (DC) are acceptable devices for backflow prevention for only specified types of cross connection hazards as discussed in section Appropriate Use of Backflow Prevention Devices of this chapter.

All DCs shall meet the following requirements:

- Consist of two (2) tightly closing shut-off valves surrounding two (2) independent acting check valves.
- Contain four (4) test cocks; one (1) upstream of the four (4) valves and one (1) in between each of the four (4) check and shut-off valves.
- Installed at a location that allows access to the device for maintenance and testing from floor level or ground level without the use of a ladder or similar temporary apparatus.
- Located in an area not subject to flooding, excessive heat, or freezing.

Double Check Valves may be installed within a pit upon prior approval from the City.

4.5.14.5.5 Reduced Pressure Principle Backflow Preventer (RP)

Reduced Pressure Principle Backflow Preventers (RP) are acceptable devices for backflow prevention. All RPs shall meet the following requirements:

- Consist of two (2) tightly closing shut-off valves surrounding two (2) independently acting pressure reducing check valves.
- Consist of two (2) independently acting pressure reducing check valves shall surround an automatic pressure differential relief valve and four (4) test cocks; one (1) upstream of the five (5) valves and one (1) between each of the four (4) check and shut-off valves.
- Located to effectively divide the structure into three (3) chambers.
- Reduced pressure in each downstream chamber allowing the pressure differential relief valve to vent the center chamber to atmosphere should either or both check valves malfunction.
- Installed with no additional piping affixed to the pressure differential relief valve port, and with the pressure differential relief valve port a minimum of 12 inches (12") and maximum of 60 inches (60") above floor level.
- Installed at a location where any leakage from the pressure differential relief valve port may be observed or noted.

- Installed at a location that allows access to the device for maintenance and testing from floor level or ground level without the use of a ladder or similar temporary apparatus.
- Located in an area not subject to flooding, excessive heat, or freezing.

4.5.14.6 Appropriate Use of Backflow Prevention Devices

The effective prevention of cross connecting is highly dependent on the use of the appropriate backflow prevention device for the hazard. Air Gap (AG) backflow prevention devices and Reduced Pressure Principle Backflow Preventers (RP) are appropriate for all cross connection hazards. The IDEM Cross Connection Control and Backflow Prevention Manual provides guidance for the appropriate backflow prevention devices for use with facilities that have a cross connection hazard. Facilities shall construct an AG or install a RP or a DC assembly on the customer service line to each of the following:

- Tanks used only to store water from the public water supply for fire suppression that are constructed to maintain the bacteriological quality of the water.
- Secondary sources of supply that:
 - use well water as the only private source of supply;
 - are constructed to maintain the bacteriological quality of the water,
 - produce, without treatment, water meeting the drinking water quality standards.

Facilities shall construct an AG or install a RP on the facility service line to or into a facility having a secondary source of supply of a type other than those identified that is used for only fire suppression. No secondary source of supply of a type other than those identified above shall be physically connected on the facility service line to or into the facility.

Facilities shall construct an AG, or install a RP or PVB on the water line connecting the public water supply to any subsurface land irrigation system.

Any other situation not already discussed or presented in Exhibits W8-1 or W8-2 but requiring backflow prevention shall require an AG or RP.

4.5.14.7 Installation Requirements

Backflow prevention devices shall be installed per the requirements discussed below.

4.5.14.7.1 Location

- Backflow prevention devices shall be installed on the customer side of the service meter.
- Backflow prevention devices shall be installed after the meter (on 5/8" through 2" services) or after the meter bypass line (on 4" or larger services).
- Pit, chamber, manhole or other below grade installation of backflow prevention devices is prohibited with the exception of DC.

- Backflow prevention devices shall be installed at a height between 12” and 60” above the finished floor elevation with the exception of DC in a pit, chamber, manhole or other below grade installation.

4.5.14.7.2 Multiple Services

When two (2) or more piping systems are used for water in a building or industrial plant, extreme care should be taken not to interconnect the systems. There may be a potable water system and systems carrying lesser quality water such as fire protection. To help prevent the possibility of the two systems being interconnected, pipes should be identified adequately by legends and color coding.

4.5.14.8 Inspection Requirements

All backflow prevention devices shall be inspected at the time of installation and results shall be presented to EWSU. To ensure that the backflow prevention devices are maintained in working order, the backflow prevention devices shall be inspected as follows:

- AG – Intervals not exceeding one (1) year
- RP – Intervals not exceeding one (1) year
- DC – Intervals not exceeding one (1) year
- PVB – Intervals not exceeding one (1) year
- AVB – Intervals not exceeding on (1) year
- All cross connection control device inspectors shall be registered with IDEM.

4.5.14.9 Inspection Reporting

Inspection results reporting shall be the responsibility of the facility owner. This includes insuring that the following cross connection control device inspector responsibility is completed:

All required inspection results shall be submitted by the cross connection control device inspector to the customer possessing the backflow prevention device (tenant), facility owner, EWSU, and, if requested, IDEM within 30 days of the inspection or test.

4.5.14.10 Disconnection/Removal/Bypass

Disconnection/removal/bypass of backflow protection shall not be allowed without approval from IDEM.

4.5.15 Fire Services

4.5.15.1 Introduction

The purpose of this chapter is to provide general requirements and guidelines for fire protection and fire suppression service connections to the City of Evansville water distribution system. Any variances from these requirements shall be approved in compliance with the defined variance procedure.

This Chapter does not detail specific building requirements for fire protection or fire suppression systems. Building fire systems are privately owned arrangement of pipes, fixtures and devices designed for stand-

by service from which water supply is taken from the water distribution system for the extinguishment of fires.

4.5.15.1.1 Codes

Fire systems shall be installed as required and in accordance with the Indiana Building Code (IBC), the Indiana Fire Code (IFC) and the National Fire Protection Association (NFPA). These codes shall be referenced directly for specific requirements. All fire services shall conform to the latest adopted version of these codes and to these standards, whichever is more restrictive.

4.5.15.1.2 Covered in this Chapter

- Submittals and Approvals
- General Requirements
- Service Line Separation
- Meters
- Appurtenances
- Installation and Inspection

4.5.15.2 Submittals and Approvals

All project submittals and approvals from the EWSU for fire protection system service connections shall be per the requirements in Chapter 2 Submittals.

4.5.15.3 General Requirements

Fire protection systems shall be adequately designed to provide fire suppression services during fires. The type of fire suppression system (i.e. water, chemical) is subject to approval by state agencies, EWSU and other local officials.

4.5.15.4 Service Line Separation

The fire service and water service lines shall be separate water service lines with independent valves located outside of the facility served.

When two (2) or more piping systems are used for water in a building or industrial plant, extreme care should be taken not to interconnect the systems. There may be a potable water system and systems carrying lesser quality water such as fire protection. To help prevent the possibility of the separate systems being interconnected, pipes should be adequately identified by legends and color coding.

4.5.15.5 Appurtenances

4.5.15.5.1 General

Appurtenances used in conjunction with fire protection services must meet state and local requirements. Materials utilized on the public water supply side of the fire service line shall be consistent with the requirements of the EWSU Water Department Material Specifications.

4.5.15.5.2 Backflow Prevention Device

A backflow prevention device must be present on all fire protection service lines. Backflow prevention shall be in accordance with the IDEM Cross Connection Control and Backflow Prevention Manual.

4.5.15.5.3 Fire Booster Pump

Wherever a fire suppression system has a booster pump installed only for fire suppression, it shall have a control valve installed on the booster pump discharge to automatically throttle the flow as necessary to maintain a minimum of twenty (20) psi gauge, pump suction pressure.

4.5.15.5.4 On-Site Water Storage

In some cases, on-site storage of water for firefighting purposes may be required. EWSU shall coordinate with the facility requiring fire protection services to evaluate these storage requirements on a case-by-case basis.

4.5.15.6 Installation and Inspection

4.5.15.6.1 Installation

Refer to detail DW25 for fire service connection requirements to the water main.

Fire services greater than two inches (2") in diameter shall be connected to the water main with a tee or tapping sleeve and valve with secondary valve at the property line. All service pipe shall be properly restrained.

The secondary valve located at the property line indicates the point of separation of responsibility of the EWSU from the private plumbing.

4.5.15.6.2 Inspection

The fire service connection shall be inspected upon installation.

The connection of the fire protection system to the service, backflow preventers, valves and any other required appurtenances shall be inspected upon installation and the public portion accepted for maintenance.

SECTION 5: Contractors

5.1 Contractor Approval Policy

5.1.1 Purpose

The purpose of this Section is to provide a policy for verifying qualifications of new contractors for water and sewer installation and for quality performance monitoring of existing approved contractors. This policy includes the following:

- Application form for new contractors to apply for approval to construct water and sewer facilities that will be accepted for maintenance by the EWSU
- Requirements for Sanitary Sewer Construction Contractor
- Requirements for Water Construction Contractor
- Requirements for Service Installation Contractor
- Underperformance policy

5.1.2 Applicability

These procedures shall apply to all contractors that construct any extension of or service to a water main or sanitary sewer that is owned, operated, and maintained by the Evansville Water and Sewer Utility.

5.1.3 Existing Approved Contractors

All contractors that are approved for construction of water or sanitary sewer main extensions, water services, and sanitary sewer services, as of January 1, 2017, shall remain on the approved contractor listing and shall be subject to the performance criteria contained within this policy.

5.1.4 New Contractor Application for Approval

All contractors that desire to be considered for approval for construction of water or sanitary sewer main extensions, water services, and sanitary sewer services are required to complete the construction pre-qualification questionnaire. This document is included in this section.

5.1.4.1 Requirements for Pre-Qualification

- Applicants must furnish detailed information with respect to equipment, past work history, references, personnel, and experience together with any other information required within the questionnaire.
- All contractors must be approved for the type of work that they will perform prior to commencing construction work
- The questionnaire must be complete in detail. The EWSU may require additional information for pre-qualification

- No contractor will be pre-qualified unless its Pre-qualification Questionnaire indicates that it has the experience, organization, and equipment sufficient to satisfactorily execute its construction projects and meet the obligations required.
- A financial statement shall be furnished as part of the pre-qualification process, if requested by the EWSU.
- If any significant change occurs in the information included on the contractors' pre-qualification form, notice shall be provided to the EWSU.
- All corporations must provide a certificate from the Secretary of State showing that it is authorized to transact business in the State of Indiana.
- A copy of the certificate of insurance meeting the requirements of the EWSU coverages is required. This requirement is contained in the City of Evansville Code of Ordinances 13.05.190(B) and shall apply to water and sewer construction.
- A copy of the applicable underground utility license from the City of Evansville and/or County of Vanderburgh is required for sewer and/or water construction. Information regarding the underground utility license is found in City of Evansville Code of Ordinances 5.70.060 and 5.70.070.
- A surety bond in the amount directed by City of Evansville Code of Ordinances 13.05.190(B) on file with the EWSU for sewer construction. A surety bond in the amount directed by the Evansville Water and Sewer Policy Manual for water construction.
- Proof of Workers Compensation Insurance.

5.1.5 Compliance with Approved Drawings and Standards

All water and sewer projects will have drawings and specifications that have been reviewed by the EWSU engineering staff. The final approved drawings will be stamped approved with the approval date and reviewer signature. It is the responsibility of all contractors to construct the project according to the approved plans and specifications. The Contractor shall have, on-site, a copy of the stamped approved drawings for the purpose of making sure that the project plans being used during construction are the approved plans.

5.1.6 Performance Criteria and Evaluation

The approved contractor application and submittals for new contractors is for the purpose of verifying the qualifications of new contractors prior to allowing them to construct water or sewer projects or services that will become facilities that the EWSU will maintain in the future. Just as important is verifying that the current list of approved contractors is performing work in accordance with approved plans and the policies and standards of the EWSU. EWSU staff members will periodically visit construction sites for the purpose of verifying construction activities are in compliance with those stamped approved plans and the standards set forth in this manual.

5.1.6.1 Contractor Underperformance

There may be instances where it is determined that the contractor has substantially deviated from the approved plans and specifications or the policies and procedures of the EWSU, without prior approval to do so. Examples of deviations are

- Varying from stamped approved plans without approval from EWSU
- Not providing sufficient notice of commencement of construction
- Not providing sufficient notice of testing
- Extending limits of construction from those shown on the stamped approved plans without prior approval from the EWSU
- Deliberate construction not in compliance with plans, specifications or policies of the EWSU.

5.1.6.2 Notice of Violation and Appeal

In instances of these deviations from policies, the violating contractor shall be issued a notice of violation with the circumstances detailed. The contractor shall be allowed thirty days after the date of the notice to appeal the violation. Appeals shall be made in writing and shall state the Contractors' case as to why the violation should be removed from the record. The EWSU staff will review the appeal and respond, in writing, the final decision. If an appeal has not been made by the contractor within the 30 day period, the violation shall stand.

5.1.6.3 Penalties for Violations

The following penalties shall be imposed on a contractor that has a standing violation after the appeal process has been completed:

- First violation – The contractor shall be placed on probation for a period of one year. During the probationary period, the contractor may continue to perform construction activities it has been qualified to perform. If the contractor accumulates no further standing violations during the probationary period, after the appeal process is complete, the contractor will be reinstated to full approved contractor status.
- Second violation – If a contractor that is on probation for a first violation, receives a second violation during the probationary period, and the violation stands after appeal, the violating contractor will be removed from approved contractor status. Any contractor that is removed from approved contractor status must reapply as a new contractor. Reapplication will not be accepted for a period of one year from notice of removal of the contractor from approved status.

EVANSVILLE WATER AND SEWER UTILITY
1931 Allens Lane
Evansville, IN 47720

Attn: Engineering Department



CONSTRUCTION PRE-QUALIFICATION QUESTIONNAIRE
(USED IN PRE-QUALIFYING CONTRACTORS FOR UTILITY WORK)

SUBMITTED BY (COMPANY)

ADDRESS

CITY, STATE, ZIP CODE

DATE

CONTACT NAME (FOR QUESTIONS) - TELEPHONE & FAX

TAX ID NUMBER

E-MAIL ADDRESS

Figure 5-1 Contractor Pre-Qualification Questionnaire

PREQUALIFICATION CHECK LIST

Below is a checklist of required documentation

- Signed application and boxes checked indicating type of work requested – (Page 4).
- Company information and work history (Pages 5-11).
- Bonding capacity indicated (Page 5)
- Equipment Sheet is complete (Page 12)
- Affidavit is complete with Notary Seal for whichever type of business is applicable.
- Attach Certificate from the Secretary of State showing company is authorized to transact business in the State of Indiana.
- Attach Certificate of Insurance with EWSU as certificate holder.
- Attach Underground Utility license for City of Evansville and/or Vanderburgh County (required for Sewer Construction and Water Construction categories)

**RULES AND REGULATIONS FOR PREQUALIFICATION OF CONTRACTORS
FOR WATER OR SEWER CONSTRUCTION FOR
THE EVANSVILLE WATER AND SEWER UTILITY**

1. An applicant for pre-qualification must furnish, under oath, detailed information with respect to its equipment, past record, personnel, and experience, together with other information as is called for in this Prequalification Questionnaire.
2. A contractor must be prequalified prior to initiating construction of a project.
4. This form must be completed in detail. The EWSU may require any additional information deemed necessary for pre-qualification.
5. No Contractor will be pre-qualified unless its Pre-qualification Questionnaire indicates that it has the experience, organization, and equipment, sufficient in the judgment of the EWSU, that it can satisfactorily execute its construction projects and meet its obligations therein incurred.
6. The Financial Statement of the controlling individual or corporate owner of the business shall be submitted; if in the opinion of the EWSU it is required.
7. If any significant change occurs in the information included on the contractors' pre-qualification form, notice shall be given to the EWSU immediately.
8. All corporations must furnish a certificate from the Secretary of State showing that it is authorized to transact business in the State of Indiana.
9. A copy of your firm's Certificate of Insurance meeting the EWSU coverages is required.
10. A copy of the applicable underground utility license from the City of Evansville and/or County of Vanderburgh is required for Sewer and/or Water Construction.

NOTE: It is important that the work experience pages in Section V be completed and that it contains projects of the type for which pre-qualification is being requested. Pre-qualification will not be granted for types of work that you subcontract to others.

APPLICATION FOR CERTIFICATE OF QUALIFICATION TO BID

The undersigned hereby applies to the Evansville Water and Sewer Utility for pre-qualification to construct the following types of work: (Check each type of work for which qualification is requested)

- Sewer Construction
Section V. A., Page 7. Underground Utility license required for City or County. Sewer Construction shall consist of sewer projects requiring excavation of approximately 20 feet or less in depth and which do not require significant involvement with urban type features such as utilities, structures, urban landscape, other features of an urban nature, or significant amounts of classified excavation.

- Deep Sewer Construction
Section V. B., Page 8. Underground Utility license required for City or County. Deep Sewer Construction shall consist of sewer projects requiring excavation of greater than approximately 20 feet in depth and/or that requires significant involvement with trench bracing or urban type features, or significant amounts of classified excavation. The District shall be the sole judge as to the type of construction each project falls under.

- Sanitary Sewer Tap Installation
Section V. C., Page 9

- Potable Water Main Construction
Section V. D., Page 10

- Water Service Installation
Section V. E., Page 11

TYPE OF ORGANIZATION (Check Applicable Category)

Corporation Partnership Sole Proprietorship Joint Venture

Firm Name: _____ Firm Address: _____

By _____ Title _____

(Signature)

**THE SIGNATORY OF THIS QUESTIONNAIRE GUARANTEES
THE TRUTH AND ACCURACY OF ALL STATEMENTS AND OF
ALL ANSWERS TO INTERROGATORIES HEREINAFTER MADE**

Please list any previous experience or projects your company has completed for each category you are requesting approval for, and any references you can provide. Attach additional sheets if necessary.

Name of Contractor _____

Principal Address _____

- A corporation
- A general co-partnership
- A limited co-partnership
- An individual
- Joint Venture
- MWBE (Minority or Woman Business Enterprise)
If MWBE, what is the name of the agency/organization that issued the certification document?

_____ Please attach a copy of your certification document to this application.

Incorporated or organized:

Date _____ State _____

Radius of operations: _____

Type of work done: _____

Work usually sublet: _____

Name of Bonding Company _____

Total Bonding Capacity of Firm \$ _____

I. How many years have you operated under the above name:

- (a) As general contractor _____
- (b) As subcontractor _____

II. List other names under which you have operated:

Name of company _____

Type of work done _____

Operated during period _____

Name of company _____

Type of work done _____

Operated during period _____

III. List of all partners or officers: (Note: if partnership limited, explain and please list full 100% ownership)

Name and title _____

Address, City and State _____

Fractional interest in firm or number of shares owned _____

Name and title _____

Address, City and State _____

Fractional interest in firm or number of shares owned _____

Name and title _____

Address, City and State _____

Fractional interest in firm or number of shares owned _____

IV. What is the construction experience of the principal individuals of your organization? (This includes the job superintendent).

An individual's name _____

Present position or office _____

Years of construction experience _____

Magnitude and type of work _____

An individual's name _____

Present position or office _____

Years of construction experience _____

Magnitude and type of work _____

An individual's name _____

Present position or office _____

Years of construction experience _____

Magnitude and type of work _____

V. List all experience for the past five years in the categories for which you want to qualify. List projects that are completed or in progress, attach additional sheets if necessary.

SECTION A. - Sewer Construction (See definition on page 4)
(Includes storm sewer, sanitary sewers, and small pump stations)

1. Contract Amount _____
When Completed or Percent Complete _____
Type of Project _____
Pipe size and length laid _____
Location of Project _____
Name, Address & Phone
Number of Owner _____
2. Contract Amount _____
When Completed or Percent Complete _____
Type of Project _____
Pipe size and length laid _____
Location of Project _____
Name, Address & Phone
Number of Owner _____
3. Contract Amount _____
When Completed or Percent Complete _____
Type of Project _____
Pipe size and length laid _____
Location of Project _____
Name, Address & Phone
Number of Owner _____
4. Contract Amount _____
When Completed or Percent Complete _____
Type of Project _____
Pipe size and length laid _____
Location of Project _____
Name, Address & Phone
Number of Owner _____

List all experience for the past five years in the categories for which you want to qualify. List projects that are completed or in progress, attach additional sheets if necessary.

SECTION B. - Deep Sewer Construction (See definition Page 4)
(Includes sanitary sewer, storm sewer, and small pump stations)

1. Contract Amount _____
When Completed or Percent Complete _____
Type of Project _____
Pipe size, average depth and length laid _____
Location of Project _____
Name, Address & Phone
Number of Owner _____
2. Contract Amount _____
When Completed or Percent Complete _____
Type of Project _____
Pipe size, average depth and length laid _____
Location of Project _____
Name, Address & Phone
Number of Owner _____
3. Contract Amount _____
When Completed or Percent Complete _____
Type of Project _____
Pipe size, average depth and length laid _____
Location of Project _____
Name, Address & Phone
Number of Owner _____
4. Contract Amount _____
When Completed or Percent Complete _____
Type of Project _____
Pipe size, average depth and length laid _____
Location of Project _____
Name, Address & Phone
Number of Owner _____

**List all experience for the past five years in the categories for which you want to qualify.
List projects that are completed or in progress, attach additional sheets if necessary.**

SECTION C. Sanitary Sewer Tap Installation

1. Contract Amount _____ When Completed or Percent Complete _____
Type of Project _____
Number of Taps Made _____
Location of Project _____
Name, Address & Phone _____
Number of Owner _____

2. Contract Amount _____ When Completed or Percent Complete _____
Type of Project _____
Number of Taps Made _____
Location of Project _____
Name, Address & Phone _____
Number of Owner _____

3. Contract Amount _____ When Completed or Percent Complete _____
Type of Project _____
Number of Taps Made _____
Location of Project _____
Name, Address & Phone _____
Number of Owner _____

4. Contract Amount _____ When Completed or Percent Complete _____
Type of Project _____
Number of Taps Made _____
Location of Project _____
Name, Address & Phone _____
Number of Owner _____

**List all experience for the past five years in the categories for which you want to qualify.
List projects that are completed or in progress, attach additional sheets if necessary.**

SECTION D. – Potable Water Main Construction
(Includes water main of all sizes)

1. Contract Amount _____
When Completed or Percent Complete _____
Type of Project _____
Pipe size and length laid _____
Location of Project _____
Name, Address & Phone
Number of Owner _____
2. Contract Amount _____
When Completed or Percent Complete _____
Type of Project _____
Pipe size and length laid _____
Location of Project _____
Name, Address & Phone
Number of Owner _____
3. Contract Amount _____
When Completed or Percent Complete _____
Type of Project _____
Pipe size and length laid _____
Location of Project _____
Name, Address & Phone
Number of Owner _____
4. Contract Amount _____
When Completed or Percent Complete _____
Type of Project _____
Pipe size and length laid _____
Location of Project _____
Name, Address & Phone
Number of Owner _____

**List all experience for the past five years in the categories for which you want to qualify.
List projects that are completed or in progress, attach additional sheets if necessary.**

SECTION E. – Water Service Installation

1. Contract Amount _____
When Completed or Percent Complete _____
Type of Project _____
Pipe size and number _____
Location of Project _____
Name, Address & Phone _____
Number of Owner _____
2. Contract Amount _____
When Completed or Percent Complete _____
Type of Project _____
Pipe size and number _____
Location of Project _____
Name, Address & Phone _____
Number of Owner _____
3. Contract Amount _____
When Completed or Percent Complete _____
Type of Project _____
Pipe size and number _____
Location of Project _____
Name, Address & Phone _____
Number of Owner _____
4. Contract Amount _____
When Completed or Percent Complete _____
Type of Project _____
Pipe size and number _____
Location of Project _____
Name, Address & Phone _____
Number of Owner _____

AFFIDAVIT FOR INDIVIDUAL

State of _____)
County of _____) ss.

_____, being duly sworn, deposes and says that the answers to the foregoing interrogatories are true, and that any depository, vendor or other agency herein named is authorized to supply Evansville Water and Sewer Utility with any information necessary to verify this statement.

(Applicant sign here)

Sworn to before me, this _____ day of _____, 20 ____.

Notary Public

(seal)

AFFIDAVIT FOR CO-PARTNERSHIP

State of _____)
County of _____) ss.

_____, being duly sworn, deposes and says that they are a member of the firm of _____ that they are familiar with the books of said firm showing its financial condition; and that the answers to the foregoing interrogatories are true, and that any depository, vendor or other agency herein named is authorized to supply Evansville Water and Sewer Utility with any information necessary to verify this statement.

—

(Members of firm, sign above)

Sworn to before me, this _____ day of _____, 20____.

Notary Public

(seal)

AFFIDAVIT FOR CORPORATION

State of _____)
County of _____) ss.

_____, being duly sworn, deposes and says that ___he is
_____ of the

the corporation described in and which executed the foregoing statement that he is familiar with
the books of the said corporation, showing its financial condition; and that the answers of the
foregoing interrogatories are true, and that any depository, vendor or other agency herein named
is authorized to supply Evansville Water and Sewer Utility with any information necessary to
verify this statement.

Title

Title

Sworn to before me, this _____ day of _____, 20 _____.

Notary Public

(seal)

5.2 Field Adjustment Notification Hierarchy

Whenever adjustments to the approved plans need to be made in the field due to unforeseen conditions, the Contractor must notify the EWSU or its representative prior to making those field adjustments. Figures 5-2 and 5-3 detail the decision escalation process for sewer and water projects respectively.

5.3 Technical Specifications - Sanitary Sewer

5.3.1 Embedment and Backfill

5.3.1.1 General

All trenches or excavations shall be backfilled to the original surface of the ground or such other grades as shown on the Utility approved drawings. In general, the backfilling shall be carried along as speedily as possible and as soon as the concrete, mortar, and/or other masonry work and pipe joints have sufficient strength to resist the imposed load without damage.

5.3.1.2 Definitions and General Considerations

- A. Pipe bedding shall be considered the area used for support directly under the pipe for the full width of the trench. The haunch is the area from the top of the bedding to the springline (horizontal centerline of the pipe) for the full width of the trench. Initial backfill is the area from the springline to twelve (12") inches above the crown (top) of the pipe. Pipe embedment is the total area that includes the bedding, haunch and initial backfill. The final backfill is all of the area above the top of the initial backfill elevation.
- B. Special foundation material may be required under the pipe bedding for areas of unstable soil material (muck) or in areas where pipe grade will be higher than original ground elevation. In circumstances where unstable soil material is encountered, the area shall be excavated and replaced with suitable crushed stone to form a sound foundation. The pipe bedding can then be placed upon the foundation material.
- C. The Developer's Contractor shall not place pipe embedment materials by methods that will damage or disturb the pipe or other utilities. Care shall be taken that compaction equipment shall not come into contact with the pipe. Prior to performing compaction operation over the pipe, the Developer's Contractor must ensure that sufficient backfill is installed over the pipe to prevent damage or excessive deflection.

5.3.1.3 Products

5.3.1.3.1 Bedding and Backfill of Trench Excavations for Pipes and Conduits

Bedding and Backfill materials for pipe installation and trench backfill shall conform to the types detailed in Part 3 of this specification for the specific pipe type installed.

5.3.1.3.2 Structural Backfill

Backfill materials for backfill of structures other than pipes and conduits shall be according to the Standard Details and Utility approved drawings.

For adjustments/changes to a EWSU Approved Sanitary Sewer Plan during the construction of the private development project, the specific escalation process below shall be followed.

They are generally as follows:

If this happens	Then this should happen	EWSU Assigned Insp Firm	EWSU Constr Supervisor	EWSU Design Reviewer
Lateral location change	Notify Insp Firm	Note in IDR		
Additional lateral	Notify Insp Firm	Note in IDR / Contact Super	Note in IDR	
Manhole location adjustment	Notify Insp Firm	Note in IDR		
Additional manhole *	Notify Insp Firm	Note in IDR / Contact Super	Contact Reviewer	Review with EOR
Pipe segment length adjustment	Notify Insp Firm	Note in IDR / Contact Super	Note in IDR	
Pipe segment slope adjustment *	Notify Insp Firm	Note in IDR / Contact Super	Note in IDR / Contact Reviewer	Review with EOR
Total project pipe length change *	Notify Insp Firm	Note in IDR / Contact Super	Contact Reviewer	Review with EOR

* Requires Approval from Reviewer and EOR prior to proceeding.

EOB – Engineer of Record

Additional scenarios encountered during a project should be able to be categorized into one of the seven scenarios above. The contractor is encouraged to take the most conservative approach to changes as work done without necessary approval is at peril to being removed.

Figure 5-2: Sewer Field Decision Escalation Process

For adjustments/changes to a EWSU Approved Water Plan or Large Meter Service during the construction of the private development project, the specific escalation process shall be followed as detailed below:

	Then this should happen		
If this happens	Contractor	EWSU Constr Supervisor	EWSU Design Reviewer
Service location change	Notify Supervisor	Note in IDR	
Additional service **	Notify Supervisor	Note in IDR / Contact Reviewer	Review with EOR and for fee adjustment
Gate valve / hydrant adjustment	Notify Supervisor	Note in IDR	
Valve / hydrant increase / reduction	Notify Supervisor	Note in IDR / Contact Reviewer	Review with EOR
Blowoff increase **	Notify Supervisor	Note in IDR; Review for fee adjustment	
Pipe length adjustment	Notify Supervisor	Note in IDR	
Pipe depth adjustment*	Notify Supervisor	Note in IDR / Contact Reviewer	Review with EOR
Total project pipe length change *	Notify Supervisor	Note in IDR / Contact Reviewer	Review with EOR
Chlorination scenario change **	Notify Supervisor	Note in IDR; Review for fee adjustment	

EOR – Engineer of Record

* Requires Approval from Reviewer and EOR prior to proceeding

** Changes may require additional fees to be paid prior to proceeding

Additional scenarios encountered during a project should be able to be categorized into one of the seven scenarios above. The contractor is encouraged to take the most conservative approach to changes as work done without necessary approval is at peril to be removed.

Figure 5-3: Water Field Decision Escalation Process

5.3.1.4 Execution

5.3.1.4.1 Rigid Pipe Embedment and Compaction

- A. For the purpose of this specification, rigid pipe shall include those made of vitrified clay pipe and other materials of a rigid nature approved by the EWSU.
- B. All rigid pipe shall be bedded and haunched with #5 or #8 crushed stone, gradation specified in INDOT Standard Specifications, latest revision. The pipe bedding shall be placed on a prepared flat trench bottom. The pipe bedding shall extend a minimum of six (6") inches or one half (1/2) the outside pipe diameter to a maximum of eight (8") below the pipe. This same granular material shall be used to haunch (area from the top of the bedding to the springline of the pipe) on both sides of the pipe for the full trench width.
- C. All materials for bedding and haunching shall be placed in the trench in six (6") layers to facilitate compaction. Each layer shall be leveled and evenly distributed on both sides of the pipe so as not to disturb, displace or damage the pipe and shall be thoroughly compacted. Compaction of the crushed stone shall be accomplished by hand tamping or walking in the material. Material for haunching can be compacted by manual compaction methods or by shovel slicing.
- D. For pipe that is constructed under a roadway or has an initial backfill zone within the influence of traffic (below a 1:1 slope from the edge of pavement), the initial backfill material and construction shall be in accordance with the latest highway jurisdictional regulatory standard for the roadway. For areas outside of five (5') feet from the edge of pavement and outside of the influence of traffic, the initial backfill may be suitable excavated materials from the trench. Compacted materials from the trench shall be free from rocks (two inches in diameter or greater), concrete, roots, stumps, rubbish, frozen materials and other similar materials that would cause excessive settlement. Initial backfill materials shall not include top soil, peat or other materials that can't be compacted. All initial backfill materials shall be placed in the trench and compacted as specified.

5.3.1.4.2 Non-Rigid Pipe Embedment and Compaction

- A. For the purpose of this specification, non-rigid pipe shall include those made of PVC, Ductile Iron, and other materials approved by the EWSU.
- B. All non-rigid pipe shall be bedded, haunched, and initially backfilled with #5 or #8 crushed stone, gradation specified in INDOT Standard Specifications, latest revision. The pipe bedding shall be placed on a prepared flat trench bottom. The pipe bedding shall extend a minimum of six (6") inches or one half (1/2) the outside pipe diameter to a maximum of eight (8") below the pipe. This same granular material shall be used to haunch (area from the top of the bedding to the springline of the pipe) and for initial backfill (area from the haunch to twelve (12") inches above the pipe) on both sides of the pipe for the full trench width.
- C. All materials shall be placed in the trench in no more than six (6") inch layers. Each layer shall be leveled and evenly distributed on both sides of the pipe so as not to disturb,

displace or damage the pipe and shall be thoroughly compacted. Compaction of the crushed stone shall be accomplished by hand tamping or walking in the material. Material for haunching can be compacted by manual compaction methods or by shovel slicing.

5.3.1.4.3 Final Trench Backfilling

- A. Final backfill is considered to be all material above an elevation that is twelve (12") inches above the top of the pipe to the bottom of the surface restoration (top soil, pavements, sidewalks, etc.) for the full width of the trench. All sanitary sewer pipe shall be backfilled the same day that it is installed. Prior to using heavy compaction or construction equipment directly over the pipe, ensure that sufficient backfill material is installed over the pipe to prevent damage or excessive deflection.
- B. Compaction of final backfill in areas subject to traffic influence, which are defined as being area subject to routine vehicle usage such as roadways, alleys, driveways, etc. shall be performed according to the latest revision of the roadway regulatory authority standards (State, County or City). The area of traffic influence is normally considered the area within five (5') feet of the edge of pavement, including shoulders as measured from the outermost edge of the pipe trench closest to the edge of the traffic area. It also includes areas within a 1:1 slope from the edge of the traffic area, based upon depth and distance, taken from the outer edge of the pipe closest to the traffic. Placement and compaction of the final backfill shall be in accordance with the standards of the regulatory agency having jurisdiction over the roadway.
- C. Pipes installed in areas not subject to traffic influence may be backfilled with suitable excavated trench soil materials. Excavated trench soil materials shall be placed in uniform layers, compacted as specified, and mounded to accommodate settlement during the project development. Excavated trench material for usage as final backfill shall be free from rocks (two inches in diameter or greater), concrete, roots, stumps, large amounts of sod or organic matter, rubbish, frozen materials and other similar materials that may cause excessive settlement. To allow for settlement, the surface of the trench shall generally be left in a slightly rounded condition.

5.3.1.4.4 Temporary Surfaces Subject to Traffic

The Contractor shall open streets to traffic immediately after completing the backfill operation. The Contractor shall accomplish this by installing the compacted aggregate base immediately after granular backfill. When temporary asphalt pavement is required this shall also be installed immediately. The Contractor shall be responsible for the maintenance of the temporary surface to promote safety of the travelling public.

5.3.1.4.5 Maintaining Trench Surfaces

- A. All surface settlement of the backfill along trenches located beneath streets, roads, alleys, driveways and parking lots which are subject to traffic shall be kept filled level with or slightly above the original paved surface at all times with compacted aggregate base material until the permanent pavement is satisfactorily restored. When temporary asphalt pavement is used, depressions and "pot holes" shall be promptly filled with the

temporary asphalt material. Attention shall be given by the Contractor to the timely and proper maintenance, leveling and grading of the surface of all backfilled trenches, especially those subject to traffic and especially following rains. The surface of streets, roads and alleys shall be maintained smooth and free of ruts and water trapping depressions by periodic blading, scarifying; and/or filling settled areas, ruts, pockets, or holes with compacted aggregate base material or temporary asphalt where used.

- B. In existing residential areas where stone aggregate has been temporarily used to restore the roadway surface, dust prevention may be required to reduce the effect of dust upon local residents.
- C. In areas outside of the influence of traffic, unless otherwise specified, the backfill shall be neatly rounded over the trench to a sufficient height to allow for settlement to grade after consolidation. Prior to the acceptance of the work, any surface settlement below original ground surface shall be refilled and restored.

5.3.1.4.6 Backfill Around Structures

- A. For purposes of this specification, structures shall include but not be limited to footings, foundations, basements, grade beams, vaults, manholes, ducts, tanks, bridges, inlets, headwalls, anchors, and etc. Items specifically excluded from this definition of "structures" are pipe, conduits and their appurtenances except those listed herein.
- B. The material for backfill around structures within a roadway or in areas under the influence of traffic shall be as specified by the regulatory agency having jurisdiction over the roadway. For structure backfill in areas not under the influence of traffic, suitable material removed from the project site may be used provided it is free from rocks (one inch in diameter or greater), concrete, roots, stumps, large amounts of sod or organic matter, rubbish, frozen materials and other similar materials that may cause excessive settlement.
- C. All excavations shall be backfilled to the original surface of the ground or such other grade as shown on the Utility approved plans. The backfilling shall be performed as soon as possible after concrete, mortar and/or other masonry work and pipe joints have sufficient strength to resist the imposed load without damage. All appurtenances and attachments to structure walls shall be made and any wall coatings shall be in place and cured prior to backfilling at that elevation.
- D. Prior to backfilling, all formwork and construction debris will be removed. Any frozen or wet subsoil will be thawed or dried and compacted or removed prior to receiving backfill. During cold seasons, grades receiving backfill will be protected from frost during the work progress.
- E. Structure backfill material in areas under the influence of traffic shall be placed and compacted in accordance with the regulatory agency having jurisdiction over the roadway. In areas outside of the influence of traffic, structure backfill material shall be placed in uniform layers around the structure and compacted, as specified, with mechanical or manual tamping equipment prior to placing each subsequent layer.

- F. Rainfall and/or groundwater trapped in the excavation during backfill operations shall be pumped out by the Contractor. Excessively wet soil or soil which has eroded into the excavation shall be removed or excavated and re-compacted prior to placing additional backfill material.
- G. Openings in structures to receive pipe shall be temporarily plugged or bulkheaded during backfill operations. Backfill shall proceed to an elevation level with the invert of the pipe. The pipe shall then be bedded and backfilled in accordance with the applicable drawing details and specifications.

5.3.2 Excavations

5.3.2.1 General

- A. The Developer's Contractor shall construct all earth excavations to the widths and depths detailed in the Utility approved project drawings. Excavation shall include all kinds of materials, wet and/or dry, excavated, or which are to be excavated, including rock, shale, hardpan, muck, quicksand, etc.
- B. Excavation includes all excavation, surface removal, clearing, disposal of surplus material, dewatering, boring and jacking, and all other work incidental to the construction of trenches or trenchless means for pipe installation. Excavation also includes the same activities related to the installation of manholes or other structures required in the Utility approved drawings.
- C. The Developer and his or her Contractor shall be responsible for assuring the protection of all existing improvements, both public and private. The Utility shall be held harmless from any and all damages to said existing improvements during the construction of the project as detailed on the Utility approved drawings.
- D. Compliance with these specifications does not eliminate the need to comply with other applicable City, County, State and Federal ordinances, regulations, and construction requirements. This includes, but is not limited to specifications as outlined by IDEM, INDOT, or other governmental agencies.
- E. The provisions of this document shall be deemed as additional requirements to minimum standards required by other applicable ordinances and standards. In the case of conflicting requirements, the most restrictive shall apply.

5.3.2.2 Execution

5.3.2.2.1 Clearing

Prior to excavation, areas within the project limits shall be first cleared of obstructions, debris, and existing facilities with the exception of facilities that must temporarily or permanently remain. The Developer's Contractor shall remove and keep separate the topsoil, and shall carefully replace it after the backfilling is completed.

5.3.2.2.2 Protection of Existing Improvements Required to Remain in Place

- A. Before any excavation is started, adequate protection shall be provided for all lawns, trees, shrubs, landscape work, fences, sidewalks, hydrants, utility poles, street, alley and driveway paving, curbs, storm sewers, ditches, headwalls, catch basins, surface inlets and all other improvements that are designated to remain in place. Such protection shall be provided as long as necessary to prevent damage from the Developer's Contractor's operations.
- B. The Developer's Contractor shall exercise every precaution to prevent damage to property within and outside the immediate vicinity of the work. The Developer's Contractor shall restore the ground surfaces, replace or repair driveways, buildings, fences, retaining walls, culverts, drains, paving, sidewalks, etc., which are removed or damaged during construction and which are designated on the plans to remain in place.

5.3.2.2.3 Pavement Removal

All pavement cutting and removal shall be performed in accordance with the requirements of the regulatory agency responsible for the maintenance of the roadway.

5.3.2.2.4 Maintenance of Roadway Access

- A. All maintenance of traffic shall be in accordance with the requirements of the regulatory agency or authority in charge of maintaining the subject roadway.
- B. The Developer's Contractor shall not close or obstruct any portion of a public street without first notifying in writing the appropriate regulatory roadway authority. The contractor should be aware that there is sufficient time allowed for the authority to review and act on the closure request.
- C. Unless closure is approved, streets, roads, private ways and walks shall be maintained passable by the developer's contractor at all times, and the contractor shall be responsible for the adequacy and safety of provisions made.
- D. To protect persons from injury and to avoid property damage, adequate barricades, construction signs, warning lights, and guards as required shall be placed and maintained during the progress of the construction work and until it is safe to use the construction area for its normal purposes.

5.3.2.2.5 Utility Protection

- A. All available information and/or written reports on subsurface exploration in the vicinity of proposed pipe line construction will be made available by the EWSU upon request. However, it is expressly understood and agreed that the EWSU shall in no way be held responsible for interpretation of this information, its accuracy, or its thoroughness. The Developer and or his Contractors shall make such subsurface explorations as they believe necessary to verify and supplement information received from the EWSU.
- B. Prior to proceeding with excavation, the Developer or his Contractor shall initiate the location of all utilities in the area to aid in locating their underground services. Upon

location of utilities, the Contractor shall use care in excavating near existing utilities in order to protect them from damage.

5.3.2.2.6 Deviations from Line and Grade Due to Unforeseen Underground Issues

Wherever obstructions are encountered during the progress of the work and interfere to such an extent that an alteration in the plan is required, the Developer's Engineer may revise the plans and request a deviation from the line and grade or arrange with the owners of the structures for the removal, relocation or reconstruction of the obstructions. Where sewer, gas, water, telephone, electrical or other existing utilities are an impediment to the vertical or horizontal alignment of the proposed pipe line, the Contractor must arrange with the conflicting utility to relocate or have the Developer's Engineer revise the drawings to avoid the conflict. All changes in the lines or grades on the plans must be approved by the EWSU prior to initiating construction.

5.3.2.2.7 Construction in Easements

In easements across private property, the Developer's Contractor shall confine all operations to the easement area. In general, the easement area is intended to provide reasonable access and working area for efficient operation by the Contractor. Where adequate easement space for efficient operation is not provided, the Developer and/or his Contractor shall adjust construction methods to complete the work within the easement or work with the EWSU to grant or acquire additional easement.

5.3.2.2.8 Maintenance of Existing Drainage Flow

The Developer's Contractor shall make provisions for handling and maintaining all flows in existing creeks, ditches, sewers and trenches by pipes, flumes or other approved methods at all times when his operations would, in any way, interfere with the natural functioning of said creeks, ditches, sewers and drains.

5.3.2.2.9 Trench Dimensions

- A. The width of trenches in earth for sewer pipe, laterals, and other structures shall provide a trench width of approximately 1.25 times the outside diameter of the pipe plus twelve (12") inches.
- B. Sidewalls of pipe trenches shall be vertical from the bottom of the trench to a point not less than twelve (12") inches above the top of the pipe. Above that point, sidewalls may be battered to such slopes as directed on the plans to maintain a safe working environment.
- C. Trench sheeting and bracing or a trench shield or box shall be used as required by the rules and regulations of OSHA. The bottom of the trench shall conform to the details shown on the approved plans.

5.3.2.2.10 Earth Excavation

- A. Earth materials shall be excavated so that the open cuts conform to the lines, grades and dimensions shown on the drawings.

- B. After the trench is excavated to grade, the Developer's Engineer shall examine the base and determine whether or not it is satisfactory for pipe laying. If the base is not satisfactory, it shall be removed and replaced with crushed stone as ordered by the Engineer. The crushed stone shall be #5 or #8 gradation as specified in INDOT Standard Specification, and extend a minimum depth of six inches (6") below the barrel of the pipe. Should the base still not be suitable for adequate support of the pipe (i.e. a boiling or quicksand condition, muck, etc.), the Contractor shall propose alternate methods of suitable construction practices to the EWSU for approval. The EWSU shall approve alternate base stabilization methods prior to commencing laying of pipe in the trench.
- C. Excavated earth materials that are suitable for backfilling may be used for backfill when allowed by the approved plans and specifications. This excavated material may only be used as final backfill in areas not subject to traffic loading and as shown on the project drawings and details.

5.3.2.2.11 Boring and Jacking

If called for on the EWSU approved drawings, boring and jacking of pipe may be required. The same standards for line and grade in open cut installations apply to boring or jacking of pipe.

5.3.2.2.12 Removal of Water

- A. The Developer's Contractor shall at all times during construction provide and maintain ample means and devices with which to remove and properly dispose of all water entering the excavations or other parts of the work and shall keep the excavations dry until the structures to be built therein are completed or connections to existing structures are completed.
- B. The Developer's Contractor shall be responsible to provide all equipment and labor to maintain bypass pumping during connections to existing structures. The Contractor shall maintain adequate pumping capacity at all times to prevent any spills, overflows, or discharges from the existing sanitary system.

5.3.3 Gravity Sanitary Sewer Pipe

5.3.3.1 General

5.3.3.1.1 Description

- A. The Contractor shall furnish and lay sewer pipe, and all accessories, to the lines and grades shown on the approved drawings. Sewer pipe shall be constructed of the pipe materials as specified herein.
- B. Related work described elsewhere:
 - Excavation
 - Embedment and Backfill

5.3.3.1.2 Quality Assurance

- A. Codes and Standards

- Each length of pipe shall be marked per the requirements of the respective ASTM Standard.
- All codes and standards shall be set forth in the latest ASTM Standard.
- Upon request by the EWSU, the Contractor shall furnish copies of all material tests required by the applicable ASTM Standard.

5.3.3.1.3 Submittals

A. Shop Drawings

- Prior to ordering pipe material, submit shop drawings to the EWSU for approval. All submittals shall include certification of conformance with the applicable ASTM Pipe Standard, allowable ASTM bedding certification, and the manufacturer's installation recommendations based upon the application. No field work shall be started prior to shop drawing approval.

5.3.3.2 Products

5.3.3.2.1 Polyvinyl Chloride (PVC) Pipe, SDR 26

A. Material

- Polyvinyl chloride (PVC) for gravity sanitary sewer pipe shall be the integral wall bell and spigot type with elastomeric seal joints and smooth inner walls meeting or exceeding all of the requirements set forth in ASTM D-3034 for SDR-26 for pipe diameters 15-inches or less.
- For diameters 15-inches or less, the pipe shall have a minimum cell classification of 12454 or 12364; with all pipe having a minimum tensile strength of 34.50 Mpa as defined in ASTM D-1784.
- PVC sanitary sewer pipe shall have a minimum pipe stiffness of 115 psi for each diameter when measured at 5% vertical ring deflection and tested in accordance with ASTM D-2412.

B. Joints

- Flexible gasket joints shall be compression type so that when assembled, the gasket inside the bell will be compressed radially on the pipe spigot to form a watertight seal. The assembly of joints shall be in accordance with the pipe manufacturer's recommendations and ASTM D-3212. The gaskets sealing the joint shall be made of rubber of special composition having a texture to assure a watertight and permanent seal and shall be the product of a manufacturer having at least five (5) years of experience in the manufacture of rubber gaskets for pipe joints. The gasket shall be a continuous ring of flexible joint rubber of a composition and texture which is resistant to common ingredients of sewage, industrial wastes and groundwater and which will endure permanently under the conditions imposed by this service. The gasket shall conform to the requirements of ASTM F-477.

- NO SOLVENT CEMENT JOINTS SHALL BE ALLOWED.
- All field-cutting of pipe shall be done in a neat manner as per manufacturer's recommendations and the cut end shall be beveled using a file or wheel to produce a smooth bevel of approximately 15° and be a minimum depth of one-third the pipe wall thickness. Field cut pipe will only be allowed to be installed at manholes, at prefabricated tees and wyes, and at the connection of new sanitary sewer to existing sanitary sewer.

C. Fittings

- All pipe fittings shall be manufactured in accordance with the latest ASTM D-3034 and ASTM F-679 Standards and shall have a minimum pipe stiffness of 115 psi in all directions. The minimum cell classification shall be 12454 or 12364 per the latest ASTM D-1784 Standard. All fittings shall be "heavy wall" and provided gaskets meeting or exceeding the standards for the pipe.
- All sewer main lateral connections shall be pre-fabricated wye fittings. All pipe fittings shall be injection molded unless prior authorization is granted by the EWSU.
- Saddle connections shall not be allowed.

D. Design

- The minimum wall thickness for PVC sewer pipe and lateral sewer pipe 15- inches or less in diameter shall conform to SDR-26 as specified in ASTM D-3034.

E. Markings

- The date of manufacture, shift code, class of pipe, ASTM specification designation ("PVC-SDR-26"), size of pipe, name or trademark of manufacturer, and identification of plant/location shall be legibly marked on the outside of each pipe section and fitting in accordance with the ASTM D-3034.

F. Certification

- The Contractor shall furnish, upon request, certified reports stating that inspection and specified tests have been made and that the results thereof comply with the applicable Standards.

5.3.3.2.2 Polyvinyl Chloride (PVC) Pipe, C-900/C-905

A. Pipe

- PVC gravity sewer main pipe shall conform to ASTM Specification D-2241, Standard Specification for Polyvinyl Chloride (PVC) Plastic Pipe (SDR PR). The material used shall conform to ASTM Specification D-1784, Standard Specification of Rigid Polyvinyl Chloride and Chlorinated Polyvinyl Chloride compounds, Class 12454. The minimum pressure class/DR rating acceptable shall be Class 150, DR 18.
- The pipe fittings shall be pressure rated in accordance with recommendations of the Plastic Pipe Institute.

- PVC gravity sewer main shall be in compliance with AWWA C-900 for 4" through 12" and AWWA C-905 for 14" and greater. The minimum dimension ratio shall be DR18 with a pressure rating of 235 psi.
- All plastic pipe and couplings shall bear identification markings in accordance with Section 2.5.2 and 2.5.3 of AWWA C-900, which shall include the National Sanitation Foundation (NSF) seal of approval. In addition, the plain end of each pipe length shall have two (2) rings, one inch (1") apart, painted around the pipe at the proper location to allow field checking of the correct setting depth of the pipe in the bell or coupling.

B. Joints

- Joints shall be bell end or coupling push-on type.
- The push-on joint and joint compounds shall meet the requirements for ASTM Specification D-3139, Joint for the Plastic Pipe, using flexible elastomeric seals. The joint shall be designed so as to provide for the thermal expansion and contraction experienced with a total temperature change of seventy-five (75) degrees F in each joint of pipe. Details of the joint design and assembly shall be in accordance with joint manufacturer's standard practice.
- The lubricant shall have no deteriorating effects on the gasket or the pipe.
- The lubricant containers shall be labeled with manufacturer's name.
- The gaskets sealing the joint shall be made of rubber of special composition having a texture to assure a watertight and permanent seal and shall be the product of a manufacturer having at least five (5) years of experience in the manufacture of rubber gaskets for pipe joints. The gasket shall be a continuous ring of flexible joint rubber of a composition and texture which is resistant to common ingredients of sewage, industrial wastes and groundwater and which will endure permanently under the conditions imposed by this service. The gasket shall conform to ASTM F-477. Gaskets shall meet all applicable requirements of ANSI Standard A- 21.11.

C. Fittings

- Fittings shall be manufactured in one piece of injection molded PVC compound meeting the requirements of ASTM D1784. Fittings shall be designed to withstand a minimum of 755 psi quick burst pressure @ 73 degrees F in accordance with ASTM D1599.
- All sewer main lateral connections shall be pre-fabricated wye fittings to fit C900 pipe. All pipe fittings shall be injection molded unless prior authorization is granted by the EWSU.

D. Markings

- The date of manufacture, shift code, class of pipe, ASTM specification designation ("PVC-C900"), size of pipe, name or trademark of manufacturer, and identification

of plant/location shall be legibly marked on the outside of each pipe section and fitting in accordance with the ASTM D-3034.

E. Certification

- The Contractor shall furnish, upon request, certified reports stating that inspection and specified tests have been made and that the results thereof comply with the applicable standards.

5.3.3.2.3 Vitrified Clay Pipe

A. Material

- VCP pipe shall be wall bell and spigot type with elastomeric seal joints, extra strength clay pipe meeting or exceeding the requirements of ASTM C-700.

B. Joints

- Joints shall be a compression type conforming in all respects to ASTM C-425 for factory made compression-type joints on vitrified clay pipe, or a factory applied PVC bell or collar securely fastened at the factory in accordance with ASTM C-425, with PVC collar meeting the requirements of ASTM D-1784.
- All field cutting of pipe shall be done in accordance with ASTM C-12 and the manufacturer's instructions.

C. Fittings

- Only factory fabricated fittings meeting the requirements of ASTM C-700 extra strength pipe and ASTM C-425, shall be used.

D. Certification

- The Contractor shall furnish, upon request, certified reports stating that inspection and specified tests have been made and that the results thereof comply with the applicable Standards.

E. Markings

- Each length of pipe and each fitting shall be legibly marked with the following:
 - Manufacturer's Name or Trademark
 - Pipe Strength
 - Pipe Size
 - Plant Identification

5.3.3.3 Execution

5.3.3.3.1 General

- A. This section on the laying of sewers shall be divided into two (2) classifications - rigid and non-rigid pipe. Vitrified clay pipe is considered as a rigid pipe. Polyvinyl Chloride (PVC), either AWWA C900/C905 or SDR 26, pipe shall be considered non-rigid or flexible conduits.

- B. All pipes shall be handled, stored and installed according to the manufacturer's recommendations.
- C. Approximate depths of existing utilities (gas, water, telephone, etc.) may be shown on the plans but should be considered as best available information unless noted as "field verified". In all instances where the drawings do not note the utility locations as "field verified", the contractor shall perform necessary field investigation to verify the vertical and horizontal location of the utilities. The contractor should anticipate a certain number of conflicts between the proposed sewer and the existing utility based on the location and size of the sewers, the number of utilities shown on the plans and previous experience.
- D. The minimum cover for sanitary sewer shall be three (3) feet. The maximum allowable depth shall be per manufacturer's recommendations and shall be based upon the bedding and backfill used for the installation.
- E. Sanitary sewers shall be constructed with a ten (10) foot minimum separation from an existing or proposed water main, measured horizontally from the outside edge of the sanitary sewer to the outside edge of the water main. A vertical separation of a minimum of eighteen (18") inches, measured vertically from the outside edge of the sanitary sewer to the outside edge of the water main, must also be maintained. When a sanitary sewer main crosses a water main, it shall cross at as nearly to ninety (90) degrees as possible but not less than forty-five (45) degrees, measured from the centerlines of the sanitary sewer and water main. No sanitary manhole shall be located within eight (8') feet of a water main, measured from the outside edge of the sanitary sewer manhole to the closest outside edge of the water main.

Where required horizontal and/or vertical separation from water lines can't be met, the sewer material shall be constructed of PVC SDR 21 or PVC AWWA C900/C905 pipe for a distance of ten (10') feet on either side of the crossing point.

- F. All pipe shall be constructed beginning from the lowest point and shall begin at either a new structure or connection to an existing structure. Construction shall proceed to the lines and grades shown on the approved drawings. Line and grade between manholes shall be maintained by use of laser.
- G. The Contractor shall verify the initial starting elevation from at least two (2) established benchmarks.

5.3.3.3.2 Rigid Pipe Installation (Vitrified Clay Pipe)

- A. All rigid pipes shall be laid to the lines and grades shown on the plans. Vitrified pipe shall be installed per ASTM C 12, Standard Practice for Installing Vitrified Clay Pipe Lines.
- B. All rigid pipes shall be laid, bedded, haunched, and backfilled in accordance with Standard Detail WW-13 for pipes constructed under or within five (5') feet of pavement. Any portion of the backfill that is below the zone of influence of traffic as detailed in Standard Detail WW-21 shall be performed according to WW-13. Embedment and backfill materials and installation shall be per Standard Specification for "Embedment and Backfill"

- C. All rigid pipes shall be laid, bedded, haunched and backfilled in accordance with Standard Detail WW-14 for pipes constructed outside of five (5') feet of the edge of pavement or not under the influence of traffic load. Standard Detail WW-21 shows the zone of influence of traffic for reference. All embedment and backfill materials and installation shall be per Standard Specification for "Embedment and Backfill".
- D. The laying of pipe in finished trenches shall be commenced at the lowest point, proceeding upstream, with the spigot ends pointing the direction of flow.
- E. Except as otherwise specified, the excavation work for the sewer trench shall be performed in accordance with the specification for "Excavation".
- F. The practice of blocking pipe up to grade with bedding material, then backfilling under is prohibited. The entire length of the bed section is to be at proper grade before installing pipe.
- G. All pipes and fittings shall be carefully inspected before being laid, and no cracked, broken or defective pipe or fitting shall be used in the work. All pipe shall be carefully inserted in the bell in such a manner that there will be no unevenness of any kind along the bottom half of the pipes and so that there is a uniform joint space all around.
- H. All pipe that is field cut shall have the homing-marks reestablished, insuring for proper seating depths. Pipes that are field cut shall have the cut ends re-tapered, by grinding or filing, as close to the original taper provided by the manufacturer as possible. When homing pipe, other than by hand, place a piece of wood between pipe and tool to prevent damage to bell end-section.
- I. Pipe laid in open cut shall have all trench spaces and voids solidly and completely backfilled according to the Specification for "Embedment and Backfill".
- J. The joints shall be constructed as specified. The interior of the sewer shall, as the work progresses, be cleared of all dirt and superfluous materials of every description. Whenever pipe laying is discontinued, the unfinished end of the sewer shall be protected from displacement and cave-in or other injuries. During the process of the laying, care shall be taken to protect both pipes and joints from disturbance, and the trench shall be kept free from water until the joints shall have set. All surplus mortar or debris shall be promptly and completely removed from the interior of the pipes. On sewers twenty-four (24) inches in diameter and less, a disc mold or swab attached to a rod sufficiently long to pass two (2) joints from the end of the pipe last laid, shall be continuously worked through as the laying of the pipe proceeds.
- K. The ends of the pipes shall be protected to prevent the entrance of dirt or other foreign substances. Such protection shall be placed at night or whenever pipe laying is stopped for any reason. Suitable plugs designed for use with the pipe material shall be provided and properly secured and used to cap all slants and branches. Pipe end protection and devices shall be included in the prices bid per linear foot of sewer.

5.3.3.3.3 Flexible Pipe Installation (PVC C900 or PVC SDR 26)

- A. Plastic sewer pipe (PVC) and other flexible pipe shall be carefully installed in accordance with the above specification for Rigid Conduit Installation, except where the following paragraphs modify those specifications.
- B. Flexible conduit for sewer pipe shall be installed in accordance with "Underground installation of Flexible Thermoplastic Pipe for Sewers and Other Gravity Flow Applications" ASTM D 2321.
- C. All flexible pipes shall be laid, bedded, haunched and backfilled in accordance with Standard Detail WW-15 for pipes constructed under or within five (5') feet of pavement or below the zone of influence of traffic as detailed in Standard Detail WW-21. All embedment and backfill materials and installation shall be per the Standard Specification for "Embedment and Backfill".
- D. All flexible pipes shall be laid, bedded, haunched and backfilled in accordance with Standard Detail WW-16 for pipes constructed outside of five (5') feet of the edge of pavement or not under the influence of traffic load. Standard Detail WW-21 shows the zone of influence of traffic for reference. All embedment and backfill materials and installation shall be per Standard Specification for "Embedment and Backfill".
- E. Compaction of bedding, haunching, and initial backfill is essential to maintain the structure and grade of flexible pipe and shall be specifically adhered to.

5.3.3.3.4 Testing Gravity Sanitary Sewers General

- A. Once constructed, all sanitary sewers and manholes shall be watertight and free from leakage. The Contractor shall be required to repair all visible leaks.
- B. Any leakage found during the infiltration test shall be corrected prior to acceptance. Grouting of the joint or crack to repair the leakage shall not be permitted for flexible pipe. If the defective portion of the sanitary sewer cannot be located, the Contractor shall remove and reconstruct as much of the work as is necessary to obtain a system that passes infiltration requirements.
- C. All gravity sanitary sewers constructed of flexible pipe shall be deflection tested no sooner than thirty (30) days after installation and complete backfill.
- D. The Contractor shall supply all equipment necessary to perform the tests required.
- E. All tests shall be conducted under the observation of a representative of the EWSU. It shall be the Contractor's responsibility to schedule testing.

5.3.3.3.5 Low Pressure Air Test (All Approved Gravity Sanitary Sewer Pipe Materials)

All gravity sanitary sewers shall be tested for infiltration by means of a low pressure air test as generally described herein. Any other infiltration test procedure will only be allowed following the submittal of the procedure to the EWSU for review and consideration.

A. Equipment

- The Contractor shall be responsible for providing all equipment and supplies necessary for the performance of a Low Pressure Air Test including but not limited to the following:
 - Pneumatic Plugs
 - Air Control Panel
 - Shut-Off Valve, Pressure Regulative Valve, Pressure Relief Valve and Input Pressure Gauge — The pressure regulator or relief valve set shall be set no higher than 10 psig to avoid over pressurization
 - Continuous monitoring pressure gauge having a range of 0 to 10 psi The gauge shall be no less than 4 inches in diameter with minimum divisions of 0.10 psi and an accuracy of ± 0.04 psi.
- To reduce the potential for sewer line over-pressurization, two (2) separate hoses shall be used to: connect the control panel to the sealed line for introducing low pressure air, and a separate hose connection for constant monitoring of air pressure buildup in the line.
- If pneumatic plugs are utilized, a separate hose shall be required to inflate the pneumatic plugs.

B. Groundwater Elevation and Air Pressure Adjustment

- Groundwater monitoring methods shall require the approval of the EWSU. Groundwater depth shall be determined in the field by the Contractor.
- Air Pressure Adjustment

The air pressure correction, which must be added to the 3.5 psig normal test starting pressure, shall be calculated by dividing the average vertical height, in feet of groundwater above the invert of the sewer pipe to be tested. The results give the air pressure correction in pounds per square inch to be added.

The allowable pressure drop of 1.0 psig and the timing in Table 1 are not affected and shall remain the same.

- Maximum Test Pressure
 - In no case should the starting test pressure exceed 9.0 psig. If the average vertical height of groundwater above the pipe invert is more than 12.7 feet, the section so submerged may be tested using 9.0 psig as the starting test pressure. The 9 psig limit is intended to further ensure workman safety and falls within the range of the pressure monitoring gauges normally used.

C. Test Procedure

Following are general procedures to be employed in the performance of the test.

- Plug Installation and Testing

- After a segment of pipe has been backfilled to final grade, prepared for testing, and the specified waiting period has elapsed, the plugs shall be securely placed in the line at the ends of each segment to be tested.
- The Contractor shall seal test all plugs before use. Seal testing may be accomplished by laying one length of pipe on the ground and sealing it at both ends with the plugs to be checked. The sealed pipe should be pressurized to 9 psig. The plugs shall hold against this pressure without bracing and without any movement of the plugs out of the pipe.
- The Contractor shall plug the upstream end of the line first to prevent any upstream water from collecting in the test line. This is particularly important in high groundwater situations. When plugs are being placed, the pipe adjacent to the manhole shall be visually inspected to detect any evidence of shear in the pipe due to differential settlement between the pipe and the manhole. A probable point of leakage is at the junction of the manhole and the pipe. This fault may be covered by the pipe plug and thus not revealed by the air test.

D. Line Pressurization

Low pressure air shall be slowly introduced into the sealed line until the internal air pressure reaches the “starting air pressure” of 4.0 psig greater than the average back pressure of any groundwater above the pipe, but not greater than 9.0 psig.

E. Pressure Stabilization

After the starting air pressure is reached, the air supply shall be throttled to maintain that internal pressure for at least 2 minutes. This time permits the temperature of the entering air to equalize with the temperature of the pipe wall.

F. Timing Pressure Loss

When temperatures have been equalized and the starting pressure stabilized, the air hose from the control panel to the air supply shall be shut off or disconnected. The continuous monitoring pressure gauge shall then be observed while the pressure is decreased to no less than 0.5 psig from the starting air pressure. At a convenient reading of 0.5 psig less than starting air pressure, timing shall commence with a stop watch.

A predetermined required time for a specified pressure drop shall be used to determine the lines acceptability. A pressure drop of

1.0 psig shall be used.

G. Determination of Line Acceptance

If the time shown in Table 1, for the designated pipe size and length elapses before the air pressure drops 1.0 psig, the section undergoing test shall have passed and shall be presumed to be free of defects. The test may be discontinued once the prescribed time has elapsed even though the 1.0 psig drop has not occurred.

H. Determination of Line Failure

If the pressure drops 1.0 psig before the appropriate time shown in Table 1 has elapsed, the air loss rate shall be considered excessive and the section of pipe shall be determined to have failed the test.

I. Testing Main Sewers with Laterals

In general, the EWSU will only approve the construction of the main line sewer and wye connections with the lateral stubbed-off to the property line. Private sewer lateral connections shall not be made to the lateral prior to the project passing all testing.

J. Specified Time Tables

To facilitate the proper use of this recommended practice for air testing, Table 1 is provided. Table 5.1 contains the specified minimum times required for a 1.0 psig pressure drop from a starting pressure of at least 3.5 psig greater than the average back pressure of any groundwater above the pipe's invert.

5.3.3.3.6 Deflection Test for Flexible Pipe

Maximum ring deflection of the pipe line under load shall be limited to 5% of the vertical internal pipe diameter. The Contractor shall provide a proving ring that is ASTM certified to within 5% of the nominal diameter of the pipe installed on the project.

A representative of the EWSU must be present during the deflection testing. It is the responsibility of the Contractor to provide sufficient notice to the EWSU so that testing can be witnessed.

All flexible pipes shall be mandrel tested with a rigid device sized to pass five percent (5%) or less vertical deflection (or deformation) of the base inside diameter of the pipe. The mandrel test shall be conducted no earlier than thirty (30) days after reaching final trench backfill grade.

Each pipe material/type required to be Mandrel tested shall be tested with a mandrel approved by the pipe manufacturer and meeting the requirements of this Section.

The mandrel shall be pulled by hand through all sewer lines in a manner acceptable to the EWSU and any section of sewer not passing the mandrel shall be uncovered, replaced or repaired to the satisfaction of the EWSU and retested.

The Contractor shall provide proving rings to check the mandrel. Drawings of mandrels with complete dimensions shall be furnished to the EWSU upon request for each diameter and specification type. The EWSU reserves the right to check the mandrel for proper size.

**SPECIFICATION TIME REQUIRED FOR A 1.0 PSIG PRESSURE DROP
FOR SIZE AND LENGTH OF PIPE INDICATED FOR Q = 0.0015**

Pipe Dia. (in)	Min. Time (min:sec)	Length for Min. Time (ft)	Time for Longer Length (sec/ft)	Specification Time for Length (L) Shown (min:sec)							
				100 ft	150 ft	200 ft	250 ft	300 ft	350 ft	400 ft	450 ft
4	3:46	597	0.380	3:46	3:46	3:46	3:46	3:46	3:46	3:46	3:46
6	5:40	398	0.854	5:40	5:40	5:40	5:40	5:40	5:40	5:42	6:24
8	7:34	298	1.520	7:34	7:34	7:34	7:34	7:36	8:52	10:08	11:24
10	9:26	239	2.374	9:26	9:26	9:26	9:53	11:52	13:51	15:49	17:48
12	11:20	199	3.418	11:20	11:20	11:24	14:15	17:05	19:56	22:47	25:38
15	14:10	159	5.342	14:10	14:10	17:48	22:15	26:42	31:09	35:36	40:04
18	17:00	133	7.692	17:00	19:13	25:38	32:03	38:27	44:52	51:16	57:41
21	19:50	114	10.470	19:50	26:10	34:54	43:37	52:21	61:00	69:48	78:31
24	22:40	99	13.674	22:47	34:11	45:34	56:58	68:22	79:46	91:10	102:33
27	25:30	88	17.306	28:51	43:16	57:41	72:07	86:32	100:57	115:22	129:48
30	28:20	80	21.366	35:37	53:25	71:13	89:02	106:50	124:38	142:26	160:15
33	31:10	72	25.852	43:05	64:38	86:10	107:43	129:16	150:43	172:21	193:53
36	34:00	66	30.768	51:17	76:55	102:34	128:12	153:50	179:29	205:07	230:46
42	39:48	57	41.883	69:48	104:42	139:37	174:30	209:24	244:19	279:13	314:07
48	45:34	50	54.705	91:10	136:45	182:21	227:55	273:31	319:06	364:42	410:17

TABLE 5-1: TIME REQUIRED FOR A 1.0 PSIG PRESSURE DROP FOR AIR TESTING PIPE

5.3.4 Standard Manholes

5.3.4.1 General

5.3.4.1.1 Description

- A. Standard manholes shall be constructed complete, ready for use, including excavation, backfill, concrete work, cast iron frames and covers, and pertinent work as shown on the Utility approved drawings. All manholes shall be made watertight, and the Developer and his or her Contractor shall furnish all materials and perform all work necessary for watertight construction.
- B. All proposed castings set in paved areas shall be flush with the final pavement elevations. All proposed castings to be set in non-paved areas shall stand approximately two (2) inches above flush with the final ground elevations or to the elevation detailed on the Utility approved drawings.

5.3.4.1.2 Related Specifications

- A. Comply with applicable portions of the following Specifications:
 - Excavation
 - Embedment and Backfill

5.3.4.2 Products

5.3.4.2.1 Reinforced Concrete Manholes and Accessories

- A. Manholes shall be constructed in accordance with the ASTM C478, Standard Specifications for Precast Reinforced Concrete Manhole Sections. The minimum wall thickness shall be five (5) inches for manholes four (4) feet in diameter.
- B. The precast tops shall be of the eccentric cone type. Precast flat covers shall be not less than eight (8) inches thick and reinforced with two layers of steel with a minimum area of 0.39 square inches per linear foot in both directions in each layer. Precast flat bottoms of manholes shall also be reinforced the same as specified herein for precast flat top. Hoisting lugs or hooks shall be cast in place for handling and setting of the rings. Openings of proper sizes and suitable design shall be cast in place for receiving the sewer and/or drop pipes and connections. Adjusting riser rings shall be provided.
- C. All manhole joints shall be tongue and groove and they shall be sealed with 1-1/4" butyl mastic joint sealant meeting ASTM C-990. Cracked or damaged barrel joints shall not be allowed. All joints shall also have an exterior joint wrap meeting ASTM C-877. The joint wrap shall be a minimum of six (6") inches in width. For all joint wrap, the exterior surface of the manhole shall be primed with bituminous primer prior to wrapping. In all instances where a joint is below the water table, the joint shall be sealed with a controlled expansion water seal equal to Conseal CS-231. It is acceptable to use CS-231 for all joints. No interior or exterior grouting of the joints is required.
- D. Manhole steps shall not be installed on sanitary sewer manholes.

- E. Manhole bases shall be of cast-in-place monolithic concrete or precast concrete. Where sewer lines pass through or enter manholes, the invert channels shall be smooth and semi-circular in cross section with the wall extending to full depth elevation of the pipe. The invert channels shall be formed directly in the concrete of the manhole base. Changes of direction of flow within the manholes shall be made with a smooth curve with as long as a radius as possible. The walls of the channels may be flared out to allow testing equipment to be inserted and removed. The floor of the manhole outside the channels shall be smooth and slope toward the channel not less than one (1) inch per foot.
- F. For cast in place bases, no mortar or concrete shall be placed in water, and no water shall be allowed to flow over or against the concrete before it has had adequate time to set in order to prevent damage to the structure.
- G. The standard manhole is forty-eight (48") in diameter. Larger diameter manholes may be required in instances with large pipe diameters or with certain internal drops, if approved. Manhole barrel sections shall be in one, two, three, or four foot sections. The cone section shall be of the eccentric cone type, two or three feet in length.
- H. Adjusting Rings. Where one (1) solid riser or barrel section cannot be used, final adjustments in elevation of the frame and cover shall only be accomplished by the use of precast concrete adjusting rings conforming to ASTM C 478. Rings shall be of a nominal thicknesses of three (3"), four (4"), or six (6") inches. Not more than two (2) rings and not more than twelve (12) inches total of adjusting rings shall be allowed for adjustment of the manhole frame and cover to required elevation. Grade ring joints shall have a 1 ¼" thick preformed butyl rubber flexible sealant conforming to ASTM C990. Adjusting rings shall contain a waterproofing additive, XYPEX or equivalent.
- I. All precast concrete for manholes shall contain waterproofing additive, XYPEX or equivalent. All precast concrete for new manholes that will be receiving a force main or are within five hundred (500') feet upstream or downstream of the receiving manhole shall contain anti-corrosion additive conforming to Conshield or equivalent. The amounts of additive shall be per manufacturer's recommendation.

5.3.4.2.2 Sewer Pipe to Manhole Connections

- A. To connect a sanitary sewer to a manhole, a resilient pipe to manhole connector shall be used meeting the requirements of ASTM C-923. Either a flexible boot KOR-N-SEAL 1 or 2, cast-in-place Dura-Seal gasket, "A"-lock gasket or an approved equal shall be used. Connections to an existing manhole shall be a flexible boot seal.
- B. If the flexible boot connection is used, it shall be placed in the reinforced concrete manhole base and secured to the pipe by a stainless steel clamp. Flexible connectors shall conform to ASTM C 923.

- C. All connections shall provide for a watertight seal between the pipe and manhole. The connector shall be the sole element relied upon to assure a flexible watertight seal of the pipe to the manhole.
- D. The invert of the connection shall be grouted with non-shrink grout. The remainder of the resilient connection shall be free of grout to promote flexibility of the connection.
- E. The rubber for the connector shall conform to ASTM C 923 and shall be resistant to ozone, weather elements, chemicals, including acids and alkalis, animal and vegetable fats, oils and petroleum products.
- F. The stainless steel elements of the connector shall be totally non-magnetic Series 305 stainless steel. The stainless steel clamp shall be capable of sustaining applied torque in excess of eighty (80) inch-pounds.
- G. New connections made to any existing structure shall be drilled in the direction of flow. The internal base material shall be removed and re-poured with the channels meeting the requirements of the manhole base section. If the structural integrity of the concrete base section is compromised during the removal of the interior base, the entire base section shall be replaced. The connector boot shall be appropriately sized to fit the opening and shall be KOR-N-SEAL® by NPC, Inc., A-Lok Products, Inc., or approved equal.

5.3.4.2.3 Castings

- A. Standard manholes shall have a 1022-3 by East Jordan Iron Works, or approved equal casting. Material shall be in compliance with ASTM A-48, CL 35. Each lid shall have "Sanitary Sewer" molded into the exterior surface.
 - In areas subject to traffic, the frame shall be seven (7") inches minimum height, heavy duty cover, with machined bearing surface and concealed lift holes.
 - In areas not subject to traffic, the frame shall be seven (7") inches minimum height, equal to East Jordan 1022-1 with medium duty cover and machined bearing surface with concealed lift holes.
- B. Where watertight castings are required, the manholes shall have a 1022-WT casting by East Jordan Iron Works, or approved equal. The frame shall be anchored through the riser rings (if provided) to the cone section with four (4) galvanized rods.

5.3.4.2.4 Frame Chimney Seal

- A. The section of the manhole from the eccentric cone to the casting frame shall be sealed in the same manner as barrel section joints of the manhole.
- B. The area between the casting frame and grade ring and between each grade ring shall be sealed with a 1-1/4" preformed butyl mastic sealant meeting ASTM C990. The exterior of the grade rings shall be primed with bituminous primer prior to wrapping. Each grade ring joint shall be wrapped on the exterior with joint wrap meeting the requirements of ASTM C-877.
- C. No grouting of the interior or exterior of the joint will be required.

5.3.4.3 Execution

5.3.4.3.1 Installation

- A. All manholes shall be installed so that the top of the inlet casting and frame (at the lowest point where surface water can enter) is flush with the final ground elevation. In areas not subject to traffic, the lid shall be set at two (2") inches above the surrounding surface after earth settlement.
- B. All structures shall be bedded on a minimum of six (6") inches of compacted aggregate meeting the gradation of #5 or #8 crushed stone per INDOT Standard Specifications. No structure shall be set on soft or yielding soils. If yielding soils are encountered, the area shall be excavated and filled with compacted crushed stone.
- C. All lift holes in precast sections shall be wetted and completely filled with non-shrink grout, smoothed and coated with bituminous waterproofing material to ensure water tightness.

5.3.4.4 Sanitary Manhole Testing

5.3.4.4.1 Vacuum Testing

- A. All manhole vacuum tests shall be conducted in the presence of a representative of the EWSU and in accordance with ASTM C1244, Standard Test Method for concrete Sewer Manholes by Negative Air Pressure (vacuum) Test.
- B. The vacuum test equipment shall consist of: inflatable plugs for all incoming and outgoing sewer lines; an inflatable test collar to seal the manhole at the manhole frame; and a vacuum pump. A vacuum liquid filled gauge shall be located in-line between the test collar and the pump to accurately indicate the vacuum in inches of mercury within the manhole. The vacuum gauge shall have a minimum of 3.5 inch diameter face and a range to no more than thirty (30) inches of mercury, with scale markings of no greater than one-half (1/2) inch of mercury vacuum and an accuracy to within \pm two percent (2%) of true vacuum.
- C. Preparation
 - Manholes shall be tested after installation with all connections in place.
 - Lift holes shall be filled with non-shrink grout, sealed and cured.
 - Manhole vacuum testing shall be performed after all adjacent underground utilities have been installed and all manholes have been completely backfilled and finished to grade. Vacuum testing prior to installation of all utilities may be considered upon request to the EWSU prior to installation of all utilities if the manholes are completely backfilled and sewer leakage and deflection testing is complete. If vacuum testing is performed prior to all utilities being installed and any manholes are found to have been disturbed or damaged during inspection during the warranty period, the manholes shall be repaired and vacuum tested again to ensure that there is no leakage.

- If a coating or lining is to be applied to the interior of the manhole, the test must not be performed until the coating is cured per manufacturer’s recommendation.
- D. The vacuum test shall be conducted by plugging all incoming and outgoing sewer lines in the manhole at a location beyond the connection of the sewer pipe with the manhole. All plugs shall be blocked in place so as not to move during the test. The vacuum testing collar shall be inflated in the frame in accordance with the equipment manufacturer’s recommendations. A vacuum of ten (10) inches of mercury shall be drawn and the vacuum pump turned off and the valve between the vacuum pump and the vacuum gauge shall be turned off.
- E. The time period which is taken for the vacuum to fall from ten inches (10") of mercury to nine inches (9") of mercury shall be determined. If the time taken for the vacuum to reduce the ten inches (10") of mercury to nine inches (9") of mercury is less than the time indicated in the following Table, then the manhole work shall be considered not acceptable and shall be rejected. If the time is equal to or exceeds the time indicated below, the manhole work shall be accepted.

TABLE 5-2: TIME REQUIRED TO MAINTAIN VACUUM IN MANHOLE

Manhole Depth (ft.)	Diameter =	TIME (SEC)		
		48"	60"	72"
6 feet or less		30	30	30
>6 feet to 8 feet		40	40	40
>8 feet to 10 feet		50	50	50
>10 feet to 12 feet		60	60	60
>12 feet to 14 feet		70	70	70
>14 to 16 feet		70	70	70
>16 to 18 feet		80	80	80
>18 feet to 20 feet		90	90	90
>20 feet to 22 feet		100	100	100
>22 feet to 24 feet		110	110	110
>24 feet to 26 feet		120	120	120
>26 feet to 28 feet		130	130	130
>28 feet to 30 feet		140	140	140
30+ feet		5 per foot	5 per foot	5 per foot

- F. Contractor shall submit to the EWSU the results of each manhole vacuum test. Such reports shall include a description of the location of the manhole, the time, date and weather of the test, a list of all persons present, the diameter and depth of the manhole and the allowable test results, and the actual test results.

- G. All manholes shall be repaired by Contractor and retested as described above until a successful test is made. After each test, the temporary plugs shall be removed.

5.3.4.5 Final Acceptance

Once all manholes have been tested, the manholes will be given a field visual inspection. The inspection shall be performed at the discretion of the EWSU during the warranty period. All leakage problems determined by this inspection shall be corrected by the Contractor within an agreed upon time to the satisfaction of the EWSU. Where necessary to complete the work, the Contractor shall be responsible for the bypassing and/or blocking of the flow in the manholes and must have prior approval by the EWSU.

5.3.5 Pressure Pipe - Sanitary

5.3.5.1 General

5.3.5.1.1 Description

- A. The Contractor shall furnish and lay, as required, sanitary pressure pipe, together with all fittings, thrust blocking or other incidentals as shown on the approved plans or specified and, necessary to complete the work. Sanitary pressure pipe shall be constructed of the pipe materials as specified herein.
- B. All sanitary pressure pipes to be furnished under this Contract shall conform to specifications of this section.
- C. Related work described elsewhere:
- Excavation
 - Embedment and Backfill

5.3.5.1.2 Quality Assurance

- A. Codes and Standards
- Each length of pipe shall be marked per the requirements of the respective ASTM Standard.
 - All codes and standards shall be set forth in the latest ASTM Standard.
 - Upon request by the Engineer, the Contractor shall furnish copies of all material tests required by the applicable ASTM Standard.

5.3.5.1.3 Submittals

- A. Shop Drawings
- Prior to ordering pipe material, submit shop drawings to the EWSU for approval. All submittals shall include certification of conformance with the applicable ASTM Pipe Standard, allowable ASTM bedding certification, and the manufacturer's installation recommendations based upon the application. No field work shall be started prior to shop drawing approval.

5.3.5.2 Products

5.3.5.2.1 Ductile Iron Pipe

A. Material

Ductile Iron Pipe shall be centrifugally cast and shall conform to ANSI Specifications A-21 and AWWA C-151, latest revision. Ductile Iron Pipe shall be Pressure Class 350, 300 or 250.

B. Coatings and Linings

Pipe shall be sulphate resisting cement lined in accordance with AWWA C-104. The pipe shall be seal coated with an approved bituminous seal coat in accordance with AWWA Specification C-151 (ANSI A21).

The pipe shall also have either of the following interior coatings:

- Polyurethane in accordance with ASTM D16 Type V (1000 microns minimum thickness)
- Epoxy (40 mils minimum thickness)
- Polyethylene (1500 microns minimum thickness)

C. Fittings

Fittings shall be standardized for the type of pipe and joint specified and shall comply with AWWA C-110 (ANSI A-21) or AWWA C-153 (ANSI A-21).

D. Joints

Mechanical joints or slip joints shall be provided

Mechanical joints and accessories shall conform to AWWA Standard C-111, ANSI A-21. The bolts and nuts shall be corrosion resistant high strength alloy steel.

The O-ring gaskets sealing the slip joint shall be made of rubber of special composition having a texture to assure a watertight and permanent seal and shall be the product of a manufacturer having at least five (5) years of experience in the manufacturer of rubber gaskets for pipe joints. The gasket shall be a continuous ring of flexible joint rubber of a composition and texture which is resistant to common ingredients of sewage, industrial wastes and groundwater; and which will endure permanently under the conditions likely to be imposed by this service. The gasket shall conform to the requirements of AWWA C-111 (ANSI A-2111).

Where indicated on plans, restrained joint pipe shall be provided. Restrained joints shall be designed in accordance with AWWA C-111 and shall permit horizontal and/or vertical deflection after assembly, yet adequately restrain the joint at the full design pressure.

E. Markings

The class designations for the various classes of pipe and fittings, manufacturer's name and the year of manufacture shall be cast onto fittings in raised numerals, and cast or stamped on the outside of each joint of pipe.

F. Certification

The Contractor shall furnish, upon request, certified reports stating that inspection and specified tests have been made and that the results thereof comply with the applicable standards.

5.3.5.2.2 Polyvinyl Chloride Pipe (PVC) C-900/C-905

A. Pipe

- PVC force main pipe material shall conform to ASTM Specification D-1784, Standard Specification of Rigid Polyvinyl Chloride and Chlorinated Polyvinyl Chloride compounds, Cell Class 12454 (PVC 1120). The minimum pressure class/SDR rating acceptable shall be Class 150/DR18.
- PVC force main shall be in compliance with AWWA C-900 for 4" through 12" and AWWA C-905 for 14" and greater. The minimum dimension ratio shall be DR18 with a pressure rating of 235 psi.

All plastic pipe and couplings shall bear identification markings in accordance with Section 2.5.2 and 2.5.3 of AWWA C-900, which shall include the National Sanitation Foundation (NSF) seal of approval. In addition, the plain end of each pipe length shall have two (2) rings, one inch (1") apart, painted around the pipe at the proper location to allow field checking of the correct setting depth of the pipe in the bell or coupling.

B. Joints

- Joints shall be bell end or coupling push-on type.
- The push-on joint and joint compounds shall meet the requirements for ASTM Specification D-3139, Joint for the Plastic Pipe, using flexible elastomeric seals. The joint shall be designed so as to provide for the thermal expansion and contraction experienced with a total temperature change of seventy-five (75) degrees F in each joint of pipe. Details of the joint design and assembly shall be in accordance with joint manufacturer's standard practice.

- The lubricant shall have no deteriorating effects on the gasket or the pipe.

The lubricant containers shall be labeled with manufacturer's name.

- The gaskets sealing the joint shall be made of rubber of special composition having a texture to assure a watertight and permanent seal and shall be the product of a manufacturer having at least five (5) years of experience in the manufacture of rubber gaskets for pipe joints. The gasket shall be a continuous ring of flexible joint

rubber of a composition and texture which is resistant to common ingredients of sewage, industrial wastes and groundwater and which will endure permanently under the conditions imposed by this service. The gasket shall conform to ASTM F-477. Gaskets shall meet all applicable requirements of ANSI Standard A- 21.11.

C. Fittings

Iron fittings shall be in compliance with Section 2.01.C of these specifications with joints and gaskets to properly fit the PVC pipe for 4" and larger.

D. Locating Tracing Wire

- All PVC pipe for pressure sanitary sewer shall be installed with tracing wire. Tracing wire shall be 12 AWG – solid core RHW or RHH underground copper cable. It shall be polyethylene insulated for underground service, solid copper or copper clad steel. Wire insulation shall be highly resistant to alkalis, acid and other destructive agents found in soil.
- Locating tracer wire shall be brought to service no less than every 800 L.F. on PVC riser and cap.

E. Markings

The date of manufacture, shift code, class of pipe, ASTM specification designation ("PVC-C900"), size of pipe, name or trademark of manufacturer, and identification of plant/location shall be legibly marked on the outside of each pipe section in accordance with the ASTM D-3034.

F. Certification

The Contractor shall furnish, upon request, certified reports stating that inspection and specified tests have been made and that the results thereof comply with the applicable standards.

5.3.5.2.3 Air Release Valves

- A. Air release valves shall be combination air release valves. The valve shall allow air to escape out of the large orifice when air is present and close when liquid enters the valve. When the valve is closed and pressurized, the small air release orifice will open to allow small pockets of air to escape automatically and independently of the large orifice. The large orifice shall also allow air to enter to break vacuum. The body inlet shall be baffled to protect the float from direct forces of rushing air and water to prevent premature valve shut-off.
- B. Materials shall conform to the following:
- Body and Cover: Ductile iron (ASTM A536 GR 65-45-12)
 - Float: Stainless steel (ASTM A240)
 - Needle & seat: Buna-N

- Plug: Stainless steel (ASTM A276)
- Leverage frame: Delrin/Cast Iron (ASTM D4184/ASTM A126 GR. B)

5.3.5.3 Execution

Pressure sewer mains shall be installed in accordance with AWWA/ASTM D-2774 standards and manufacturer's recommendations. If any conflict between these standards and manufacturer's recommendations, the manufacturer's recommendations shall take precedence.

5.3.5.3.1 Alignment and Grade

The pressure sewer mains shall be laid and maintained to lines and grades established by the plans and specifications, with fittings and valves at the required locations. Valve operating stems shall be oriented in a manner to allow proper operation.

A. Clearance

When crossing existing pipelines or other structures, alignment and grade may be adjusted as necessary, to provide clearance as required by federal, state, and local regulations and to prevent future damage or contamination of either the pipelines or structures. Horizontal separation from water mains shall be 10' measured horizontally from outside edge of water main to the outside edge of the proposed pressure sewer. When installation closer than ten (10') feet is required or when crossing water mains the pressure sewer main shall be installed at least eighteen (18") inches below the bottom of the water main.

B. Depth

The minimum cover for sanitary sewer shall be three (3) feet. The maximum allowable depth shall be per manufacturer's recommendations and shall be based upon the bedding and backfill used for the installation.

5.3.5.3.2 Trenching

A. General

Excavation and trenching shall be performed according to the Specification for "Excavation".

B. Rock Conditions

- When excavation of rock is encountered, all rock shall be removed to provide a clearance below and on each side of all pipe, valves, and fittings of at least 6" for pipe sizes 24" or smaller and 9" for pipe sizes 30" and larger. When excavation is completed, a layer of appropriate backfill material shall be placed on the bottom of the trench to the previously mentioned depths, leveled, and tamped.
- This installation procedure shall be followed when gravel formations containing loose boulders greater than approximately 8" (200 mm) in diameter are encountered.

- In all cases, the specified clearances shall be maintained between the bottom of all pipe and appurtenances and any part, projection, or point or rock, boulder, or stone of sufficient size and placement that, could cause a fulcrum point or point load.

5.3.5.3.3 Pipe Laying

All pipe, fittings and valves shall be lowered carefully into the trench in such a manner as to prevent damage to water main materials and protective coatings and linings. Under no circumstances shall pressure sewer main materials be dropped or dumped into the trench. Where practical, the trench should be dewatered prior to installation of the pipe.

A. Examination of Material

All pipe, fittings and valves and other appurtenances shall be examined carefully for damage and other defects immediately before installation.

B. Pipe Ends

All lumps, blisters, and excess coating shall be removed from the socket and plain ends of each pipe, and the outside of the plain end and the inside of the bell shall be wiped clean and dry and be free from dirt, sand, grit or any foreign materials before the pipe is laid.

C. Pipe Cleanliness

Foreign material shall be prevented from entering the pipe while it is being placed in the trench.

D. Pipe Placement

As each length of pipe is placed in the trench, the joint shall be assembled and the pipe brought to correct line and grade. The pipe shall be secured in place with specified backfill material. Embedment and backfill of pressure pipe shall be per Standard Specification for "Embedment and Backfill".

E. Pipe Plugs

- At times when pipe-laying is not in progress, the open ends of pipe shall be closed by a watertight plug or other means approved by the Engineer. The plug shall be fitted with a means for venting. When practical, the plug shall remain in place until the trench is pumped completely dry. Care must be taken to prevent pipe flotation, should the trench fill with water.
- Prior to removal of the plug for extending the line or for any other reason, air and/or water pressure in the line shall be released.

F. Ductile Iron Encasement

Polyethylene encasement for ductile iron pipe shall be installed in accordance with ANSI/AWWA C105/A21.5.

5.3.5.3.4 Joint Assembly

Joints shall be assembled in accordance with the manufacturer's instructions.

A. Assembly

After placing a length of pipe in the trench, the manufacturer's lubricant shall be properly applied. Spigot end shall then be centered in the bell and the pipe pushed home and brought to correct line and grade. Pipe and fittings which do not allow a sufficient and uniform space for joints shall be removed and replaced with pipe of proper dimensions to insure such uniform space. Precautions shall be taken to prevent dirt from entering the joint space.

B. Pipe Cutting

- Cutting pipe for insertion of valves, fittings, or closure pieces shall be done in conformance recommendations of the manufacturer of the cutting equipment. Cutting shall be done in a safe, workmanlike manner without creating damage to the pipe lining. An oxyacetylene torch shall not be used.
- Cut ends and rough edges shall be ground smooth, and for push-on joint connections the cut end shall be beveled by methods recommended by the manufacturer.

5.3.5.3.5 Embedment and Backfill for Pressure Sewer Main

- A. Bedding, haunching, and backfill of sewer pressure pipe shall be performed according to Standard Detail WW-15 for areas under or within five (5') feet of pavement or within the zone of influence of traffic. The zone of influence of traffic is as detailed in Standard Detail WW-21.

Bedding, haunching, and backfill of sewer pressure pipe shall be performed according to Standard Detail WW-16 for areas outside of five (5') feet from pavement or outside of the zone of influence of traffic.

All embedment and backfill material and installation shall be per Standard Specification for "Embedment and Backfill."

- B. Where rock excavation is required, a minimum of six (6") inches of bedding is required for mains up to twenty-four (24") inch diameter and nine (9") inches for thirty (30") inch diameter and larger.

5.3.5.3.6 Thrust Restraint

A. Fittings

All plugs, caps, tees, reducers and bends, unless otherwise specified, shall be provided with thrust blocks or suitably restrained joints, as shown on plans.

B. Design

- The design pressure is the maximum pressure to which the pipeline will be subjected, with consideration given to the vulnerability of the pipe soil system

when the pressure is expected to be applied. In most cases, this will be the test pressure of the pipe, applied shortly after installation, when the pipe-soil system is normally most vulnerable.

- For buried pipelines, thrust restraint is achieved by transferring the thrust force to the soil structure outside the pipe. The objective of the design is to distribute the thrust forces to the soil structure in such a manner that joint separation will not occur in unrestrained joints.

C. Concrete Thrust Blocks

Vertical and horizontal thrust blocks shall be made of concrete having a compressive strength of not less than 3000 psi after 28 days. The blocks shall be placed between solid ground, and the fitting to be anchored. The mass of the block and/or the area of bearing on the pipe and on the ground in each instance shall be that shown on the plans. The blocking shall, unless otherwise shown or directed, be so located as to contain the resultant thrust force in such a way that the pipe and fitting joints will be accessible for repair. Concrete for thrust blocks shall be properly mixed by truck or portable mixer. At no time shall pipe be restrained with bags of premixed concrete unless properly mixed with a portable mixer.

D. Restraining Mechanisms

Restraining mechanisms for push-on or mechanical joints may be used instead of or in concert with concrete blocking. Tie rods, clamps, or other components of dissimilar metal shall be protected against corrosion by hand application of a suitable coating or by encasement of the entire assembly with 8-mil loose polyethylene film in accordance with ANSI/AWWA C105/A21.5.

- Glands shall be manufactured of ductile iron conforming to ASTM A536- 80, Grade 60-42-10. Set screws shall be hardened ductile iron. These devices shall have pressure rating with a safety factor of 281. Glands shall be listed with UL and Factory Manual.

5.3.5.3.7 Air Relief

- Air relief valves shall be installed at every intermediate apex point where air may accumulate in the force main.
- Each air relief valve that exhausts above ground must be equipped with an exhaust pipe extending to a downward facing elbow covered with a corrosion-resistant, twenty-four (24) mesh screened opening at an elevation of eighteen (18") inches above ground.
- Automatic air relief valves shall not be used in areas within the one hundred (100) year flood elevation or in areas where flooding may occur unless they are equipped with a downward facing exhaust pipe covered with a corrosion-resistant, twenty-four (24) mesh screened opening at an elevation of eighteen (18) inches above the ground surface and above the one hundred (100) year flood elevation.

- D. Manually operated air relief valves shall be used in areas within the one hundred (100) year flood plain and where flooding may occur.

5.3.5.3.8 Testing

- A. After the pipe has been laid and partially backfilled as specified under the Standard Specification for "Embedment and Backfill", all newly laid pressure pipe or any valved sections of it shall, unless otherwise expressly specified, be subjected to a hydrostatic pressure tests. The duration of each pressure test shall be for a period of not less than two hours and not more than six hours. The basic provisions of AWWA C 600 (DI pipe), C 605 (PVC pipe), shall be followed for all pressure testing.
- B. The test pressure shall not exceed pipe and/or thrust resistant design pressures. The test pressure shall not vary by more than plus or minus 5 psi for the duration of the test.
- C. All newly laid pipe or any valved section thereof shall be subjected to a hydrostatic pressure of at least 1.5 times the maximum working pressure at the lowest elevation in the line or 1.25 times the maximum working pressure at the highest elevation in the line. In no case shall the test pressure be less than 50 psi.
- D. Pressurization
- Each valved section of pipe shall be slowly filled with water and the specified test pressure, based on the elevation of the lowest point of the line or section under test and corrected to the elevation of the test gauge shall be applied by means of a pump connected to the pipe. The pump pipe connection and all necessary apparatus, including gauges and meters shall be furnished by the Contractor. Before applying the specified test pressure, air shall be expelled completely from the test section. If permanent air release valves are not located at all high points, the Contractor shall install corporation cocks at all points so that the air can be expelled as the section is filled with water. After all the air has been expelled, the corporation cocks shall be closed and the test pressure applied. At the conclusion of the pressure test the corporation cocks shall be removed and plugged.
 - Any exposed pipe, fittings, valves, and joints shall be examined carefully during the test. Any damaged or defective pipe, fittings, valves, or joints that are discovered following the pressure test shall be repaired or replaced with sound material and the test shall be repeated until it passes.
 - Pressure test shall be maintained for a minimum of 2 hours.
- E. Leakage Test
- After the completion of the pressure test, a leakage test shall be conducted to determine the quantity of water lost by leakage under the specified test pressure. Leakage shall be defined as the quantity of water that must be supplied into the newly laid pipe or any valved section thereof to maintain pressure within 5 psi of the specified test pressure after the pipe has been filled with water and the air has been expelled.

- Leakage shall not be measured by a drop in pressure in a test section over a period of time.

No ductile iron pressure pipe installation will be accepted if the leakage is greater than that determined by the following formula:

$$L = \frac{SDVP}{133,200}$$

Where:

L = allowable leakage, in gallons per hour

S = length of pipe tested, in feet

D = nominal diameter of the pipe, in inches

P = average test pressure during the leakage test, in pounds per square inch (gauge)

- No PVC pipe installation will be accepted if the leakage is greater than that determined by the following formula:

$$L = \frac{NDvP}{7,400}$$

Where:

L = allowable leakage, in gallons per hour

N = number of joints in length tested

D = nominal diameter of the pipe, in inches

P = average test pressure during the leakage test, in pounds per square inch (gauge)

5.3.6 Submersible Lift Station

5.3.6.1 General

5.3.6.1.1 Description

- This section covers the submersible lift station, including the wet well, pumps, valve pit, valves, by-pass pumping connection, drain lines, along with related items necessary to provide a complete and operable facility.
- The lift station shall be of the submersible type including:

- Installation of 2 submersible non-clog solids-handling pumps and motors, (an additional spare pump shall be provided by contractor,
- Installation of pre-cast concrete wet well with concrete ballast, complete with flat top, interior liner/coating/concrete additive, and hatches,
- Installation of pre-cast concrete valve pit, complete with flat top and hatches,
- Isolation plug valves and check valves for each pump and single air pressure gauge,
- Ductile iron discharge piping,
- Guide rails and pump removal components,
- Emergency pumping connection, including casting and isolation gate valve,
- Flexible expansion joint and miscellaneous ductile iron fittings,
- Sludge removal pipe, venting, floats,
- Drain lines from valve vault, includes cleanouts, pipe and check valve (duckbill type)
- Site improvements, including lighting with foundation and concrete pad at control panel,
- Pre-fabricated control building (if required) and controls,
- Telemetry.

5.3.6.1.2 Quality Control

- A. Referenced codes, specifications, and standards are a part of this specification to the extent applicable. Latest revisions shall apply. The following acronyms shall apply:

AFBMA – Anti-Friction Bearing Manufacturers Association

NEC – National Electric Code

FM – Factory Mutual

ANSI – American National Standards Institute.

ASTM – American Society for Testing & Materials.

HI – Hydraulic Institute.

NEMA – National Electric Manufacturer's Association
NFPA – National Fire Protection Association

UL – Underwriters Laboratories

5.3.6.1.3 Submittals

- A. Submit pumps, pre-cast concrete wet well and valve vault structures, interior coating for wet well, piping, fittings, rail package, hatches, castings, etc.

- B. Provide operation manuals for pumps and valves prior to 50% completion.
- C. Provide spare parts included in approved spare parts list prior to substantial completion.

5.3.6.1.4 System Start-Up and Testing

- A. Prior to substantial completion, Contractor shall test and demonstrate that all submersible equipment and systems in operation are working per original plan.

5.3.6.1.5 Operation and Maintenance Start-Up Support - Training

- A. Provide Start-Up Training for:
 - Pumps

5.3.6.1.6 Delivery and Storage

- A. Environmentally sensitive electrical equipment shall be protected against injury or corrosion due to environmental conditions or physical damage by storing under roof in a structure properly heated in cool weather and ventilated in hot weather. Control humidity in the storage at no more than 50 percent relative.
- B. Contractor shall not store submersible pump units in the wet well.
- C. All openings shall be capped with dustproof closures and all edges sealed or taped to provide a dust-tight closure.
- D. Pre-Cast Concrete Structures
 - Precast concrete units shall be protected from dirt and damage during transportation and handling.
 - Do not place units in positions which will cause overstress, warp or twist.
 - Store units off the ground.
 - Place stored units so that identification marks are discernable.

5.3.6.2 Products

5.3.6.2.1 Operating Conditions

- A. Climatic Conditions

All components exposed to weather must be constructed of material that is resistant to corrosion and will not require surface protection throughout its expected life. In general, these materials are stainless steel, aluminum, Krydon, fiberglass reinforced polyester (FRP), and ultraviolet stabilized PVC.

B. Hazardous Locations

Lift station equipment, pumps, electrical systems, and controls shall meet NEC Class 1, Division 1, Group C & D requirements. Rail packages shall be of the non-sparking configuration.

5.3.6.2.2 Pumps**A. Submersible Pump Systems**

- Submersible pump submittals shall be provided to the EWSU by the Contractor.

- B. Pumps shall be of the sealed submersible type, oil cooled, and capable of passing a 3-inch spherical solid.
- C. Pumps shall be dual vane enclosed impeller type pumps.
- D. The pump horsepower shall conform to the design specification information provided on the approved plans and shall have a maximum speed of 1750 RPM with a voltage of 240 or 440 V three (3) phase. The motor shall be compatible with variable speed controls.
- E. An identical, uninstalled, spare pump, with impeller, shall be furnished with the lift station. Contractor shall coordinate delivery location of the spare pump with the EWSU.
- F. Pumps shall have heat sensors embedded in the motor windings.
- G. Pumps shall be furnished with tandem tungsten carbide faced mechanical shaft seals in an oil-filled seal chamber. Seal chamber shall be fitted with a seal failure probe of the resistance probe type.
- H. The pump casting shall be fitted with a replaceable bronze wear ring.
- I. Acceptable manufacturers are KSB or Flygt.

5.3.6.2.3 Pump Removal System

- A. Provide all exposed nuts, bolts, and fasteners for installation. All hardware shall be 300 series stainless steel.
- B. Provide two rail pipes to be used to guide each pump from the surface to the discharge base connection. The guide rails shall be 2" schedule 40 stainless steel pipe. The weight of the pump shall bear solely on the discharge base and not on the guide rails. The guide rails shall be firmly attached to the access hatch frame.
- C. An adequate length of stainless steel lifting chain shall be supplied for removing pumps. The chain shall be connected to the pump or discharge flange as recommended by the pump manufacturer and also connected near the access hatch above the pumps in a manner to allow easy accessibility to the chain. The chain shall be of sufficient length to provide ease of pump removal and provide at least 5:1 safety factor.

- D. Guide rails for the inlet trash screening basket shall be a minimum of one (1") inch diameter stainless steel pipe.

5.3.6.2.4 Pre-Cast Concrete Wet Well

A. Material

- The wet well shall be fabricated pre-cast reinforced concrete base section, riser sections, and flat slab tops. All pre-fabricated concrete shall conform to the requirements of ASTM C478 and shall be watertight and not subject to decay or excessive corrosion. Precast sections shall contain waterproofing additive "XYPEX" or equivalent. In addition, an anti-corrosive additive, "CONSHIELD" or equivalent shall be included.
- The wet well floor shall have a fillet at the inner base wall of the wet well to prevent accumulation of solids at the base.
- Joints shall have tongue and groove and sealed with two (2) rings of preformed flexible butyl mastic.
- Handling or lifting lugs shall be provided for ease of unloading and placement. All lifting lugs shall be filled with a non-shrink grout upon installation.
- All through the wall pipe connections to the wet well shall be cast into the wet well.
- Pipe connections through all precast concrete walls for all but ductile iron pipe shall be flexible connectors meeting ASTM C923.
- Pipe connections through all precast concrete walls for ductile iron pipe shall be flexible connectors meeting ASTM C923 or modular seals designed for precast concrete structure pipe penetrations, similar to Link-Seal Model S-316.
- External joint collar shall be a wrapped joint with Rubber Backed Butyl Tape in minimum 6" width. Wrap shall conform to ASTM C877. All joints shall be primed with mastic primer prior to wrapping.
- Provide exterior coating for structures. Coating shall be coal tar epoxy coating with two components, 100% solids coating, especially formulated for high build applications meeting AWWA C210. Coating shall create a tough, flexible, chemical and impact resistant film with excellent resistance to aggressive water, acids, and caustics.
- If lining is specified, interior of wet well shall be lined with corrosion protection system such as:
 - Dura Plate 100 Liner System by A-LOK Products, Inc.
 - Multi-component stress skin panel liner system by SpectraShield, by CCI Spectrum Inc.
 - Approved equivalent.

- Product models indicated in the Drawings shall supersede the product models listed in this Specification in the event of a conflict.

5.3.6.2.5 Pre-Cast Concrete Valve Vault

A. Material

- The valve vault material specification shall be the same as for the wet well material.

5.3.6.2.6 Interior Coating for Wet Well (If Required)

A. Dura Plate 100 Liner System by A-LOK Products, Inc.

- Liner, channel joints, H-joints and corner joints shall be manufactured from an Acrylic PVC Alloy. All sheet compound will result in a semi-rigid material suitable for thermoforming to the contour of the structure and shall maintain a minimum wall thickness of 0.065 inches.
- Rubber Joint Composition – The fabricated liner panels shall be joined together by a slotted strip of EPDM rubber according to the manufacturer’s specification.
- Butyl Joint Composition – Sections of lined concrete structures shall be joined together by an approved butyl strip designed to produce sufficient squeeze-out between PVC returns.
- Physical Properties - All semi-rigid liner sheets, joint assembly components, corner and weld strips shall have the following properties when tested at 77 degrees +/- 5 degrees Fahrenheit.

- Chemical Resistant:

Chemical	Solution
Sulfuric Acid (H2SO4)	20%
Sodium Hydroxide (NaOH)	5%
Ammonium Hydroxide (NH3OH)	5%
Nitric Acid (HNO3)	1%
Ferric Chloride (FeC13)	1%
Soap	0.10%
Detergent	0.10%

- Physical Properties of Liner Panel:

	Test Method ASTM	Minimum Value
Tensile	D-638	6,100 psi
Elongation	D-638	28.5%
Tensile Modulus	D-638	325,000 psi
Flexural Strength	D-790	9,200 psi
Flexural Modulus	D-790	340,000 psi

Tensile Impact

D-1822

640 in-lb

- Antifungal and Antibacterial Properties - Dura Plate 100 Liner shall be made from Acrylic PVC Alloy sheets that resist bacteriological and fungal development. Sheet shall not readily provide a source of nutrients for bacteria and fungi. Plasticizers that allow a source of nutrients which support microbial growth for bacterial or fungal growth shall not be permitted. Sheet shall be subjected to fungus resistance testing in accordance with ASTM G-21 and bacteria resistance testing in accordance with ASTM G-22, Procedure B.
 - Liner panels shall have a minimum thickness of 0.065 inches. A combination of standing ribs and mechanical dovetails shall be used to secure the liner panels to the wall of the structure and shall be spaced a maximum of 6.0 inches apart.
 - Liner panel with a combination of standing ribs and dovetails in diameters 72" diameter and above shall be at least 0.75 inches high.
 - Liner with locking extensions shall be able to withstand a test pull of 100 pounds per linear inch applied perpendicular to the concrete surface for a period of 60 seconds. No rupture of the locking extensions or withdrawal from embedment shall be acceptable. This test shall be made at a temperature between 70 and 80 degrees Fahrenheit inclusive.
 - Liner panels shall be formed to correct radius to assure a true diameter match between joined precast sections when assembled.
 - Liner panels shall be formed with a continuous return into the joint for a minimum of 0.50 of an inch which shall afford protection between the lined precast sections.
 - All radius panels shall be vacuum tested for pinholes during the molding process and shall withstand a minimum of 25 inches of mercury for a period of 60 seconds. Any sections failing to meet this requirement shall be rejected.
 - Panel sections shall be custom formed to a specified height not to exceed 6' in overall length. Lengths specified shall include a tolerance ratio of +/- 0.0625 per foot.
 - Liner system shall include Duraplate slab top liner.
 - In plant inspections of panels cast into concrete sections shall be visually inspected for cuts or tears and shall be repaired following manufacturer's recommendations.
 - A-LOK liner shall have product warranty for a minimum of 10 years.
 - Installer shall have certified experienced personnel installing the product. Manufacturer's representative shall be required to inspect and perform testing requirements.
- B. Multi component stress skin panel liner system by SpectraShield, by CCI Spectrum Inc.
- The product shall have a 10-year limited warranty against failure of the coating.

- The materials to be utilized in the lining of the wet well structure shall be a product that is specifically manufactured to withstand the severe effects of hydrogen sulfide in a wastewater environment.
- Equipment for installation of lining materials shall be as recommended by the manufacturer
- The lining system shall be a multi-component stress skin panel liner system per the following:

<u>Installation</u>	<u>Liner</u>
Moisture Displacement Barrier	Primer
Moisture Barrier	Modified Polymer
Surfacer	Polyurethane/Polymeric blend foam
Final Corrosion Barrier	Modified Polymer

- Primer shall be 100% solids
- Modified polymer shall be sprayable, solvent free, two-component polymeric, moisture/chemical barrier specifically developed for a wastewater environment.

5.3.6.2.7 Hatches

- A. The Contractor shall furnish and install access hatches for both the wet well and valve pit. All required hatches shall be minimum 1/4" thick diamond plated aluminum, rated for 300 lbs. per square foot live load. The doors shall be equipped with a flush lifting handle that does not protrude above the cover, 316 stainless steel hold open arms, 316 stainless steel hinges and 316 stainless steel tamper resistant bolts/locknuts. The door shall be provided with a removable lift assistance mechanism. Doors shall be equipped with a watertight 316 stainless steel slamlock latch with removable outside key, fixed inside handle and 316 stainless steel striker plate bolted to the frame. Provide recessed staple for padlock.
- Hatches shall be installed flush with top of precast concrete structure.
 - Wet well hatch shall be two (2) door and sized per manufacturer's recommendation; however, there must be at least 4" clearance when the pump is installed or removed through the hatch opening.
 - Wet well hatch shall be equipped with an internal corrosion resistant safety grate fall through protection device that complies with OSHA Standard 1910.23. Safety grate shall be provided stainless steel hinges and mounting hardware.
 - The valve vault access shall be circular with a minimum opening of 30" diameter. The frame and cover shall be non-rocking, machine surface type, heavy duty, watertight assembly, and the cover shall have two concealed pick-holes and be stamped with the words "SANITARY SEWER". The casting shall be installed inverted to be flat along the top of the structure. The frame and cover shall be EJ model 1480 heavy duty or approved equal.

- The wet well hatch shall be stamped with letters with the words “SANITARY SEWER”.
- All parts of the frame in contact with concrete shall have a coating of bituminous paint.
- Manufacturer shall guarantee the hatches against defects in materials and workmanship for a period of ten (10) years.
- Acceptable manufacturers include East Jordan, U.S.F. Fabrication, Inc. or Owner approved equivalent.

5.3.6.2.8 Ductile Iron Piping and Fittings

A. Mechanical joint pipe

- Mechanical joint pipe shall be installed in buried applications. All mechanical joint piping shall be restrained with EBAA Iron Sale, Inc. Megalug or approved equivalent.
- Ductile Iron Pipe shall meet all standards of AWWA C151, with bolt holes in bell. Ductile Iron Pipe shall be Thickness Class 52, with gasket joints. Rubber-gasket joints shall be per AWWA C111. Pipe and fittings shall have exterior coated with an asphaltic coating approximately 1 mil thick. Provide interior lining material of quality of Protecto 401™ Ceramic Epoxy.
- Standard Fittings shall meet all standards of AWWA C110, ductile iron with bolt holes in bell.
- Compact Fittings shall meet all standards of AWWA C153, with bolt holes in bells.

B. Flanged Pipe

- Flanged pipe shall be installed in all exposed applications.
- Ductile Iron Pipe shall meet all standards of AWWA C151 with bolt hole aligned per AWWA C115 conforming to the drilling and facing of ANSI B16.1 Class 125 flanges. Ductile Iron Pipe shall be provided with minimum 1/8” thick gaskets with three (3) bulb type rings. Flat rubber gaskets are not considered equal in performance. Rubber-gasket joints shall be per AWWA C111. Pipe and fittings shall have exterior coated with an asphaltic coating approximately 1 mil thick. Provide interior lining material of quality of Protecto 401™ Ceramic Epoxy.
- Standard Fittings shall meet all standards of AWWA C110, ductile iron with bolt holes in bell.
- Compact Fittings shall meet all standards of AWWA C153, with bolt holes in bells.

C. Expansion Coupling

- Install flexible expansion joint were shown on the plans. Flexible expansion joint shall be manufactured of ductile iron conforming to the material requirements of ASTM A536 and AWWA C153.

- Flexible expansion joint shall be pressure tested prior to shipment against its own restraint to a minimum of 350 psi. A minimum 2:1 safety factor, determined from the published pressure rating, shall apply.
- Each flexible expansion joint shall consist of an expansion joint designed and cast as an integral part of a ball and socket type flexible joint, having a minimum per ball deflection of: 20° and 4-inches minimum expansion. Additional expansion sleeves shall be available and easily added or removed at the factory or in the field. Both standardized mechanical joint end connections shall be available.
- Provide mechanical joint restraint on each end.
- All internal surface (wetted parts) shall be lined with a minimum of 15 mils of fusion boded epoxy conforming to the applicable requirements of AWWA C213. Sealing gaskets shall be constructed of EPDM. The coating and gaskets shall meet ANSI/NSF-61.
- Exterior surfaces shall be coated with a minimum of 6 mils of fusion bonded epoxy conforming to the applicable requirements of AWWA C 116.
- Appropriately sized polyethylene sleeves, meeting AWWA C105 shall be included for direct bury application.
- Flexible expansion joints shall be Flex-Tend as manufactured by EBAA Iron, Inc., or approved equal.

D. Quick Connect Coupling

- Quick connect couplings shall be male stainless steel cam and groove-type connectors matching EWSU standby pump connection fittings. Provide stainless steel female dust cap for connectors.
- Coupling shall be as manufactured from PT Coupling or approved equivalent.

5.3.6.2.9 Valves

A. Check Valve

- Check valve shall be Swing-Flex Check Valve as manufactured from Val-Matic Valve & Manufacturing Corp or approved equivalent.
- Swing-Flex non-slam, non-clogging, check type with resilient seat shall be per AWWA C508. Include interior coating according to AWWA C550 and ends to match piping. The check valve shall be of the full body flow type, with a domed access cover and only two moving parts, the flexible disc and the Disc Accelerator. The disc accelerator shall be of one piece construction and provide rapid closure of the valve in high head applications. The disc accelerator shall be enclosed within the valve and shall be field adjustable and replaceable without removal of the valve from the line. The disc accelerator shall be securely held in place captured between the cover

and disc. It shall be formed with a large radius to allow smooth movement over the disc surface.

- Valve body and cover shall be Ductile Iron, ASTM A536 Grade 65-45-12.
- Disc: Buna-N (NBR), ASTM D2000-BG; precision molded, steel and nylon reinforced.
- Disk Accelerator shall be Type 302 stainless steel.
- Valve shall be provided with interior and exterior fusion bonded epoxy coating.
- Swing Check Valve shall have minimum 250 psig rating.
- Swing Check Valve shall be provided with backflow actuator.
- Flanges shall be drilled per ANSI B16.1, Class 125.

B. Plug Valve

- Plug Valve shall be as manufactured by Val-Matic Valve & Manufacturing Corp, or Milliken Valve Company or approved equivalent.
- Plug Valve shall be cast iron eccentric plug valve suitable for wastewater applications and comply with ANSI/AWWA C517. The interior and exterior of the valve shall be coated with an NSF/ANSI 61 approved fusion bonded epoxy.
- Valve body and cover shall comply with ASTM A 536 Grade 65-45-12 for working pressures up to 250 psig.
- Plug valves shall be quarter-turn, non-lubricated with resilient encapsulated plug.
- Plug shall consist of a one-piece cast iron (ASTM A126) or ASTM A536 Grade 65-45-12 ductile iron and fully encapsulated with resilient facing per ASTM D2000-BG and ANSI/AWWA C517 requirements.
- Radial shaft bearing shall be constructed of self-lubricating Type 316 stainless steel. The top thrust bearing shall be Teflon. Cover bolts shall be corrosion resistant with zinc plating.
- Gear actuators shall be designed to withstand, without damage, an input torque of 300 ft-lbs. for nuts. Valve shall be equipped with a 2-inch square nut for direct quarter turn operation.
- Valve shall include a totally enclosed and sealed worm gear actuator with position indicator and externally adjustable open and closed stops.
- Plug Valve shall be provided flanges drilled per ANSI B16.1, Class 125 for installation in valve vault.

C. Gate Valve

- Resilient Wedge Gate Valve shall be as manufactured by Mueller Co.; Water Products Division or approved equivalent.

- Resilient Wedge Gate valve shall comply with AWWA C509 and be provided with a non-rising stem. Valve shall be rated for minimum 250 psig working pressure rating.
- Resilient Wedge Gate Valve shall have restrained mechanical joints for buried applications.
- Wedge shall be totally encapsulated rubber wedge. O-ring seals shall be provided at all pressure retaining joints. Interior coating shall comply with AWWA C550. Exterior coating shall be NSF61 certified fusion-bonded epoxy.
- Gate valve in buried service shall be provided with a cast iron valve box with heavy duty cover rated for traffic loads. Provide “SEWER” lettering on lid. Provide minimum 18” x 18” concrete collar (4000 psi) with minimum thickness of 12” around each valve casting. Contractor shall provide Owner with steel tee-handle and socket matching valve operating nut for deepest buried valve.

5.3.6.2.10 Vents

- A. Vents, minimum 4” diameter, shall be made of 304 series stainless steel.
- B. Provide stainless steel insect screen and ½” x ½” protective welded wire screen covering.

5.3.6.2.11 Strain Relief Grips

- A. All pump power and sensor cables shall be fitted with stainless steel Kellem type strain relief grips.
- B. Cable restraints shall support the cables from the top of the wet well.
- C. Strain relief grips shall be attached by stainless steel hooks with snap clips.

5.3.6.2.12 Pressure Gauges

- A. Pressure gauges shall be glycerin-filled diaphragm sealed units.
- B. Case, diaphragm, isolation valve, and connecting tubing shall be 316 SS.
- C. Isolation valve shall be provided at the connection of the process fluid tubing with the main piping.
- D. Pressure gauge shall be firmly supported by rigid tubing or by a SS support bracket where flexible tubing is used.
- E. Pressure range shall be 0 - 100 psi.
- F. Install at location shown on the plans.

5.3.6.2.13 Specialty Tools

- A. Furnish with each different type, kind, or size of pumping unit, two (2) sets of any special tools, gauges, and fixtures required to adjust, operate, maintain, or repair the pump.

- B. Tools shall be suitably marked high-grade items.
- C. Furnish tools in neat, special steel cases fitted with locks and keys and delivered to the EWSU prior to the initial operation of equipment.

5.3.6.2.14 Drain Piping and Clean-outs

- A. Drain piping and fittings shall be gasket pipe, manufactured from Type 1, Grade 1 Polyvinyl Chloride (PVC) material with a Cell Classification of 12454 per ASTM D1784. The pipe shall be Schedule 40, manufactured in strict compliance with ASTM D1785. All pipe shall consistently meet the applicable quality assurance test requirements of these standards with regard to material, workmanship, burst pressure, flattening and extrusion quality. All gasket seals shall meet the requirements and/or exceed the requirements of ASTM F477 for elastomeric seals.
- B. Cleanout casting shall be Heavy Duty, gray iron, EJ 1574 or approved equivalent. Casting shall have "Sewer Drain" noted on the casting. Casting shall be provided with minimum 20" x 20" concrete collar (4000 psi) and 12" thickness.
- C. Duck Bill Check Valves shall be as manufactured by Tideflex Technologies, Series TF-1 or approved equivalent. Body of check valve shall be made from pure gum rubber elastomer product. Contractor shall provide 316 stainless steel compression clamp.

5.3.6.2.15 Concrete Pad and Control Panel

- A. Contractor shall provide a 4" thick concrete pad in front of the control panel. Concrete pad shall be at minimum, equal width of the control panel
- B. Concrete shall be minimum 4000 psi compressive strength. Provide a minimum of 6" compacted aggregate base No. 8 or No. 5, per INDOT Standard Specifications, under the pad.

5.3.6.2.16 Lighting

Lighting shall be provided as specified on the approved drawings. Area lighting may be provided either as a pole mounted system or direct connection to the control building.

Lighting shall be directed so that it illuminates the area of the wet well and as much of the access area as feasible.

- A. Pole Mounted
 - Contractor shall provide a 25 foot tall, seamless, one-piece extruded tube of aluminum alloy 6063-T6. After tapering, shaft is welded to a cast aluminum anchor base of alloy A536, heat-treated to T-6 temper and rotary sand finished. Pole shall have minimum thickness of 0.188 inches.
 - Contractor shall provide cast aluminum anchor bolt covers.
 - Contractor shall provide an aluminum pole cap for side arm mounted luminaires.
 - Pole shall have a gasketed handhold cover. Cover shall mount flush.

- Pole shall include a mechanically fastened internal pendulum vibration dampener.
- Contractor to provide stainless steel anchor bolts (min ¾") and hardware, including nuts and flat washers. Actual size and length shall be per Manufacturer's recommendation.
- Pole and fixture shall be designed to withstand steady wind loads in excess of 90 mph per AASHTO Wind Map for Lighting Equipment. Contractor shall verify the Effective Projected Area (EPA) for the entire light pole assembly to ensure maximum allowable pole EPA values do not exceed manufacturer's rating.
- Pole shall be provided a standard thermoset polyester powder coat paint over titanated zirconium conversion coating.
- Refer to electrical specifications for materials and installation for wiring, conduit, luminaire, etc.

B. Mounted on Control Building

- Area lighting may be attached directly to the control building at its highest point. Lighting shall be installed on the side of the building that faces the wet well and access area.

5.3.6.2.17 Mechanical Building

A. A control building will be required if any of the following conditions are met:

- Flow rate exceeds 250 GPM
- Variable frequency drives are used for reasons other than phase conversion
- Pump horsepower is greater than 10 Hp
- If backup generator with day tank is required

If none of the preceding conditions are met, a control building will not be required. The control panel can be placed on a concrete pad.

- B. If required, a control building shall be provided for the purpose of housing the control and electrical equipment and as a mechanical storage facility. The minimum size shall be 8' X 8'. The standard manufactured size is 10' X 12'.
- C. The building shall be securely anchored to a concrete slab of six (6") inches in thickness. The building shall be placed in an area that is not subject to flooding.
- D. A precast concrete modular building shall be EASI-SET brand as manufactured by Easi-Set industries (ESI), Midland, Virginia or a licensed manufacturer of Easi-Set Buildings.
- E. The building shall be provided by the manufacturer with all necessary openings as specified in the approved drawings.

- F. The building roof shall be either sloped or gabled options. The sloped roof shall extend a minimum of 2 ½" beyond the wall panel on each side of the building. The gable roof option shall extend a minimum of six (6") inches beyond the wall panel on each side of the building.
- G. The Roof, floor, and wall panels must each be produced as a single component monolithic panel. No roof, floor, or vertical wall joints will be allowed, except at corners. Wall panels shall be set on top of the floor panel.

5.3.6.3 Execution

5.3.6.3.1 Excavation for Structures

- A. Contractor shall relocate or temporarily remove or support existing utilities within the project limits prior to excavating.
- B. Contractor shall contain excavation within project limits, specified easements, rights-of-way or Owner's property.
- C. Surface and groundwater controls shall be accomplished in coordination with the required excavation. Contractor shall provide dewatering controls to limit and reduce groundwater infiltration into the excavation. Groundwater shall be a minimum of two feet below the bottom of the subgrade.
- D. Contractor shall be responsible for ensuring existing structures, including residential homes, will not be subject to settlement due to dewatering activities with induced construction vibrations.
- E. Contractor shall excavate to subgrade elevations as shown on the plans. Excavation includes excavating pavements and obstructions visible on surface, underground structures, utilities and other items indicated to be removed; together with soil, boulders and other materials.

5.3.6.3.2 Backfill

- A. All backfill of structures shall be performed according to the Specification Section for "Backfill and Embedments".

5.3.6.3.3 Precast Structure Installation

- A. General: Install manholes complete with appurtenances and accessories indicated.
- B. Install watertight joint sealant and exterior joint collar on all wet well and valve vault joints.
- C. Place castings and access hatch frames into precast concrete flat tops flush with finished surface.
- D. Where indicated on the plans, install poured in place concrete ballast. Contractor may elect to submit precast ballast. Reinforcement shall be installed or doweled per plan requirements.

5.3.6.3.4 Piping Installation

- A. General locations and arrangements: Drawing plans and details indicate general location and arrangement of underground sewer or drain piping. Location and arrangement of piping layout take into account design considerations. Install piping as indicated, to extent practical. Where specific installation is not indicated, follow piping manufacturer's written instructions.
- B. Install gravity flow, non-pressure drainage piping to a minimum slope of ¼" per foot. Provide bedding and backfill per plan details and per Backfill requirements.
- C. Install force main, pressure piping, with 48-inch minimum cover. Install ductile iron piping and special fittings according to AWWA C600. Provide bedding and backfill per plan details and per Backfill requirements.
- D. Ductile Iron pipe with flanged connections shall be provided in the wet well and valve vault, in exposed locations only. Ductile iron pipe with mechanical joint piping shall be installed in direct burial applications.
- E. Pipe couplings and fittings shall at minimum match pipe rating unless otherwise indicated.
- F. Force main piping, valves and appurtenance shall be subject to Hydrostatic Testing requirements.

5.4 Technical Specifications - Water

5.4.1 Construction Specifications

5.4.1.1 General

5.4.1.1.1 Description

- A. Scope: The Developer's Contractor shall furnish and install pipe, fittings, valves, hydrants, air valves, meter pits, and appurtenances necessary to complete work shown or specified on the Utility approved drawings.
- B. Codes, specifications and standards referred to by title or number in this specification shall be adhered to, and latest revisions shall apply in all cases.
- C. Abbreviations:
 - ANSI – American National Standards Institute
 - ASTM – American Society for Testing & Materials
 - AWWA – American Water Works Association
- D. All pipe fitting and valve sizes and references to pipe diameter on the drawings or in the specifications are intended to be nominal size or diameter and shall be interpreted as such.

5.4.1.1.2 Quality Assurance

- A. The Developer’s Contractor shall mark pipe, fittings, valves and hydrants according to the applicable specifications or standards.
- B. The Developer’s Contractor shall test and disinfect water mains constructed as shown on the Utility approved drawings, as specified in Section 3.1 and Section 3.8 of this document.
- C. Cost for all testing shall be paid for by the Developer or his/her Contractor. If samples do not pass the requirements of the bacteriological analysis, the water main will be disinfected and sampled again. This procedure will be followed until the samples pass the analysis.

5.4.1.1.3 Product Delivery, Storage, and Handling

- A. The Developer or his/her contractor shall have sole responsibility for the delivery, storage and handling of all products.
- B. No damaged products shall be used on projects that are to be accepted by the Utility.

5.4.1.2 Products

5.4.1.2.1 General

All pipe, fittings, valves, fire hydrants, and other appurtenances shall conform to the EWSU Water Department Material Specifications, as shown on the Utility approved drawings or as required by the manufacturer’s and ANSI / AWWA specifications. All pipe, fittings, valves, fire hydrants, and all other appurtenances shall be new and unused unless prior consent for reuse of products or materials has been granted in writing by the Utility.

5.4.1.2.2 Buried Water Main Pipe and Fittings

- A. Ductile Iron Water Mains
 - Ductile iron pipe shall meet the requirements of ANSI/AWWA C151/A21.51. Design and manufacture pipe for the pressure class listed plus 100 psi surge pressure. Additionally, a safety factor of 2.0 and a depth of cover, indicated on the drawings or as required by the manufacturer’s and ANSI/AWWA specifications, shall be included. Minimum thickness class shall be as follows:

TABLE 5-3: DUCTILE IRON PIPE PRESSURE CLASSES

SIZE RANGE	PRESSURE CLASS
4" thru 12"	C152
14" thru 24"	C151

- Pipe joints shall be restrained push-on type. Joints shall meet the requirements of ANSI/AWWA C111/A21.11.
- Push-on joints shall be compression type, Type POJ-1, single gasket type conforming to ANSI A21.11 "Rubber Gasket for Cast Iron Pressure Pipe and Fittings." The bell shall have cast or machined gasket socket recesses, a tapered annular opening and

flared socket design to provide deflections up to a maximum of 5 degrees. Plain spigot ends shall be suitably beveled to permit easy entry into bell centering in gasket and compression gasket. The joint shall be liquid tight under all pressure ranges from vacuum up to 350 psig. Sufficient lubricant shall be furnished to provide a thin coat on each spigot end; Lubricant shall be non-toxic, impart no taste or odor, and shall have no deleterious effect on the rubber gasket. The lubricant shall be of such consistency that it can be easily applied to the pipe in hot and cold weather, and shall adhere to a wet or dry pipe.

- Ductile iron pipe within casing pipe shall be US TR Flex joint pipe unless otherwise indicated.
- Polyethylene encasement for ductile iron water mains shall meet the requirements of ANSI/AWWA C105/A21.5. Install polyethylene encasement on all ductile iron water mains.

B. Polyvinyl Chloride (PVC) Pipe

- PVC pipe with a nominal diameter of 12 inches or less shall conform to AWWA C-900, DR-18. The material used also shall conform to ASTM 01784, Class 12454-B (PVC 1120).
- PVC pipe with a nominal diameter of 16 inches or larger shall conform to AWWA C-905, DR-18. The material used also shall conform to ASTM 01784, Class 12454-B (PVC 1120).
- PVC pipe within a casing pipe shall be Certa-Lok C900 or C905 with integral restrained joints as manufactured by Certainteed Corporation, Valley Forge, PA or Fusible C900 or C905 pipe as manufactured by Underground Solutions.

C. Fittings and Adapters

- Fittings shall be ductile iron. Fittings for standard size pipe shall meet the requirements of ANSI/AWWA C153/A21.53. Design and manufacture fittings for a pressure rating of at least 350 psi.
- Fitting joints shall be restrained mechanical joints or restrained push-on joints. Mechanical joint restraint devices shall be EBAA Iron, Inc. Mega-Lugs or approved equal. Joints shall meet the requirements of ANSI/AWWA C111/A21.11. Thrust block mechanical joints only where indicated on the Drawings or as directed by the Owner. Pipe connecting to restrained joint fittings shall be restrained as indicated on the drawings or as required by the manufacturer's and ANSI/AWWA specifications.
- Adapters from ductile iron water mains to flange joint valves or fittings shall be ductile iron. Adapters shall meet the requirements of ANSI/AWWA C110. Design and manufacture adapters for a pressure class rating of 350 psi.

- Adapter ends connecting to ductile iron water mains shall be one of the following: plain end, push-on joint, mechanical joint or restrained push-on joint. Adapters with plain ends, push-on joints or mechanical joints may be used where restrained joints are not required. Adapters shall have restrained push-on joints where restrained joint piping is required, as indicated on the Utility approved drawings. Mechanical joints and restrained push-on joints shall meet the requirements of ANSI/AWWA C111/A21.11. Restrained joints shall be Lok-Ring, Lok-Fast, Lok-Tyte or as approved by the Engineer.
- Adapter ends connecting to flange joint valves or fittings shall have joints complying with the specifications for the applicable valves or fittings.
- All pipe, fittings and adapters shall be lined with single layer cement mortar lining. Cement mortar lining and seal coating shall meet the requirements of ANSI/AWWA C104. Coat the outside surfaces of all pipe, fittings and adapters with a bituminous coating, complying with ANSI/AWWA C151.
- Gaskets for mechanical joints and push-on joints shall meet the requirements of ANSI/AWWA C111/A21.11.
- Nuts & Bolts:
 - Nuts and bolts for mechanical joints shall be high strength, heat treated, and alloy steel. Nuts shall be hexagon nuts, bolts shall be tee head bolts. Nuts and bolts shall meet the requirements of ANSI/AWWA C111/A21.11.
 - Nuts and bolts for restrained push-on joints shall meet the requirements of the joint manufacturer.

D. Polyethylene Pipe (2" Domestic Service Line Only)

- Pipe and fittings shall be AWWA C901 made of a high density polyethylene pipe resin, PE3408, possessing a minimum cell classification of 345434C as defined in the latest revision of ASTM D2734 for high density polyethylene pipe and manufactured to the standards of NSF 14 and 16.
- All pipe and fittings to be incorporated into the work shall be made from virgin polyethylene pipe compound material. The pipe shall possess a minimum dimension ratio (DR) of 9 with a copper tube size (CTS) outside diameter. The pipe and fittings shall be manufactured for a pressure rating of 200 psi.
- The polyethylene resin compound shall contain antioxidants and be stabilized with carbon black against ultra-violet degradation to provide protection during processing and subsequent weather exposure. Pipe shall have permanently extruded blue stripe on 4 sides.
- Pipe made from polyethylene resins shall be homogeneous throughout and be free of visible cracks, holes, foreign material, blisters or other deleterious faults.

- Joining Systems:
 - Pipes shall be jointed to one another and to polyethylene fittings by thermal butt-fusion or by socket fusion in accordance with ASTM D-2161.
 - Joining of the pipes and fittings shall be performed in accordance with the procedures recommended by the pipe manufacturer. Depending upon the installation requirements and site location, joining shall be performed within or outside the excavation. Joints between pipe sections shall be smooth on the inside and internal projection beads shall not be greater than 3/16 inch.
 - The tensile strength at yield of the butt-fusion joints shall not be less than the pipe. A specimen of pipe cut across the butt-fusion joints shall be tested in accordance with ASTM D-638.
- Environmental Stress Cracking Resistance: When the environmental stress cracking resistance (ESCR) of the material is measured in accordance with ASTM D- 1693, Condition B, the material shall withstand not less than 100 hours in 25 percent solution Igepal CO-630 or 1,000 hours in 100% Igepal CO-630 before reaching a 50 percent failure point (FSO).
- Tests:
 - General - Tests for compliance with this Specification shall be made as specified herein and according to the applicable ASTM specifications. A certificate of compliance with these specifications, along with a report of each test, shall be furnished by the manufacturer for all material furnished under this specification. In addition, the purchaser may, at his own expense, witness inspection and test of the materials.
 - Tensile Properties - The tensile strength, yield strength, elongation and elastic modulus of the material shall be determined in accordance with ASTM D-638. ASTM D- 638 shall be used to determine that the thermal butt-fusion joints are stronger than the materials joined.
 - Melt Index - The melt index of the polyethylene resin shall be determined in accordance with ASTM D-1238 and shall be equal, or between 0.1 g/10 min. and 1.0g/10 min.
 - Density - The density of the base polyethylene resin shall be determined in accordance with ASTM D-1505 and be equal or between 0.941 g/cc and 0.055 g/cc.
 - Environmental Stress Cracking Resistance - The material shall be tested in accordance with ASTM D-1693, Condition B. The test reagent shall be Igepal CO-630 in 25 percent solution by volume. The specimens shall be in the solution not less than 100 hours before reaching a 50 percent failure point (F50).

- Rejection - Polyethylene pipe and fittings may be rejected for failure to meet any of the requirements of this specification.
- E. Pipe and Fittings Smaller than 4-Inches
- Pipe smaller than 4 inches that shall maintain pressure, to be used for blow-offs, air reliefs, etc., shall be brass. Piping on the non-pressure side of blow off valves may be galvanized. All 2" sleeves on blow off assemblies shall be brass.
 - Fitting and couplings that are brass shall meet the requirements of ASTM B16.18. Construct and manufacture fittings and couplings for a pressure rating of 150 psi.
 - Unions shall be cast bronze and shall meet the requirements of ASTM B16.19. Design and manufacture unions for a pressure rating of 150 psi.
 - Flanges for connection of screwed joint pipe to flange joint valves or fittings shall be 125-16 cast iron, screwed companion flanges complying with both ASTM A126 and ANSI B16.1.
 - Tape for screwed joints shall be Teflon®.
 - Gaskets for flange joints shall be 1/16-inch thick, full face and conform to ANSI/AWWA C111/A21.11. Gaskets shall be rubber or as approved by the Engineer.
 - Bolts for flange joints shall be steel, heavy hexagon head machine bolts. Nuts shall be steel, semi-finished, heavy hexagon nuts. Nuts and bolts shall meet the requirements of ASTM A307 for Grade B and be zinc-coated alloy steel.

5.4.1.2.3 Casing Pipe for Water Mains

- A. Casing pipe shall be bituminous coated steel pipe with a minimum wall thickness of 0.375 inches and shall be capable of withstanding traffic or loads of pavement, subgrade and traffic, where applicable. The casing pipe and joints shall be constructed to prevent leakage of any matter from the casing or conduit throughout its entire length.
- B. Casing pipe used for railroad crossing shall meet the minimum standards set forth by the railroad involved.
- C. Mechanical seals shall be used to seal the annular space between the casing and carrier pipe. Seal elements shall be made of EPDM and pressure plates shall be made of reinforced nylon polymer. All hardware shall be made of 316 stainless steel. Mechanical seals shall be Link-Seal or approved equal.
- D. All carrier pipe within a casing shall utilize casing spacers to maintain separation between the carrier pipe and the casing. Spacers shall be installed on the carrier pipe no more than every 10 feet. Larger pipe may require a more frequent spacing to support the load, this shall be determined by the manufacturer's recommendation for the spacer used. Casing spacers used on carrier pipes larger than 8 inches shall be made of stainless steel with polyethylene/Teflon runners, model CCS as manufactured by Cascade Waterworks Mfg. Co. or approved equal. Casing spacers used on carrier pipes 8

inches and smaller may utilize Model CCS spacers as manufactured by Cascade Waterworks Mfg. Co. or Phoenix Series Casing Spacers as manufactured by Cascade Waterworks Mfg. Co. or approved equal.

5.4.1.2.4 Valves

A. Resilient Seat Gate Valves

- Resilient seat gate valves shall be used on all 12 inch and smaller pipes.
- Resilient seated buried gate valves 4 inches and larger shall be constructed with an iron body and a non-rising stem. Valves shall be minimum Class 150 working pressure and meet the requirements of ANSI/AWWA C515 or C509 and have mechanical joint ends. Mechanical joints and joint accessories shall comply with ANSI/AWWA C111/A21.11. Valve opening direction shall be to the right.
- Gate valves 4 inches and larger installed above ground or in structures shall be ductile iron body. Valves shall meet the requirements of ANSI/AWWA C515. Outside screw and yoke gate valves shall have flange joint ends and malleable iron handwheels. Valve opening direction shall be to the right.

B. Tapping Valves

- Tapping valves shall comply with both ANSI/AWWA C515 and C509 and have one flange mechanical joint. Resilient seat wedges, gate rings and body-seat rings shall be oversized to permit entry and exit of tapping machine cutters. Valve opening direction shall be open right.
- Valve end connecting to tapping sleeve shall have a flange for bolting to the sleeve. The flange shall have a tongue which fits a recess in the sleeve. Tongues shall meet the requirements of MSS SP-60. Resilient seated gate valves having a port diameter equal to or exceeding 1/4 inch over nominal diameter shall not require a tongue. Flange dimensions and drilling shall meet the requirements of ANSI B 16.1. Nuts, bolts, and gaskets for flange joints shall meet the requirements of ANSI/AWWA C110. Nuts and bolts shall be stainless steel, and gaskets shall be rubber, or as approved by the Engineer. Mechanical joints and accessories shall meet the requirements of ANSI / AWWA C111/A21.11. A full nominal diameter cutter shall be used for tapping.
- Tapping valves 16-inch and smaller shall be installed vertically, if depth allows. Tapping valves 20-inch and larger shall be installed horizontally. Valves 16-inch and larger shall have gear operators with enclosed gear cases suitable for buried service. Gear cases shall be extended type or totally enclosed type. Extended type gear cases shall have bolted side plates to cover stem and stuffing box.

C. Butterfly Valves

- Butterfly valves shall be used for 16 inch and larger pipe.

- Rubber seated butterfly valves and operators shall be minimum Class 150B and meet the requirements of ANSI / AWWA C504.
- Butterfly valves shall be designed for a working pressure of 250 psi.
- Each buried butterfly valve shall have a manual operator with 2-inch operating nut and valve box. Valve opening shall be to the right.
- Shaft shall be of the through type and shall be marked on the end to indicate the position of the valve disc with respect to the shaft.
- Discs shall be of corrosion-resistant alloy cast iron.
- Valves shall be equipped with a stainless steel stop in the body to prevent the disc from rotating through the closed position. The shaft shall be of the “Split-V” or chevron type. The operator shall be permanently lubricated and sealed for buried service.
- The bolts, screws and nuts used in the assembly of the valve and exposed to soil shall be corrosion resistant, stainless steel.
- Butterfly valves used in connection with ductile iron pipe shall be equipped with standard mechanical joint ends.

D. Combination Air and Vacuum Valves

- Combination air and vacuum relief valves shall comply with ANSI / AWWA C512-04. Valves shall be single body style, double-orifice type, combination air and vacuum relief valves with freeze-proof capability for line service below 150 psig. The valves shall be designed for the service intended, and shall be corrosion-resistant and suitable for contact with potable water per NSF 61 standards. The combination air valves shall be as manufactured by Val-Matic Corporation, or approved equal, as listed below:

TABLE 5-4: COMBINATION AIR AND VACUUM RELIEF VALVES

SIZE	VAL-MATIC MODEL NUMBER
1"	201C.2
2"	202C.2
3"	203C.2
4"	204C.2
6"	256CS

Combination air and vacuum relief valves shall be installed within a vault and outside of the roadway.

- E. City of Evansville Waterworks Department Requirements: All valves provided shall also meet the following requirements which shall govern if there is a conflict between the Waterworks Department requirements and other specifications in this Section.

- All valves and parts shall be manufactured and assembled in the continental United States.
 - Valves shall be constructed to open right (clockwise) and shall have a two- (2) inch square operating nut. Operating nut shall be painted red and be visible from valve box cover.
 - Design and machining of valves shall permit servicing packing while valves are in service without undue leakage ("O" ring stuffing box will be acceptable).
 - The thrust ring on the stern shall be properly and adequately bushed.
 - The thrust ring must be an integral part of the sterns.
 - All valves shall have full pipe size opening through the seat ring. All bonnet and packing gland bolts shall be stainless steel.
 - All valves shall be furnished with mechanical joint accessories including bolts, glands and gaskets. Bolts and nuts shall be made of cast iron (Corten or approved equal). Anti-rotation bolts shall be furnished for all slotted holes in valves.
 - All test plugs must be solid brass or stainless steel.
 - All valves shall utilize a box-lok valve box alignment device properly sized for the valve used.
- F. Buried valves 2 inches and smaller shall be curb stops. Curb stops shall meet the applicable requirements of ANSI / AWWA C800, ASTM B-62 for 85-5-5-5 composition bronze and USAS B2.1. Curb stops shall be Mueller, Ford or approved equal.

5.4.1.2.5 Valve Boxes

- A. Valve boxes for butterfly valves and gate valves shall be cast iron. Valve boxes shall be two piece or three piece type. Each two piece box shall be complete with bottom section, top section and cover. Each three piece box shall be complete with base, center section, top section and cover. Valve boxes shall be extension type with slide or screw type adjustment. Each base and bottom section shall be the proper size for the valve served. Each valve box assembly shall be the proper length for the valve served. The minimum thickness of metal shall be 3/16-inch. Cast the word "WATER" in each valve box cover. Valve boxes shall be Tyler Type 562-S or 546-S, or approved equal. All valve boxes shall be installed with a valve box alignment device properly sized to fit the corresponding valve.
- B. Water service valve boxes for curb stops shall be cast iron. Curb boxes shall be extension type. Each curb box shall be complete with foot piece, curb box and lid. Curb boxes shall be Tyler Type 930, or approved equal. All curb boxes shall be installed with a curb box centering device properly sized to fit the corresponding valve.

5.4.1.2.6 Fire Hydrants

- A. Fire hydrants shall be dry-barrel post type with flanged breakaway sections, compression shut-off, traffic model and shall comply with ANSI / AWWA C502. The main valve size shall be 5-1/4". Inlets shall be 6-inch mechanical joint. Each hydrant shall have one (1) 5" Storz connection and two (2) 2-1/2" hose connection nozzles. Nozzle threads and hydrant opening direction shall be consistent with existing fire hydrants in the waterworks in which the fire hydrants are installed, unless otherwise directed by the Engineer or Utility. Each hydrant shall be of the proper length for the water main to which it will be connected. Fire hydrant prime and finish coating shall meet the requirements of ANSI / AWWA C502. Paint color shall meet the City of Evansville requirements listed herein.
- B. City of Evansville Waterworks Department Requirements
- Hydrants shall be for 250 psi working pressure and a test pressure of a minimum of 300 pounds hydrostatic pressure.
 - The main valve rubber shall be neoprene.
 - Hydrant outlet nozzles:
 - Two (2) 2-1/2" hose nozzles N.S.T. 3-1/16 O.D. by 7-1/2" T.P.I. The caps shall have a 1-1/2" pentagonal operating nut.
 - One (1) 5-inch steamer nozzle. 6-5/32 inches O.D. by 4 T.P.I. The cap shall have two lugs one inch in width, one inch in height spaced 180 degrees apart along the perimeter. The length of the lug along the perimeter of the cap shall be 2-3/4 inches and taper outward to 3-1/4 inches.
 - The size of the valve opening or intake mechanism in the bottom of the hydrant shall be 5-1/4 inches in diameter.
 - The inlet connection shall be for a 6 inch cast iron pipe with mechanical joint.
 - Inside diameter of the standpipe not less than 7 inches in diameter.
 - Drain Valve:
 - The hydrant shall have a positive non-corrodible type drain valve. When the hydrant is opened, the drip valve will close the drain, and when the hydrant is closed, the drain will open.
 - All drain valve openings shall be bronzed lined.
 - Operating stem and related parts:
 - The operating stem shall be made in two (2) sections jointed together with a brass or stainless steel breakaway type coupling and two stainless steel pins.

- The operating nut shall be inserted into the cover plate or held in place by means of a bronze lock nut or screw and shall be sealed with an “O” ring in cover plate and cap or operating nut.
- The operating nut and cap nuts shall be standard 1-1/2 inch pentagonal.
- The operating stem thread shall be not less than 1-1/4 inch outside diameter and stem threads shall be lubricated by means of a grease connection or other means of lubrication. The threads of the stem must be sealed by a minimum of two "O" rings from the waterway and also from outside condensation.
- The operating nut must also have anti-friction bearings designed and installed to withstand the thrust developed during operation of the hydrant
- Not more than 5 parts should be removed for removal of the stem and all internal parts from the top of the standpipe (excluding bolts and nuts).
- Seat ring shall be bronze type that can be easily removed and/or replaced by unscrewing from another bronze ring.
- The hydrant valves and caps shall be furnished to open and close in the following directions that are standard with the City of Evansville:
 - The hydrant valves shall open clockwise and close counter- clockwise.
 - The caps shall be removed by turning counter-clockwise and tightened by turning clockwise.
 - There shall be no chains on the caps.
- Furnish 2 operating wrenches and 1 seat wrench for every 10 hydrants on the project.
- The hydrant shall be designed so that extensions can be added at a later date.
- Hydrants shall be furnished with mechanical joint accessories including bolts, glands, and gaskets. Bolts and nuts shall be made of ductile iron or cast iron (Corten or approved equal).
- The interior surface of the hydrant shoe shall be epoxy coated a minimum of 9 mils.
- The hydrant (seat valve) bottom plate shall be epoxy coated a minimum of 9 mils.
- Fire hydrants and parts shall be manufactured and assembled in the continental United States.
- All fire hydrants fed by 8 inch and larger mains shall be all yellow. Fire hydrants fed by a 6 inch water main shall be all yellow with a green bonnet. Colors may be field applied by contractor as long as the coatings applied are equivalent to the coatings supplied by the manufacturer.

- Fire Hydrant brands acceptable to the Evansville Water and Sewer Utility are Kennedy, Mueller, Clow, and AVK. Any other brands must be approved in writing prior to installation.

5.4.1.2.7 Tapping Sleeves

- Tapping sleeves shall be constructed of Grade 18-8, Type 304 stainless steel with stainless steel (drop-in) bolts with stainless steel hex nuts. The heavy hex nuts must have special lubricating fluorocarbon coating, heat-sintered to prevent galling.
- Tapping sleeves shall be furnished with a gridded rubber gasket consisting of SBR compound for water service meeting ASTM D2000 80M4AA604. The gasket must provide 360-degree circumferential support and have 16-gauge stainless steel armors, a minimum of 2-1/4 inches wide, molded in place to span the gap between the two tapping sleeve sections. Sleeves over four inches (4") in size shall also have a cap flange gasket to provide the primary seal.
- Tapping sleeves shall be furnished with 3/4-inch test port with a stainless steel square head plug for easy use. The 3/4-inch test port shall be located at top dead center of the sleeve to aid in expelling all air during the hydrostatic test. The stainless steel flange must be recessed to accept standard tapping valves. The tapping sleeves shall be rated for a minimum of 150 psi working pressure, 225 psi test pressure.
- All stainless steel welds used in the construction of the sleeve shall conform to AWS codes and shall be passivated in order to return the surrounding stainless steel material to its original corrosive-resistant conditions. The flanges outlet section shall be double welded, inside and out, to provide maximum strength.
- The tapping sleeves shall be manufactured by the Ford Meter Box Company, Model FTSS, Mueller Model H304SS, JCM Model 432, or approved.

5.4.1.2.8 Tapping Saddles

- Tapping saddles shall be designed and manufactured for a working pressure of 200 psi. Saddle bodies shall be brass alloy. Saddle straps shall be corrosion resistant stainless steel alloy. Saddle gaskets shall be positively confined O-ring, Durometer Hardness 70 gaskets. The sleeve dimensions shall be such that the sleeves will not leak when installed on cast iron, ductile iron, or polyvinyl chloride pipe with outside diameter shown in ANSI/AWWA standards.
- Each saddle used for making a wet connection shall have a branch connection with a flange end. The inside diameter of each branch shall be oversized to permit entry and exist of tapping machine cutters. Each flange shall have a recess to center a tapping valve. Recesses shall meet the requirements of MSS SP-60. Flange dimensions and drilling shall meet the requirements of ANSI B 16.1.
- Each saddle used for making a dry connection shall have a branch connection with a flange or mechanical joint end. Flange dimensions and drilling shall meet the requirements of ANSI B 16.1. Nuts and bolts for flange joints shall meet the

requirements of ANSI/AWWA C 110 and be zinc-coated alloy steel. Gaskets shall comply with ANSI/AWWA C110, be full face and rubber, or as approved by the Engineer. Mechanical joints and accessories shall meet the requirements of ANSI/AWWA C111/A21.11.

- D. Tapping saddles shall be Ford Meter Box Model IOI BS, Model 202 BS, Mueller Model BR I S, Model BR2S, or approved equal.
- E. Gaskets used to seal joints between saddle bodies and tapped pipes shall be O-ring type, circular in cross section, and made of natural or synthetic rubber with a Durometer Hardness of 70 ± 5 .

5.4.1.2.9 Flange-Mechanical Joint Adaptors

- A. Flange-mechanical joint adapters shall be Ford Uni-Flange, EBAA Iron Flange adapter, or approved equal.

5.4.1.2.10 Restrained Expansion Couplings

- A. Restrained expansion couplings shall be manufactured of 65-45-12 ductile iron conforming to the material requirements of ASTM A536 and ANSI / AWWA C153 / A21.53. Couplings shall have mechanical joints following ANSI/AWWA C111. All hardware shall be stainless steel.
- B. Each expansion coupling shall be pressure tested prior to shipment against its own restraint to a minimum of 350 psi.
- C. Each flexible expansion coupling shall consist of an expansion joint designed and cast as an integral part of a ball and socket type flexible joint, having a minimum per ball deflection of 15° and 4-inches minimum expansion.
- D. All internal surfaces (wetted parts) shall be lined with a minimum of 15 mils of fusion bonded epoxy conforming to the applicable requirements of ANSI/AWWA C2 I 3. Sealing gaskets shall be constructed of EPDM. The coating and gaskets shall meet ANSI/NSF-61.
- E. All external surfaces shall be coated with a catalyzed coal tar epoxy conforming to the material requirements of AWWA C2I 0. Install polyethylene encasement as described this section.
- F. Restrained expansion couplings shall be EX-TEND as manufactured by EBAA Iron, Inc.

5.4.1.2.11 Polyethylene Wrap

- A. Provide polyethylene encasement wrap for all ductile iron pipe, fittings and appurtenances to prevent contact between the ductile iron piece and the surrounding bedding material and backfill.
- B. Polyethylene encasement materials shall be in accordance with AWWA C105, and shall be in either tubes or sheets.

5.4.1.2.12 Air and Vacuum Valve Chambers

- A. Air and vacuum valves greater than two inch shall have 48 inch diameter precast concrete manhole barrel chambers with precast concrete flat slab tops. Precast manhole barrels shall meet the requirements of ASTM C478. One and two inch air and vacuum valves may be contained in a 30 inch meter pit.
- B. Air and vacuum chamber access frames and covers shall be nominal 24 inch cast iron casting, minimum 7 inches in height with the word "WATER" cast into each cover.

5.4.1.2.13 Grout

- A. For water line abandonment, Grout (also known as flowable fill) for filling abandoned mains shall be cementitious material, aggregate and water. Mix design shall conform to Section 213 of the Indiana Department of Transportation Standard Specifications (latest edition). Flowable fill shall be machine-excavatable with a minimum 28-day compressive strength of 50 psi and a maximum 28-day compressive strength of 150 psi.

5.4.1.2.14 Location (Tracing) Wire

- A. Location wire for PVC pipe shall be 12 AWG - Solid Core RHW or RHH underground copper cable. Location wire for open cut applications may also use the same wire required for directional drilling applications.
- B. Location wire used in directional drilling applications shall be 12 AWG- Solid CCS Directional Drill Tracer Wire, 45 MIL HDPE, 30 Volt, Direct Burial Only Wire, part number 1245B-EHS, manufactured by Copperhead Industries, LLC.
- C. Tracer wire connections shall be made using part number 3WB-O I manufactured by Copperhead Industries, LLC.

5.4.1.3 Execution**5.4.1.3.1 Inspection**

- A. The quality of all materials, the process of manufacture and the finished products shall be subject to inspection and approval by the Utility. Such inspection may be made at the place of manufacture, after delivery to the site or at both places; and the products shall be subject to rejection at any time for failure to meet any of the specifications' requirements, even though sample products may have been previously accepted as satisfactory at the place of manufacture.
- B. Prior to being installed, each pipe and fitting shall be carefully inspected. Those not meeting the specifications shall be rejected and removed immediately from the work.

5.4.1.3.2 Laying of Water Mains

- A. Proper tools and facilities shall be provided and used by the Developer's Contractor for safe working conditions.

- B. Lay and maintain pipe to the lines and grades shown on the drawings or to the minimum depth specified in this Article. Install fittings, valves and hydrants in the locations shown on the drawings.
- C. When the exact location of buried utilities is unknown and piping is to be constructed parallel and close to said utilities, adjust the alignment of the piping to least interfere with these utilities. This applies unless otherwise shown on the drawings or specified by the Engineer.
- D. Water mains shall be laid at least 10 feet horizontally from any existing sanitary sewer or sewage force main. The distance shall be measured from edge to edge of the pipe. Water mains crossing sanitary sewer or sewage force mains shall be laid to provide a minimum vertical distance of 18 inches between the outside of the water main and the outside of the sewer or force main. The 18-inch separation shall apply whether the water main is over or under the sewer or force main. Lay water mains at crossings of sewers and force mains so a full length of water main pipe is centered on the sewer or force main whenever possible. No water main shall pass through or come in contact with any part of a sanitary sewer manhole.
- E. Water main piping shall be laid at a depth that provides at least 4'-0" cover. These depths of cover apply unless otherwise depicted on the drawings or specified by the Engineer. Furthermore, cover shall be measured as the vertical distance from the top of the pipe to the finish grade elevation. Stone, concrete, or pavement is not considered cover.
- F. Laying of water mains shall meet the requirements of ANSI/AWWA C600, unless otherwise specified in this Section.
- G. Shape the bottom of the trench to give uniform circumferential support of the lower quarter of each pipe. Also, all trench excavation shall be in accordance with federal, state and local OSHA requirements.
- H. Do not lay pipe in water or when the trench or weather conditions are unsuitable for proper installation.
- I. As each length of pipe is placed in a trench, joint the pipe being laid to the previously laid pipe. Bring the pipe to correct line and grade. Secure the pipe in place with bedding tamped under the pipe. Tamp bedding up to the centerline of the pipe.
- J. Deflection from a straight line or grade shall not exceed the limits specified in this Section. If the alignment requires joint deflections in excess of the allowable deflection per joint, furnish and install fittings.
- K. Provide thrust restraint at horizontal and vertical deflection fittings and at tees, plugs, tapping sleeves and tapping saddles. Restraint shall be with restrained joint piping per restrained joint detail.

- L. Block the open end of the pipe at the close of each day's work or when otherwise unattended to prevent contamination from dirt or rain water and entry of any animal or foreign material.
- M. Lower pipe, fittings, valves and hydrants into the trench by hand, hoists or ropes or other suitable tools or equipment that will not damage products, coatings or linings. Do not drop or dump pipe, fittings, valves, or hydrants into the trench.
- N. Do not leave trash, debris, etc. in trenches or excavations.

5.4.1.3.3 Setting Valves, Valve Boxes, and Fire Hydrants

- A. Clean the interiors of valves and hydrants of foreign matter before installation. Verify that all bolts are snug. Inspect valves and hydrants in opened and closed positions to ensure all parts are in working condition.
- B. Set valves and valve boxes plumb. Center valve boxes on the valves or valve operators using centering devices. Locate valves outside the area of roads and streets where feasible. Tamp backfill around each valve box to a distance of 4 feet on all sides of the box or to the undisturbed trench face if less than 4 feet.
- C. Set hydrants plumb with the pumper nozzle facing the street. Set each hydrant to the bury line marked on each hydrant. The centerline of the outlet nozzles shall be at least 18 inches or at most 30 inches above finished grade at a hydrant. Install hydrant extensions where required to bring hydrant to proper elevation. Set each hydrant upon a slab of stone or concrete not less than 4 inches thick and 15 inches square. Compact the backfill around each hydrant to finish grade. Furnish and install a gate valve, valve box, and valve box alignment device in each hydrant branch connection. All piping between the main and the hydrant shall be restrained ductile iron pipe or ductile iron anchor couplings. In the field, apply two coats of yellow polyurethane epoxy to the body of the fire hydrants installed as well as two coats of the appropriate color (depending on main size) polyurethane epoxy to the bonnet. Bonnet colors shall be as follows depending on the size of the main feeding the hydrant: 8 inch or larger shall be yellow, 6 inch shall be green.

5.4.1.3.4 Connecting to Existing Mains

- A. The Contractor shall locate and verify exact size of all existing mains, both horizontally and vertically. Additionally, allow adequate time, after location and prior to making new connections, for changes in the connection location and size. Backfill excavation immediately after main is located and measured.
- B. Make each wet connection with a tapping valve and sleeve. Install and hydrostatically test each tapping valve and sleeve assembly to 150 psi for a minimum of 15 minutes prior to tapping the existing water main. Open and close tapping valves, and inspect tapping valves in both positions to ensure all parts are in working condition. To ensure that the tapping valve is open, inspect each tapping valve prior to connecting the tapping machine. Install watertight plug on the tapping valve outlet and backfill

excavation if new or existing water main is not connected to tapping valve within 48 hours.

- C. Make each dry connection with fittings and valves indicated on the drawings. Furnish and install sleeves required to complete connections. All required pipe, fittings, valves, tools and equipment shall be at the connection site prior to starting connection. Wash interior of new pipe, fittings and valves with a solution containing 50 mg/1 of chlorine, prior to making a connection. Make connections at night and on weekends when required. The Utility will operate all existing valves. Install sufficient water main and restrain joints so existing water mains can be put in service immediately after connection is completed. Inspect joints and eliminate leaks immediately after connection is completed and existing mains are put in service. Install watertight plugs on open ends of pipe and valves, and backfill excavation if new or existing water main is not connected to dry connection within 48 hours.

5.4.1.3.5 Jointing

A. Ductile Iron Push-On Joints

- Pipe must be cleaned and installed as specified by the manufacturer and ANSI/AWWA C600 requirements. Additionally, all lumps, blisters, excess bituminous coating and foreign material must be removed from the bell and spigot end of each pipe.
- For restrained push-on joints, move the loose retainer ring into position against the retainer bar on the spigot end of the pipe being installed. Loosely assemble the joint bolts and nuts.
- Deflect pipe after jointing, if deflection is required. The amount of deflection shall not exceed the limits shown in the following table:

TABLE 5-5: ALLOWABLE PIPE DEFLECTION (PUSH ON JOINT)

PIPE SIZE	MAXIMUM DEFLECTION ANGLE	MAX. DEFLECTION BASED ON 18-FOOT PIPE LENGTH
4"	5 degrees	18-1/2"
6"	5 degrees	18-1/2"
8"	5 degrees	18-1/2"
10"	5 degrees	18-1/2"
12"	5 degrees	18-1/2"
14"	4 degrees	15"
16"	4 degrees	15"
18"	3 degrees	11"
20"	3 degrees	11"
24"	3 degrees	11"

- For restrained push-on joints, pull the nuts to a uniform tightness by hand or with a short wrench. Do not pull the spigot of the pipe being installed against the back of the bell of the receiving pipe. For PVC pipe, use stop glands.

B. Mechanical Joints

- Pipe must be cleaned and installed as specified by the manufacturer and ANSI/AWWA C600 requirements. Additionally, all lumps, blisters, excess bituminous coating and foreign material must be removed from the bell and spigot end of each pipe.
- Evenly tighten the nuts using a torque wrench. The torque shall be within the range listed in the following table:

TABLE 5-6: MECHANICAL JOINT BOLT TORQUE RANGE

PIPE SIZE	BOLT SIZE	TORQUE RANGE
4" thru 24"	¾"	75 to 90 ft.-lbs.

- Deflect pipe, fittings or valves after jointing, if deflection is required. The amount of deflection shall not exceed the limits shown in the following table:

TABLE 5-7: PIPE DEFLECTION (MECHANICAL JOINT)

PIPE SIZE	MAXIMUM DEFLECTION ANGLE	MAX. DEFLECTION BASED ON 18-FOOT PIPE LENGTH
4"	8 degrees	31"
6"	7 degrees	27"
8"	5 degrees	20"
10"	5 degrees	20"
12"	5 degrees	20"
14"	3 degrees, 30 minutes	13-1/2"
16"	3 degrees, 30 minutes	13-1/2"
18"	3 degrees	11"
20"	3 degrees	11"
24"	2 degrees	9"

C. Threaded Joints

- Pipe must be cleaned and installed as specifically by the manufacturer and ANSI/AWWA C600 requirements. Additionally, all lumps, blisters excess bituminous coating and foreign material must be removed from the bell and spigot end of each pipe.
- Do not over tighten joints.
- Backing off made-up threaded joints to facilitate fit-up or alignment will not be permitted.

D. Flange Joints

- Pipe must be cleaned and installed as specified by the manufacturer and ANSI/AWWA C600 requirements. Additionally, all lumps, blisters, excess bituminous coating and foreign material must be removed from the bell and spigot end of each pipe.

- Do not over-torque nuts and bolts.

5.4.1.3.6 Restraining and Supports

- A. Thrust blocking is NOT an acceptable means of restraint.
- B. All fittings shall utilize EBAA Iron Megalug restraints or Utility approved equal.
- C. Piping shall be restrained in all directions from all fittings, valves or dead-ends in accordance with the recommended distances by EBAA Iron's Joint Restraint standards.

5.4.1.3.7 Air and Vacuum Valve Chambers

- A. Install air and vacuum valve chambers as indicated on the Utility approved drawings.
- B. Set frames and covers so that the top of the cover will be approximately flush with the finished grade, and make it watertight.
- C. Vent air and vacuum valve outlets to the surface with copper pipe matching the valve outlet size. Terminate vent outlets 3 feet above finished grade. Screen vents to prevent the entrance of insects. Paint air and vacuum valve vents yellow.

5.4.1.3.8 Hydrostatic Testing

- A. Test procedures shall meet the requirements of ANSI/AWWA C600.
- B. Hydrostatic tests shall be performed on all water mains installed. The Contractor shall make arrangements with the Utility for scheduling each test. Each test shall be performed on the day mutually agreed upon and in the presence of the Utility.
- C. The Contractor shall furnish any and all equipment, temporary piping, pumps, fittings, gauges and operating personnel necessary to conduct the tests. Water for testing shall be obtained by the Developer or his/her Contractor at no cost to the Utility.
- D. The water mains may be tested in sections between valves when there is one or more intermediary valves in a water main.
- E. Expel all air from the water main test section during the filling of the main and prior to the application of test pressure. Tap the water main at high points, if necessary, to release all air from the water main. Plug taps after the test is successfully completed. Plugs shall be watertight. Water should be introduced into the main at the lowest point in the line in order to facilitate the expulsion of air from the line.
- F. Test water mains at a static pressure of 150 psi over a period of not less than two (2) consecutive hours. The test will be considered successful when the pressure drop is zero. If the test fails, repair the leaks and repeat the test. Repair leaks and repeat the test until there is no pressure drop.

5.4.1.3.9 Flushing

- A. Flush water mains and fire hydrants prior to disinfection. Flush water mains with a flushing velocity of at least 2.5 feet per second. Following are flows required to provide a flushing velocity of 2.5 feet per second:

TABLE 5-8: REQUIRED FLOW FOR FLUSHING VELOCITY

PIPE SIZE	INSIDE DIAMETER	FLOW AT A 2.5 FT. PER SECOND VELOCITY
0-1/2"	0.622"	2.4 gpm
0-3/4"	0.824"	4.2 gpm
1-0"	1.050"	6.8 gpm
1-1/4"	1.380"	12 gpm
1-1/2"	1.610"	16 gpm
2-0"	2.070"	27 gpm
2-1/2"	2.470"	38 gpm
3"	3.07"	58 gpm
4"	4"	98 gpm
6"	6"	220 gpm
8"	8"	390gpm
10"	10"	620 gpm
12"	12"	880 gpm
14"	14"	1,200 gpm
16"	16"	1,600 gpm
18"	18"	2,000 gpm
20"	20"	2,500 gpm
24"	24"	3,600 gpm

- B. Flush water mains and hydrants until the water discharge is clear.

5.4.1.3.10 Disinfection

- A. All pipe shall be disinfected per AWWA C-651 (latest revision). All disinfection shall be completed by the contractor after the main has passed the hydrostatic test as witnessed by the Utility's designated inspector.
- B. After disinfection has been completed, a written letter requesting sampling shall be sent to the following:

Engineering Services Manager/Coordinator
 Evansville Water and Sewer Utility
 Attn: Engineering Dept.
 1931 Allens Lane
 Evansville, IN 47720

A map specifying the layout of the main along with the location of all chlorination taps, blow-off assemblies, and fire hydrants shall accompany the request for sampling. No mains will be sampled until the request and map is received.

- C. Water samples shall be tested by the Evansville Water and Sewer Utility at the Utility's lab. All sampling and bacteriological testing will be performed by the Utility and the costs incurred for such work shall be reimbursed by the Developer or his/her Contractor in accordance with the Administrative Requirements of the Utility. Contractor shall provide traffic control while the Utility collects the water samples, if required. The contractor must allow a minimum of 5 working days to receive the results of the bacteriological testing after the letter requesting sampling is received by the Utility

Engineering Department. Every time negative results are obtained from the testing procedure, a minimum of an additional 3 days will be required to retest. The contractor will be responsible for re-chlorinating the main if required by the Utility to receive satisfactory test results.

- D. Disinfect all new and repaired water mains prior to placing them in service. Disinfect pipe, fittings, valves and hydrants with a chlorine solution containing 200 mg/l ± 5 mg/l of available chlorine.
- E. Water services shall not be reconnected to the new water mains until the main has passed the disinfection test.
- F. The chlorinating material shall be sodium hypochlorite. Sodium hypochlorite shall have 5.25% to 14.7% available chlorine. Placing chlorine tablets in the mains during construction is NOT an acceptable method of disinfection. The following table shows the quantity of chlorine or hypochlorite required to produce 50 mg/l of available chlorine per 100 feet of pipe. The quantities as shown in the table shall be multiplied by 4 to obtain the appropriate solution of 200 mg/l.

TABLE 5-9: CHLORINE REQUIRED PER 100 FEET OF PIPE

PIPE SIZE	INSIDE DIAMETER	POUNDS		OUNCES			QUARTS	
		Cl ₂	Ca(OCl) ₂ (70%)	Ca(OCl) ₂ (70%)	NaOCl (14.7%)	NaOCl (5.25%)	NaOCl (14.7%)	NaOCl (5.25%)
0-1/2"	0.622"	0.00066	0.00094	0.015	0.072	0.20	0.0022	0.0063
0-3/4"	0.824"	0.0012	0.0017	0.026	0.13	0.35	0.0039	0.011
1-0"	1.050"	0.0019	0.0027	0.043	0.20	0.57	0.0064	0.018
1-1/4"	1.375"	0.0032	0.0046	0.074	0.35	0.99	0.011	0.031
1-1/2"	1.610"	0.0044	0.0063	0.10	0.48	1.3	0.015	0.042
2-0"	2.070"	0.0073	0.010	0.17	0.79	2.2	0.025	0.069
2-1/2"	2.470"	0.010	0.015	0.24	1.1	3.2	0.035	0.099
3"	3.070"	0.016	0.023	0.37	1.7	4.9	0.055	0.15
4"	4"	0.027	0.039	0.62	3.0	8.3	0.093	0.26
6"	6"	0.061	0.087	1.4	6.7	19	0.21	0.58
8"	8"	0.11	0.16	2.5	12	33	0.37	1.0
10"	10"	0.17	0.24	3.9	19	52	0.58	1.6
12"	12"	0.24	0.35	5.6	27	75	0.83	2.3
14"	14"	0.33	0.48	7.6	36	100	1.1	3.2
16"	16"	0.44	0.62	10	47	130	1.5	4.1
18"	18"	0.55	0.79	13	60	170	1.9	5.2
20"	20"	0.68	0.97	16	74	210	2.3	6.5
24"	24"	0.98	1.40	22	110	300	3.3	9.3

- G. Tap water mains where required to inject chlorine solution into all pipe, fittings, valves and hydrants installed and repaired. Inject chlorine solution into water mains. Leave the chlorine solution in the water mains for 24 hours or longer. Open and close valves in lines being disinfected several times during contact period
- H. Bacteriological Tests – The water main shall be tested for bacteriological quality after disinfection and final flushing. Two or more successive sets of bacteriologically

satisfactory samples taken at 24-hour intervals must be recorded before the facilities are released for use. Bacteriological testing shall meet the requirements of the applicable regulatory agency. Disinfection shall be repeated if the piping is not bacteriologically acceptable. Repeat disinfection and testing until the mains are approved for service by the applicable regulatory agency.

- I. Hose connections on fire hydrants shall not be used for collecting samples. Contact the applicable regulatory agency for sampling criteria and procedures.
- J. The time for disinfection bacteriological testing, and approval of the main for service shall be included in the contract time.
- K. The Contractor shall provide assistance to the Utility when collecting the samples. Assistance shall include providing traffic control and exposing sampling points.

5.4.1.3.11 Existing Valve Operation

- A. When it is necessary to operate valves on the existing water system for tie-ins, shut-downs, etc., the contractor shall be responsible for coordinating valve operating with the Engineering department of the Evansville Water and Sewer Utility.
- B. After the engineering department provides a location of all valves to be operated, it is the contractor's responsibility to verify that all valves are accessible and operable prior to needing them for the shut-down. The engineering department shall be given 24 hours' notice prior to the operation of any valves on the existing system.
- C. It is the contractor's responsibility to notify all residential customers that will be affected by the shut-down with a minimum of 24 hours' notice prior to the shut-down. It is the contractor's responsibility to notify all commercial business affected by the shut-down with a minimum of 48 hours' notice prior to the shut-down.
- D. Proper notice shall include personal contact with the owner if possible or posting of "door hangers" in a conspicuous location upon the property. The notice shall include at a minimum; the name and contact information of the contractor performing the shut-down, the date and time the water will be shut-down, and the date and time the water is expected to be turned back on and service restored. Instructions indicating proper procedures for evacuating any air or contaminants that may have entered the system during the shut-down period shall also be included on the notice to customers.

5.4.1.3.12 Completion Scheduling

- A. Complete water mains as they are installed. Test, flush, sterilize, and place in service each part of the water main which is complete and can be placed in service without preventing work to continue on uncompleted parts of the new water mains.
- B. Install restrained caps with thrust blocks on existing mains by shutting off the water supply and cutting the existing mains. This work shall be performed after the new water mains are in service. Contractor shall minimize time of water shut-off and shall coordinate water shut-off with the Utility and affected customers.

- C. Pump flowable fill into abandoned water mains into sections 400 feet or shorter. The flowable fill shall fill the entire abandoned water main.

SECTION 6: Standard Details

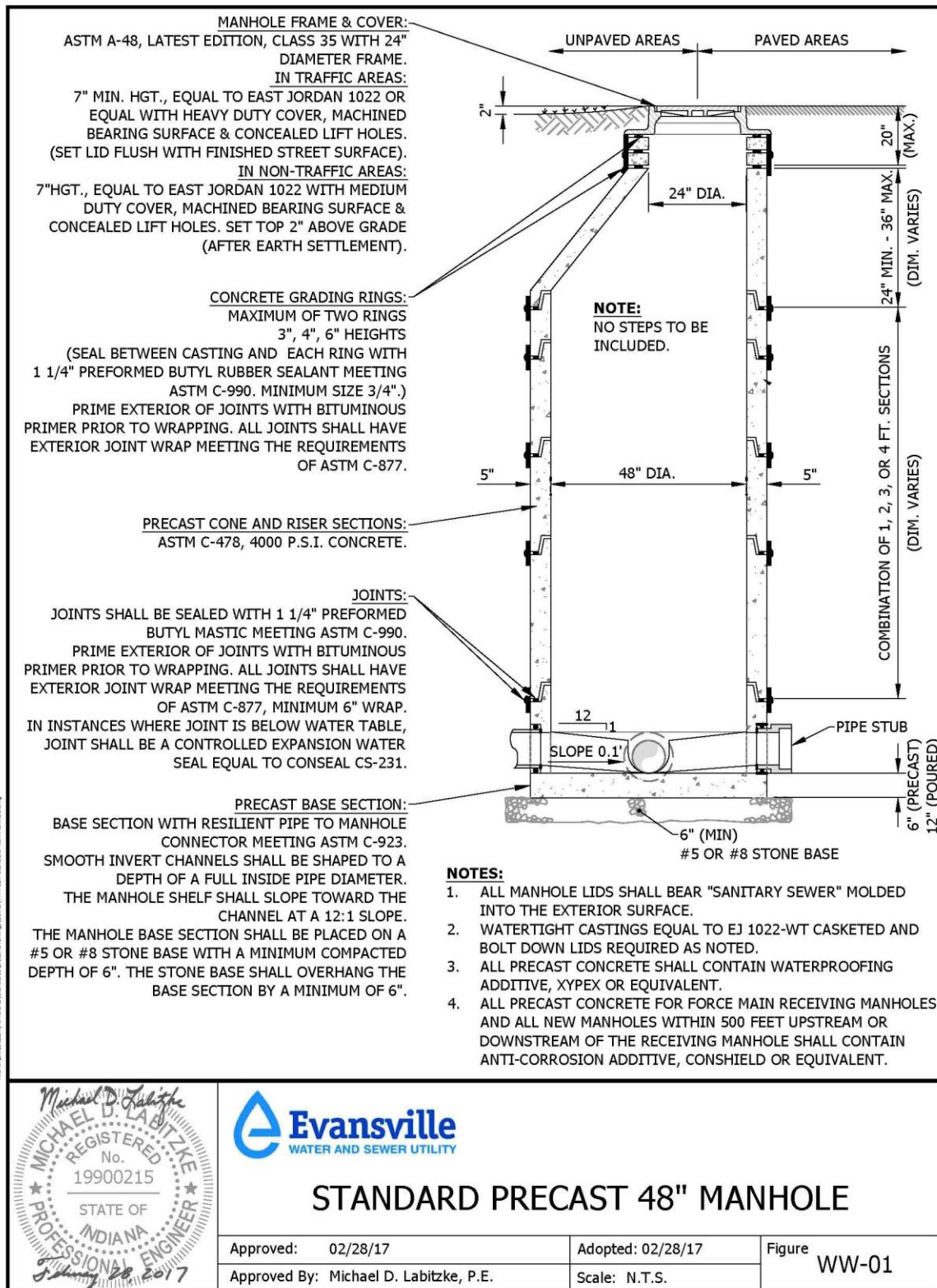

File: 1:PRECAST 48" (Standard Detail) Drawing (Sewer) (WWS) Standard also Non-holding

Michael D. Labitzke
REGISTERED PROFESSIONAL ENGINEER
No. 19900215
STATE OF INDIANA
January 26 2017



STANDARD PRECAST 48" MANHOLE

Approved: 02/28/17	Adopted: 02/28/17	Figure WW-01
Approved By: Michael D. Labitzke, P.E.	Scale: N.T.S.	

Figure 6-1: Detail WW-01 Standard Precast 48" Manhole

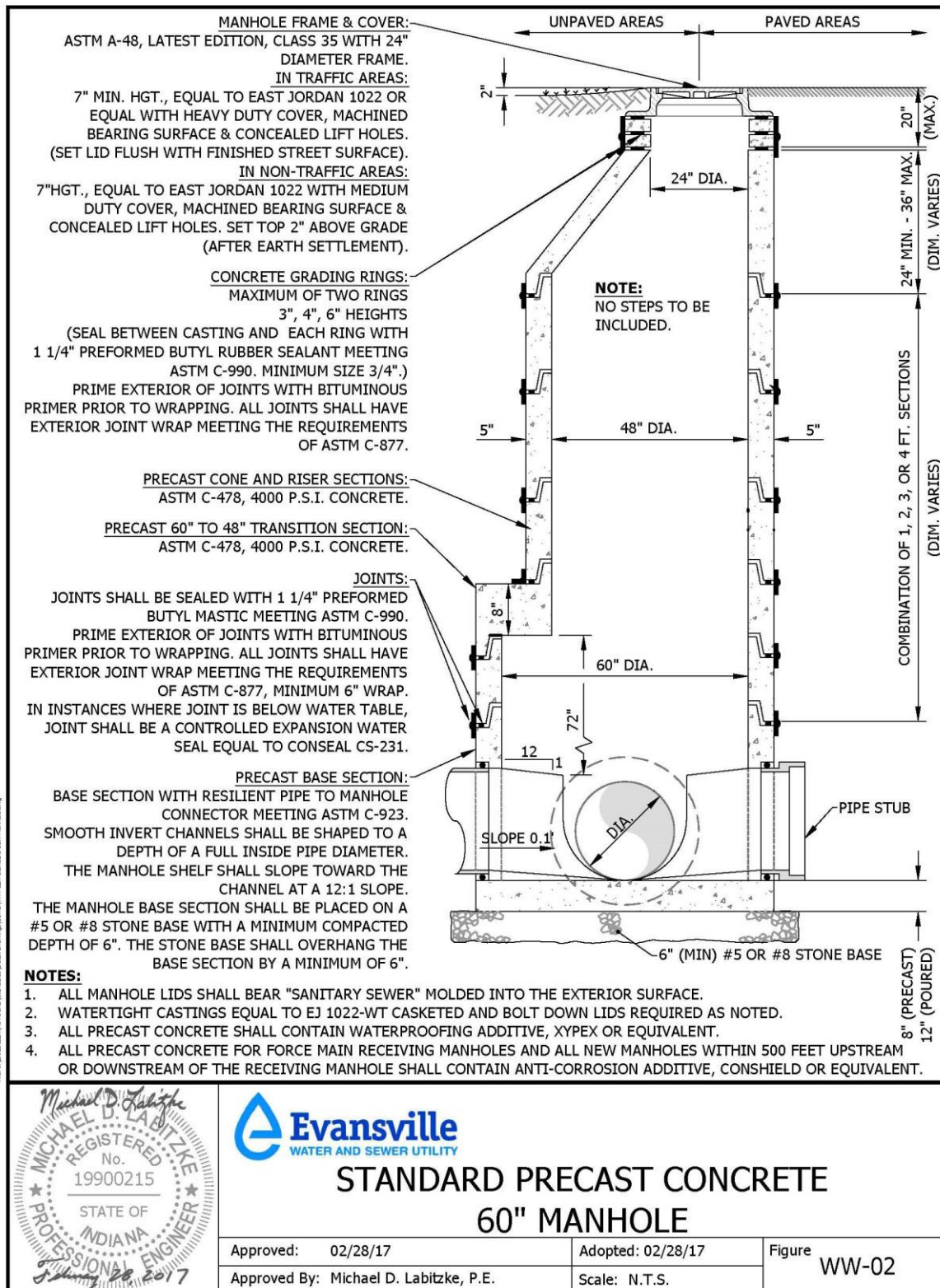

File: J:\ENR\2017\11\20\Standard\Detail Drawings\Manhole\WW-02 Standard 60" Manhole.dwg

Michael D. Labitzke
REGISTERED
No. 19900215
STATE OF INDIANA
PROFESSIONAL ENGINEER
February 2017



**STANDARD PRECAST CONCRETE
60" MANHOLE**

Approved: 02/28/17	Adopted: 02/28/17	Figure WW-02
Approved By: Michael D. Labitzke, P.E.	Scale: N.T.S.	

Figure 6-2: Detail WW-02 Standard Precast Concrete 60" Manhole

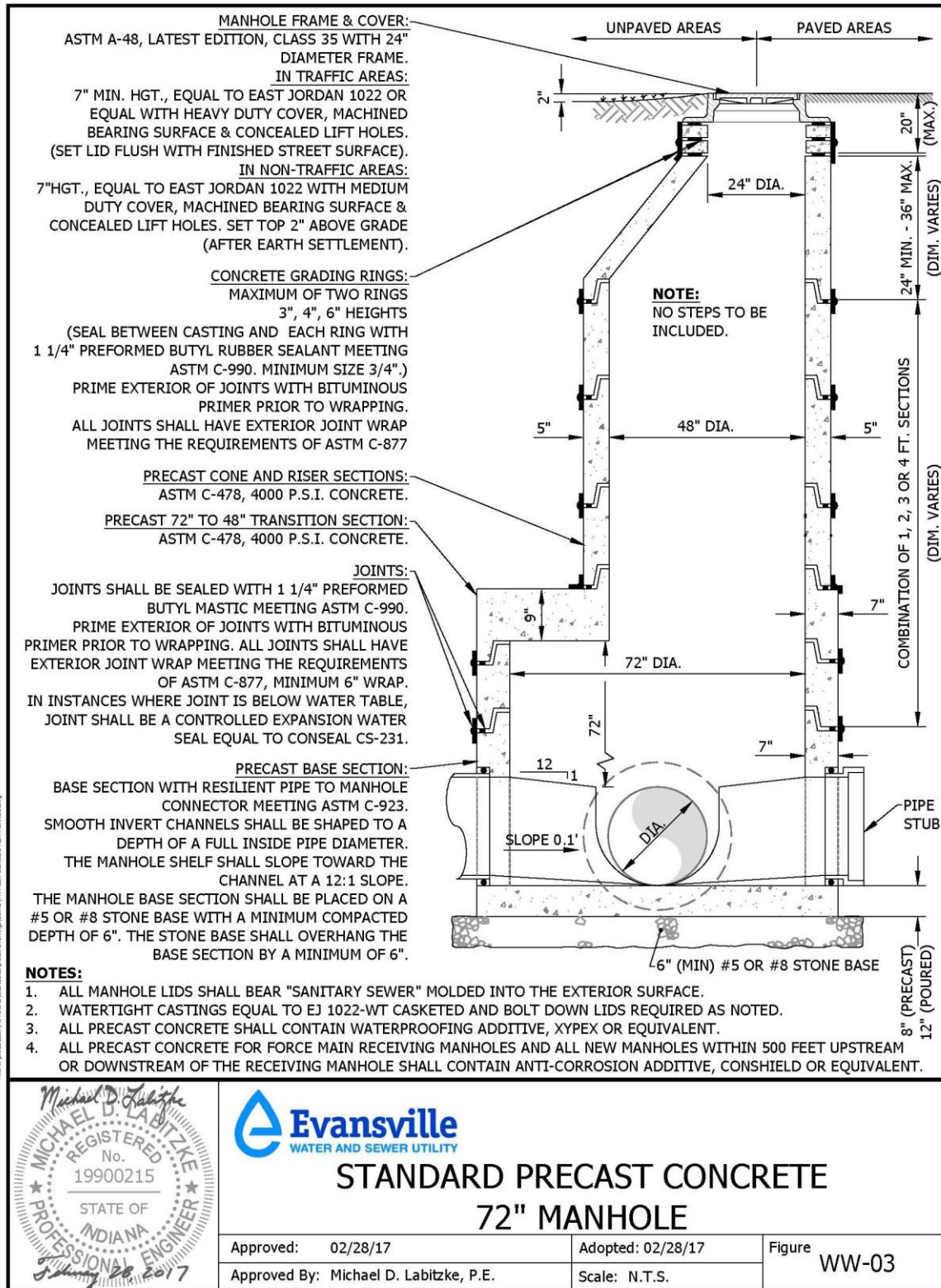

File: J:\ENGINEER\AUTOCAD\Standards\Detail\Drawings\Water\WW-03_Standard_72in_Manhole.dwg

Michael D. Labitzke
REGISTERED
No. 19900215
STATE OF INDIANA
PROFESSIONAL ENGINEER
February 28, 2017

Evansville
WATER AND SEWER UTILITY

STANDARD PRECAST CONCRETE 72" MANHOLE

Approved: 02/28/17	Adopted: 02/28/17	Figure WW-03
Approved By: Michael D. Labitzke, P.E.	Scale: N.T.S.	

Figure 6-3: Detail WW-03 Standard Precast Concrete 72" Manhole

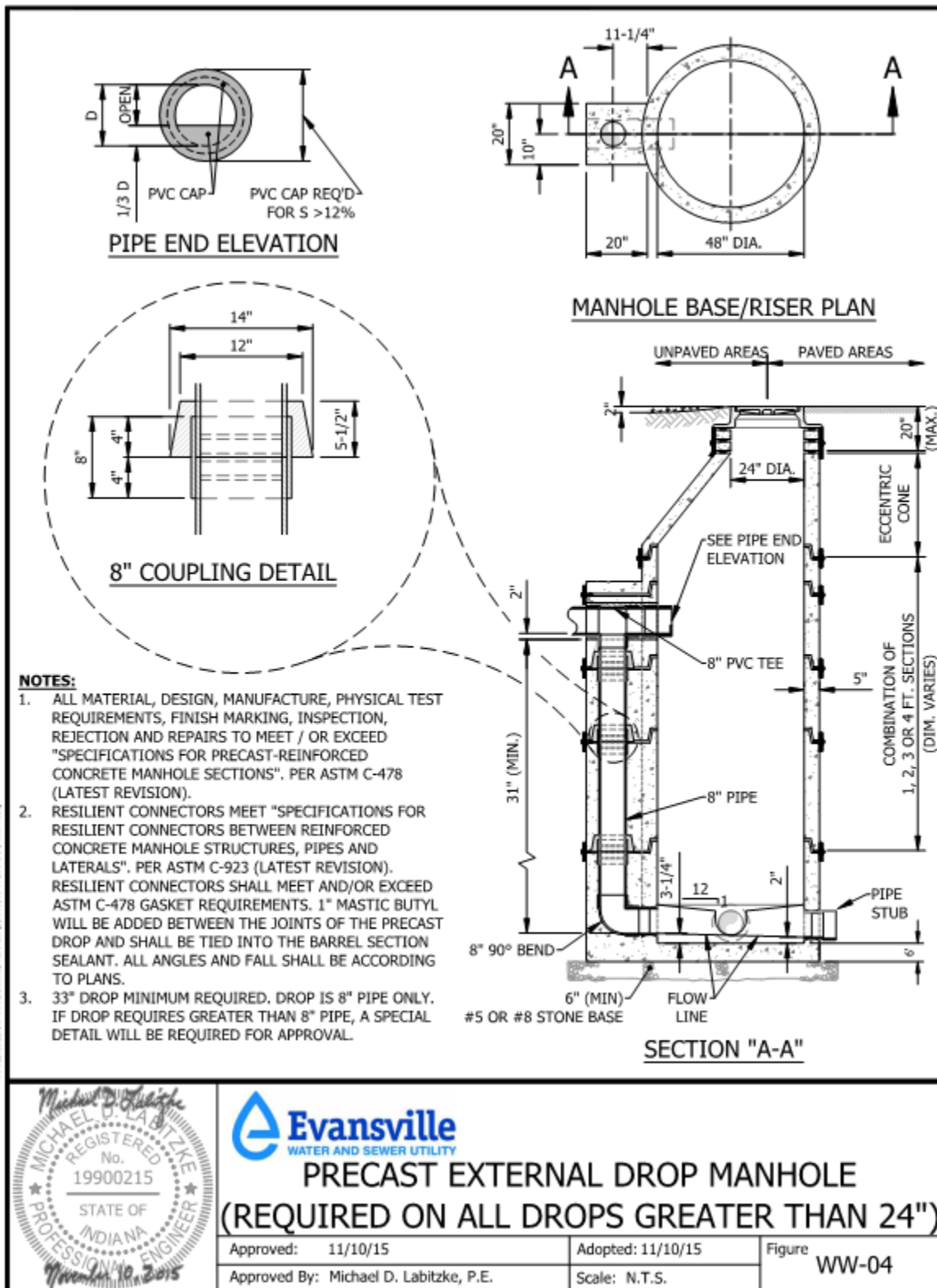
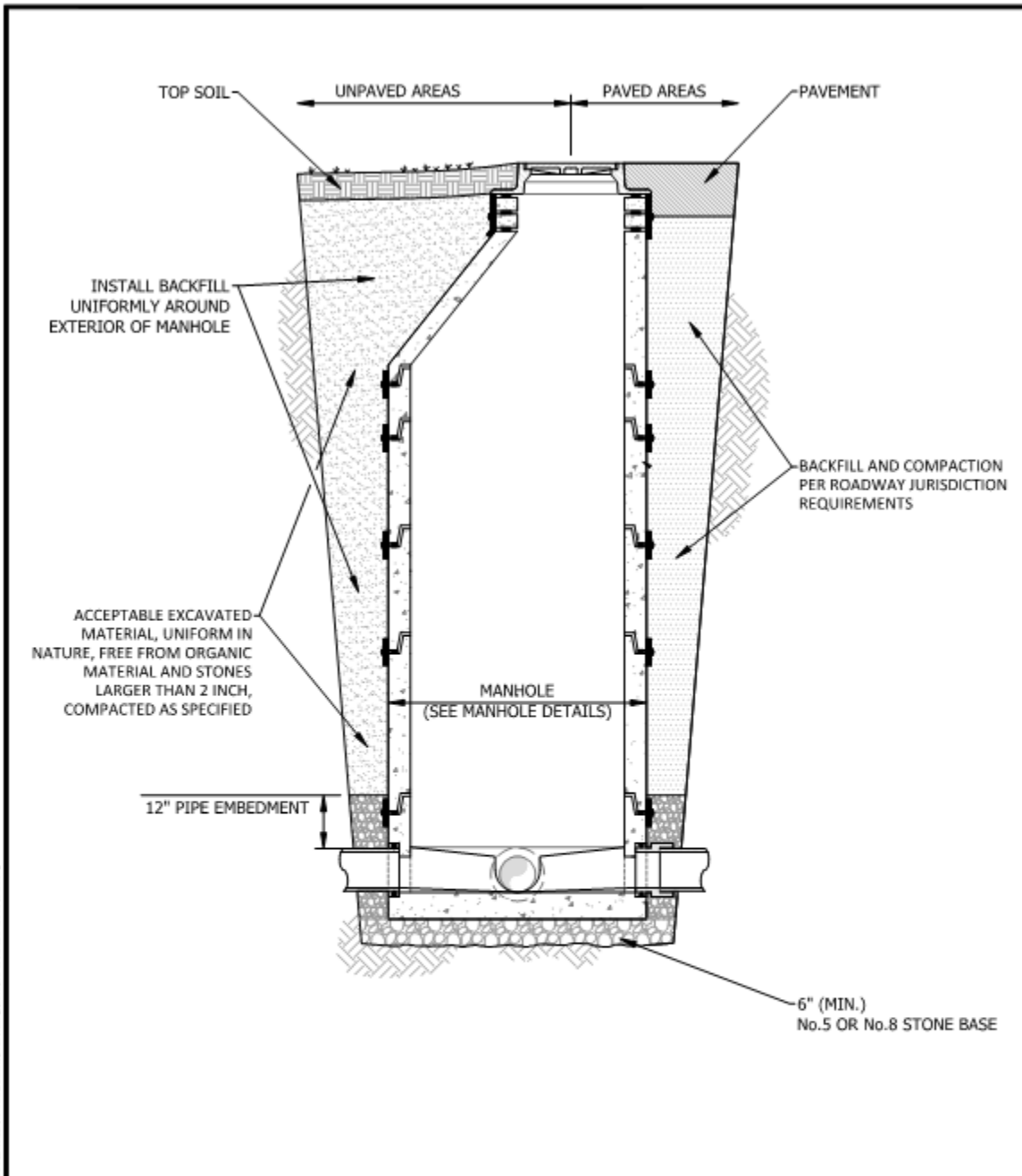

Figure 6-4: Detail WW-04 Precast External Drop Manhole



			<p align="center">STANDARD MANHOLE BACKFILL</p>
	Approved: 11/10/15 Approved By: Michael D. Labitzke, P.E.	Adopted: 11/10/15 Scale: N.T.S.	

Figure 6-5: Detail WW-05 Standard Manhole Backfill

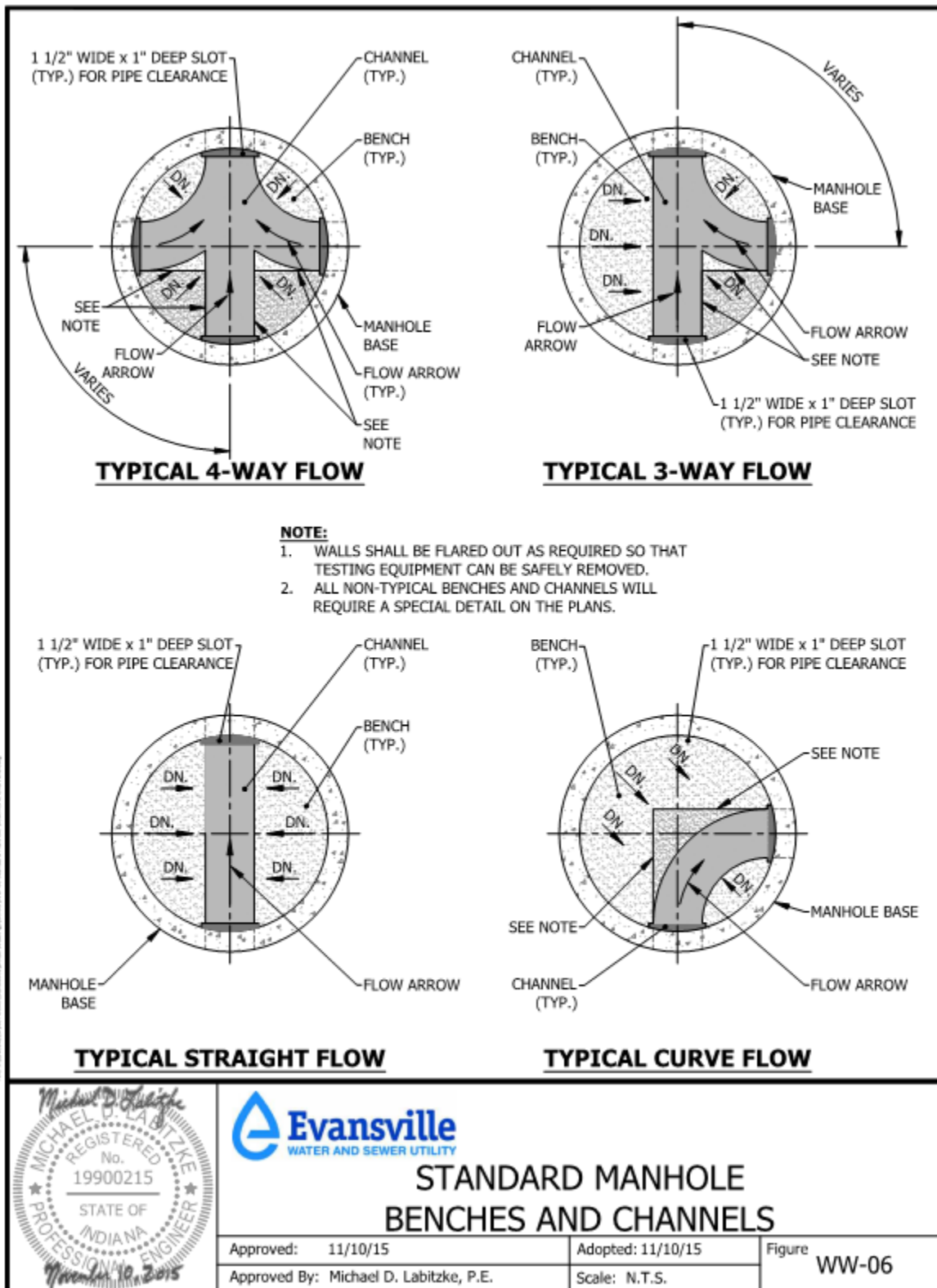

Figure 6-6: Detail WW-06 Standard Manhole Benches and Channels

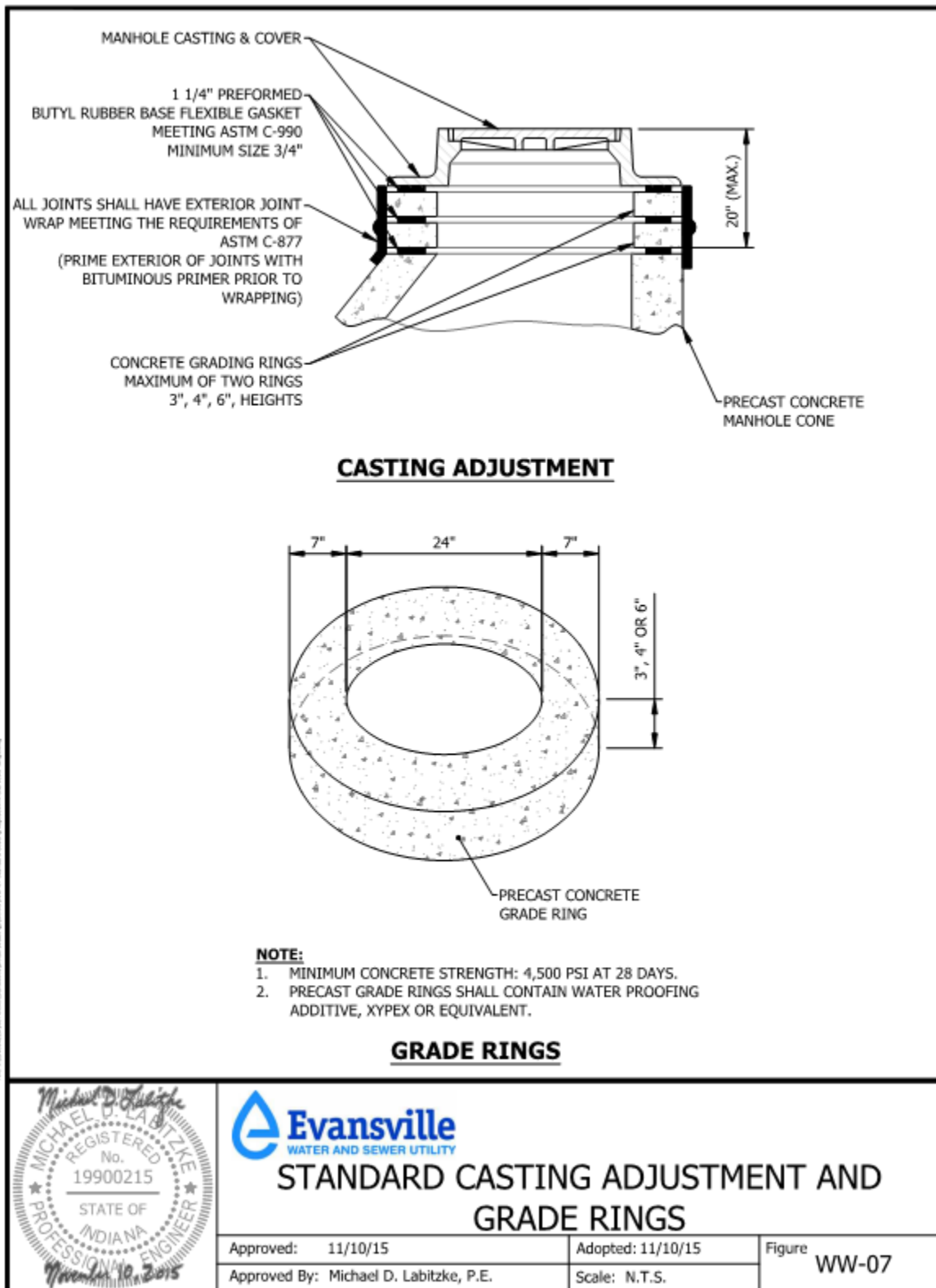
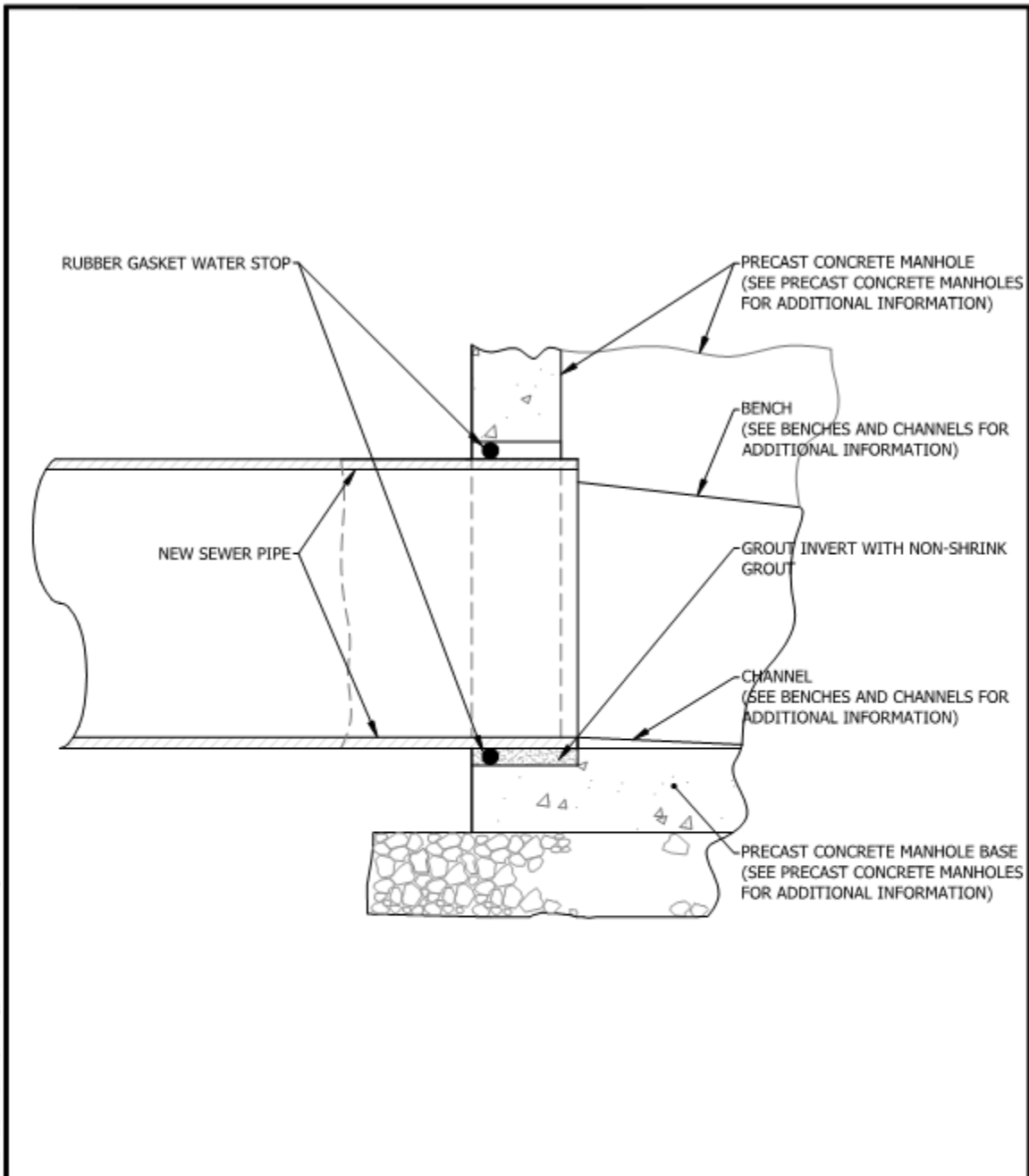
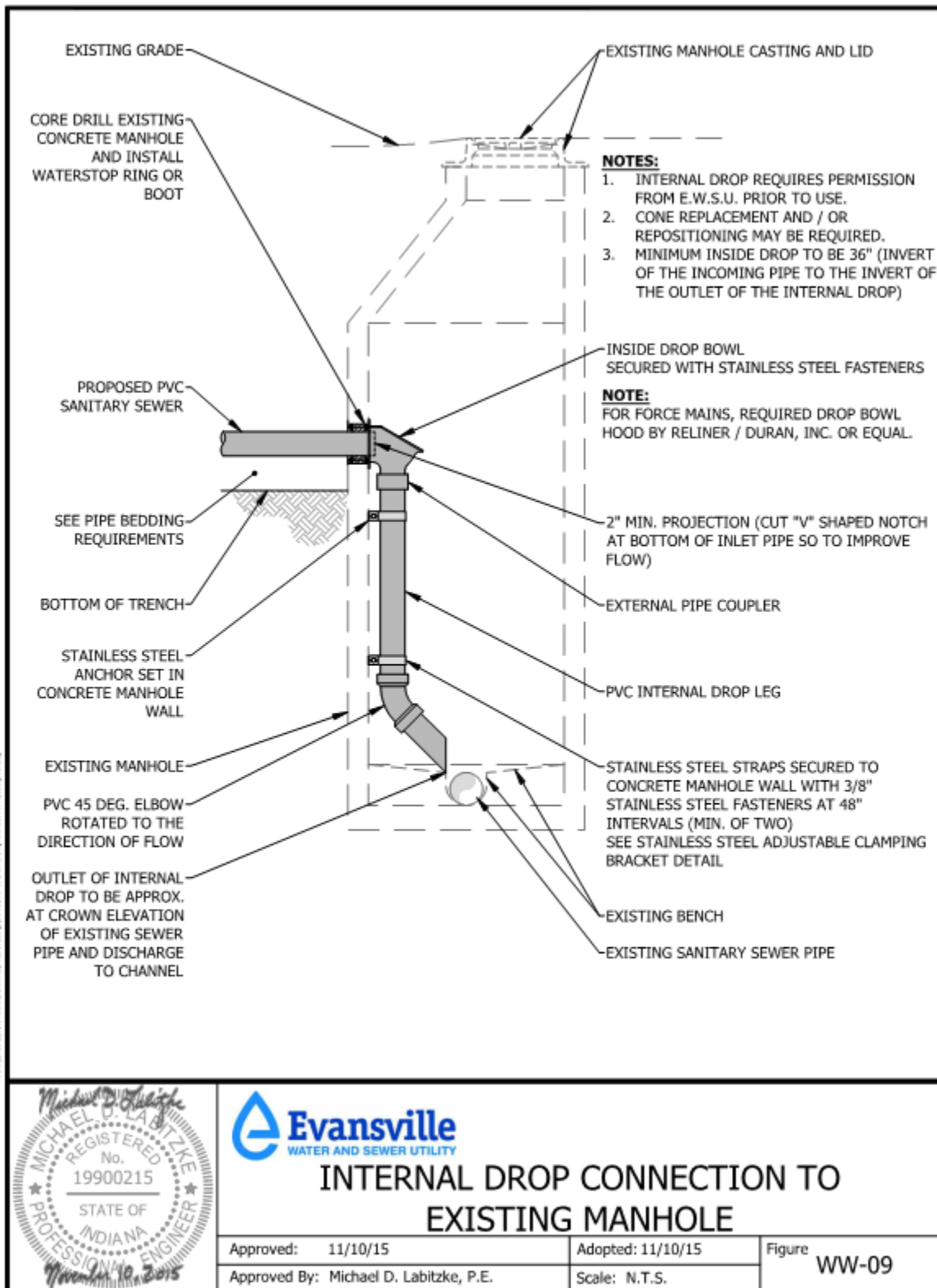

Figure 6-7: Detail WW-07 Standard Casting Adjustment and Grade Rings



			<h3>STUB-OUT AT MANHOLE</h3>	
	Approved: 11/10/15 Approved By: Michael D. Labitzke, P.E.	Adopted: 11/10/15 Scale: N.T.S.	Figure WW-08	

Figure 6-8: Detail WW-08 Stub-Out at Manhole



INTERNAL DROP CONNECTION TO EXISTING MANHOLE

Approved: 11/10/15	Adopted: 11/10/15	Figure WW-09
Approved By: Michael D. Labitzke, P.E.	Scale: N.T.S.	

Figure 6-9: Detail WW-09 Internal Drop Connection to Existing Manhole

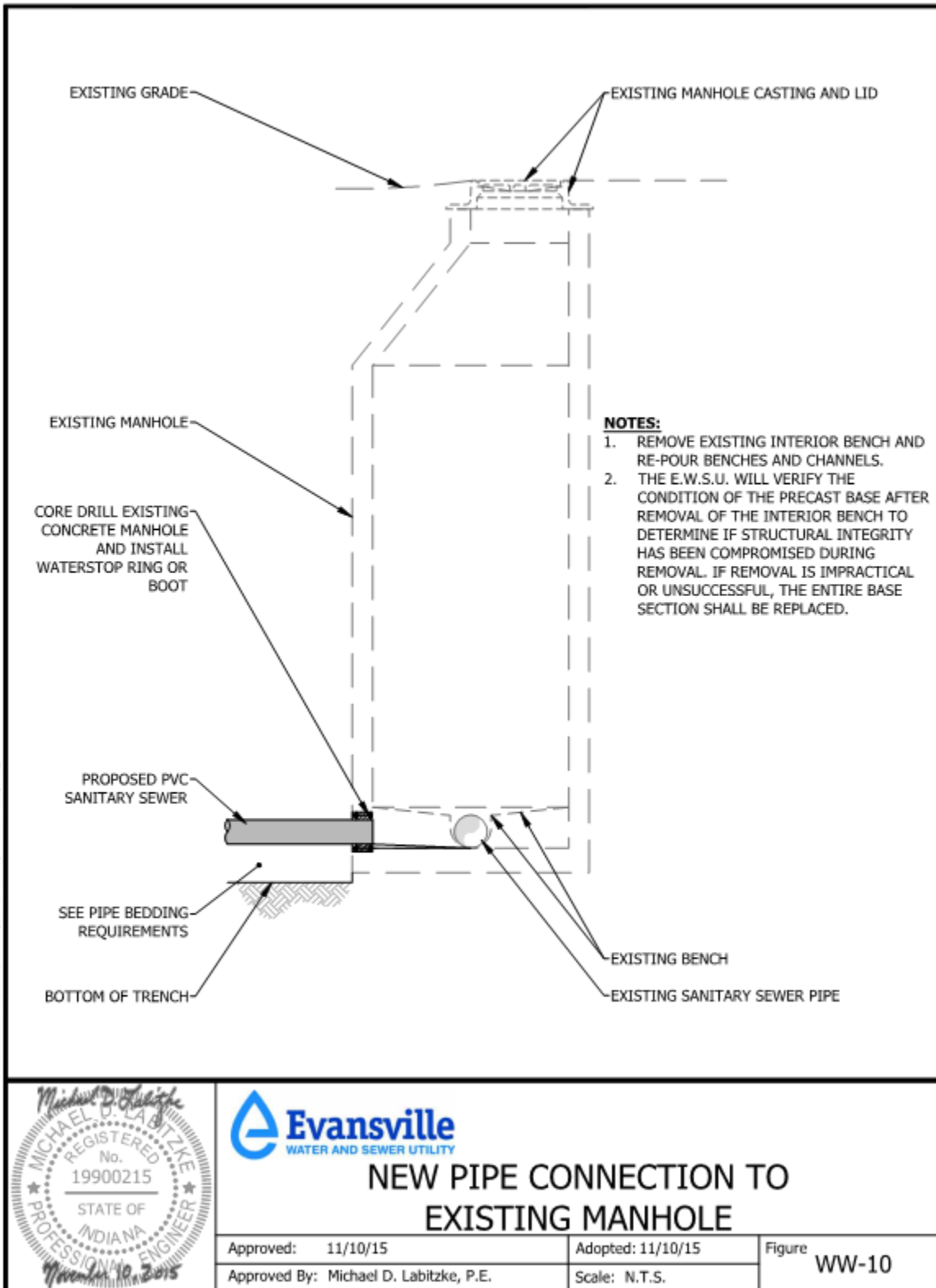

NEW PIPE CONNECTION TO EXISTING MANHOLE

Approved: 11/10/15	Adopted: 11/10/15	Figure WW-10
Approved By: Michael D. Labitzke, P.E.	Scale: N.T.S.	

Figure 6-10: Detail WW-10 New Pipe Connection to Existing Manhole

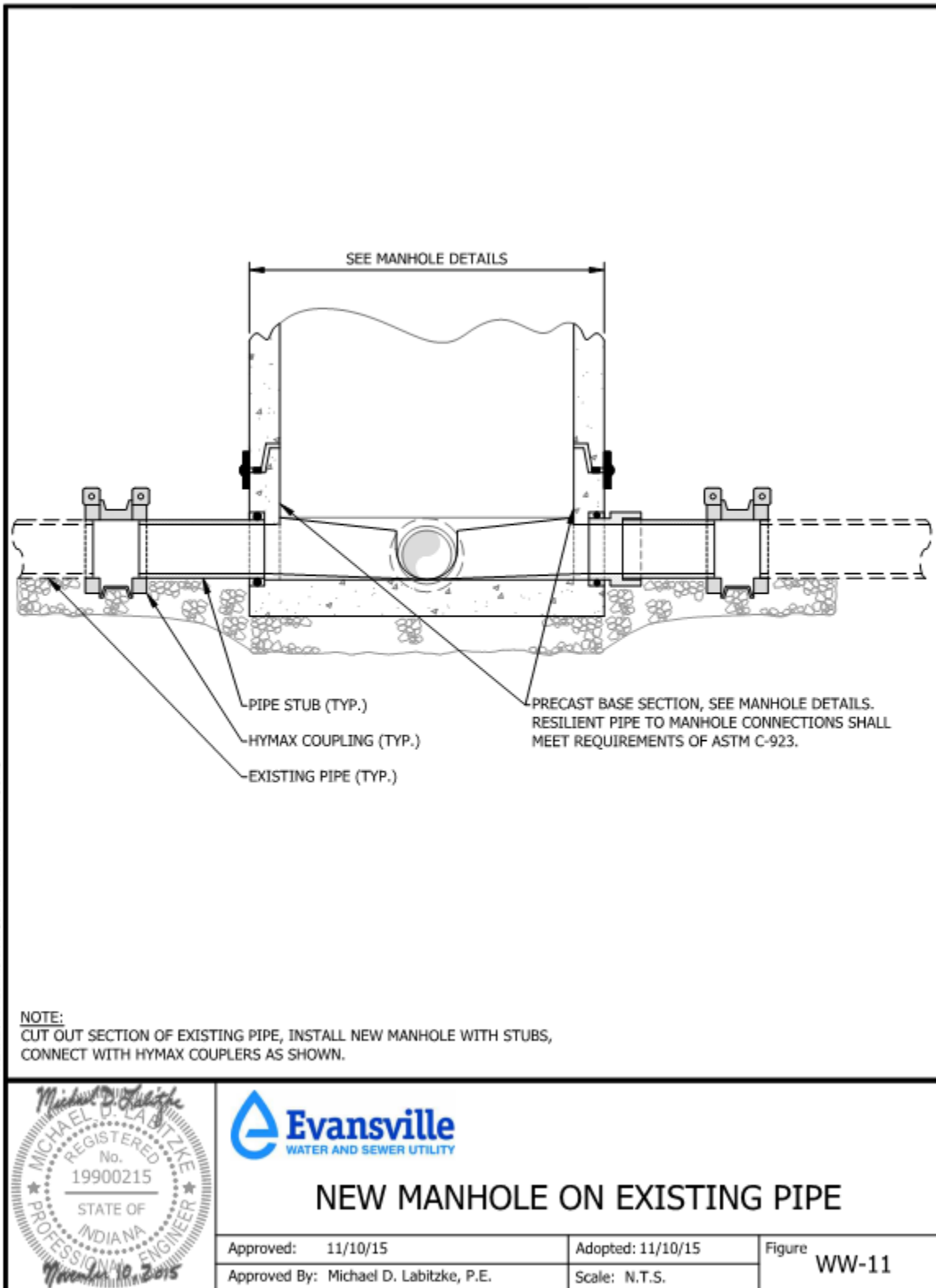

Figure 6-11: Detail WW-11 New Manhole on Existing Pipe

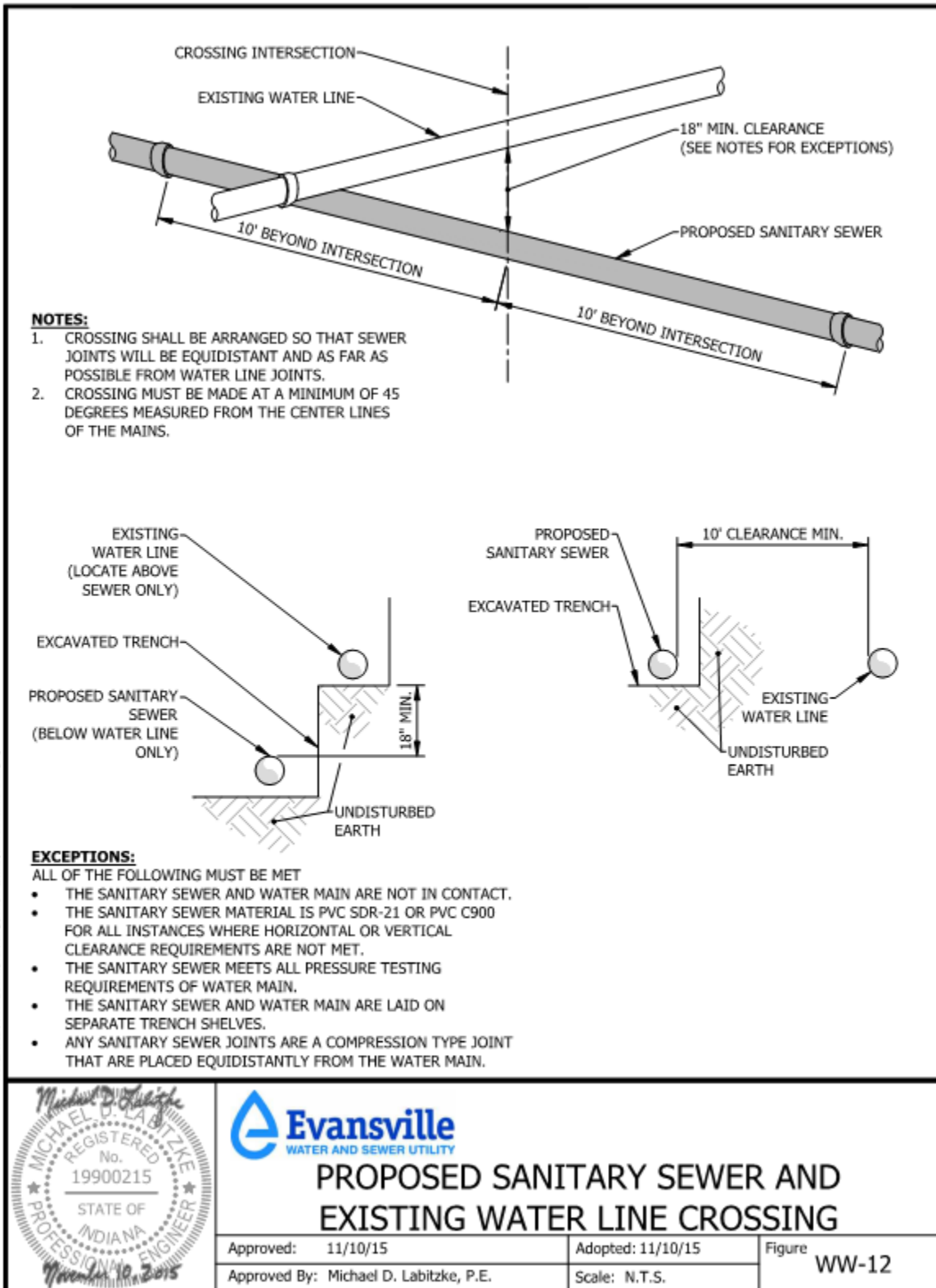

Figure 6-12: Detail WW-12 Proposed Sanitary Sewer and Existing Water Line Crossing

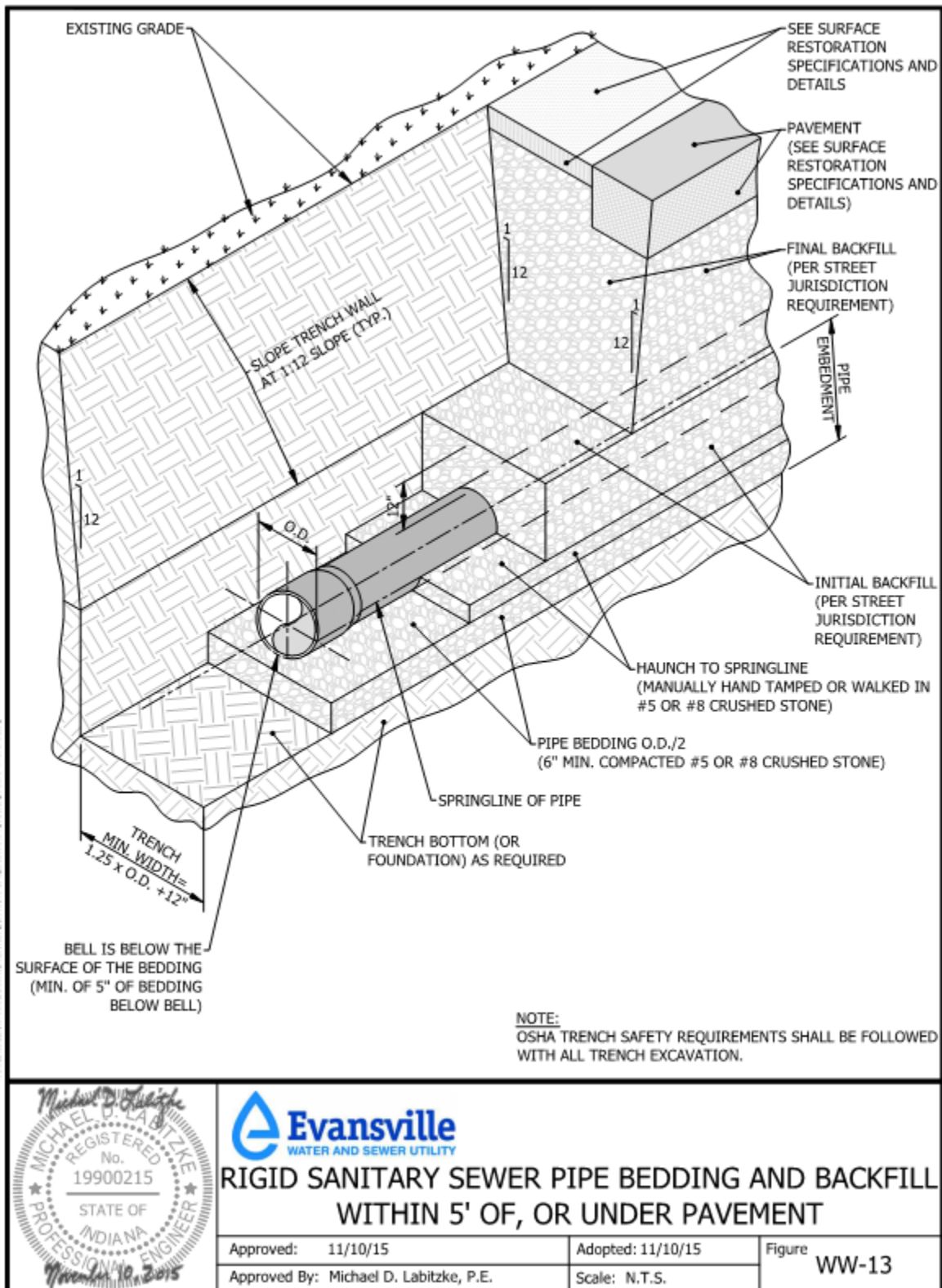

Figure 6-13: Detail WW-13 Rigid Sanitary Sewer Pipe Bedding and Backfill Near or Under Pavement

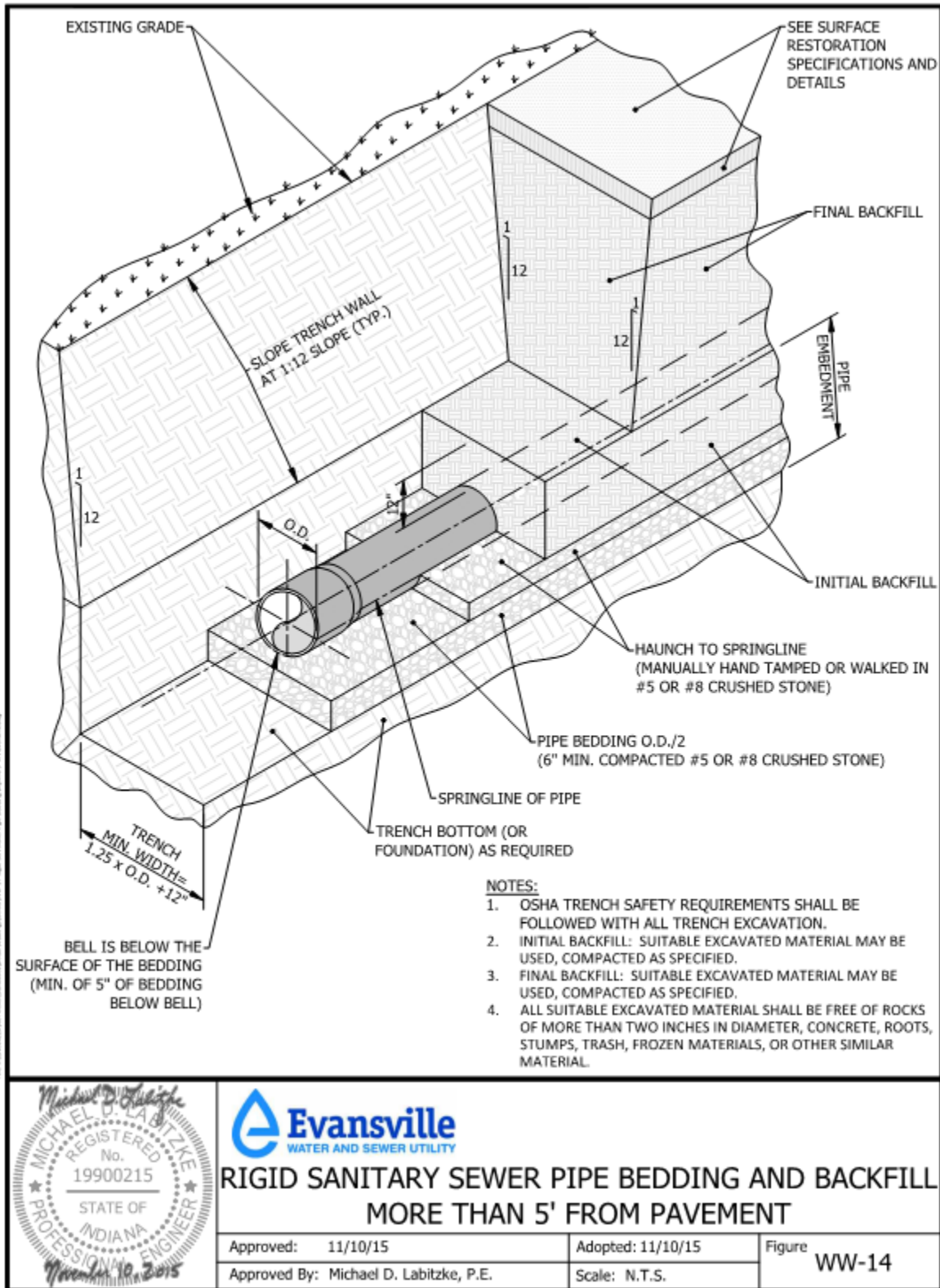

Figure 6-14: Detail WW-14 Rigid Sanitary Sewer Pipe Bedding and Backfill Outside of Pavement

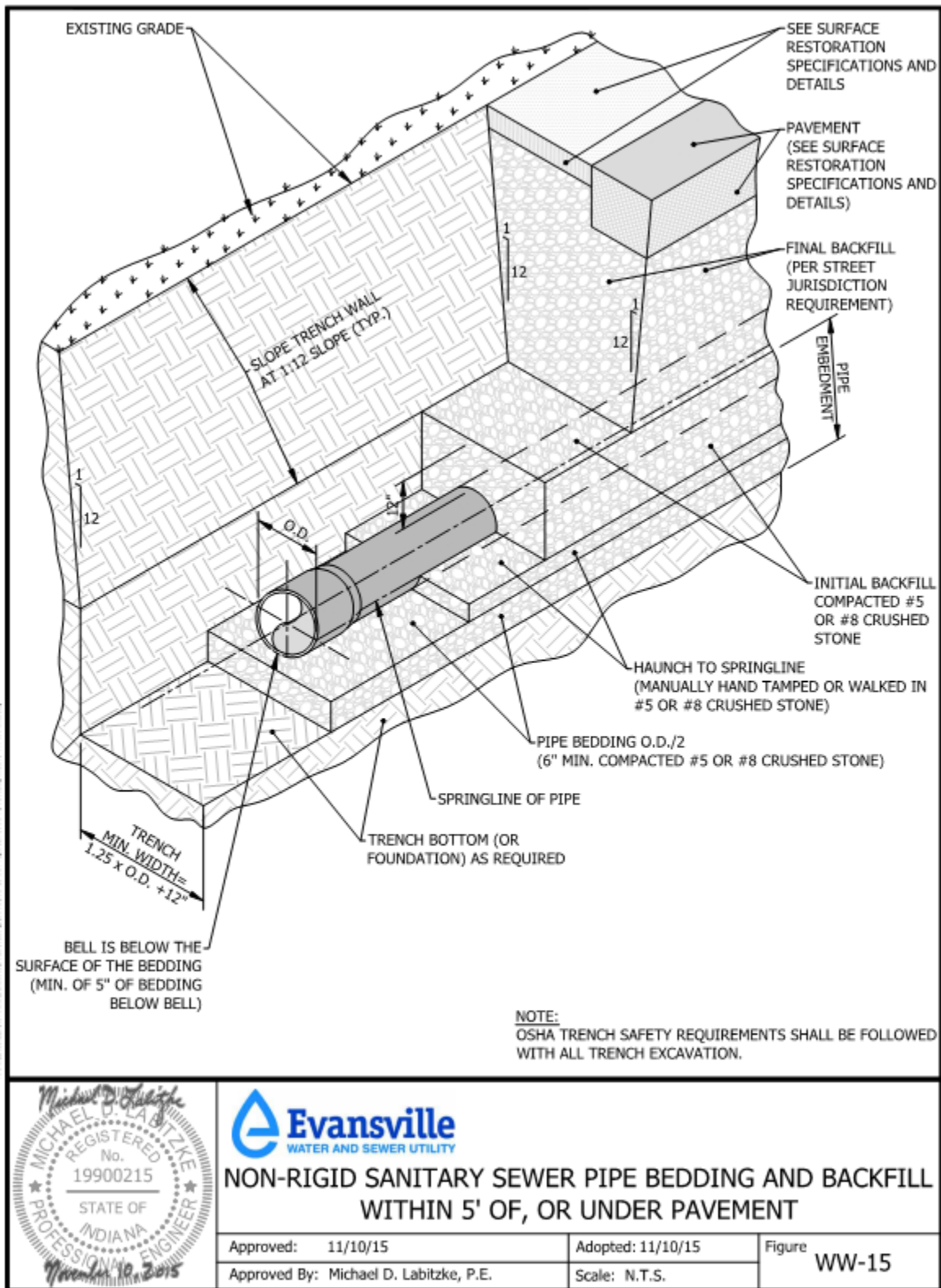

Figure 6-15: Detail WW-15 Non Rigid Sanitary Sewer Pipe Bedding and Backfill Near or Under Pavement

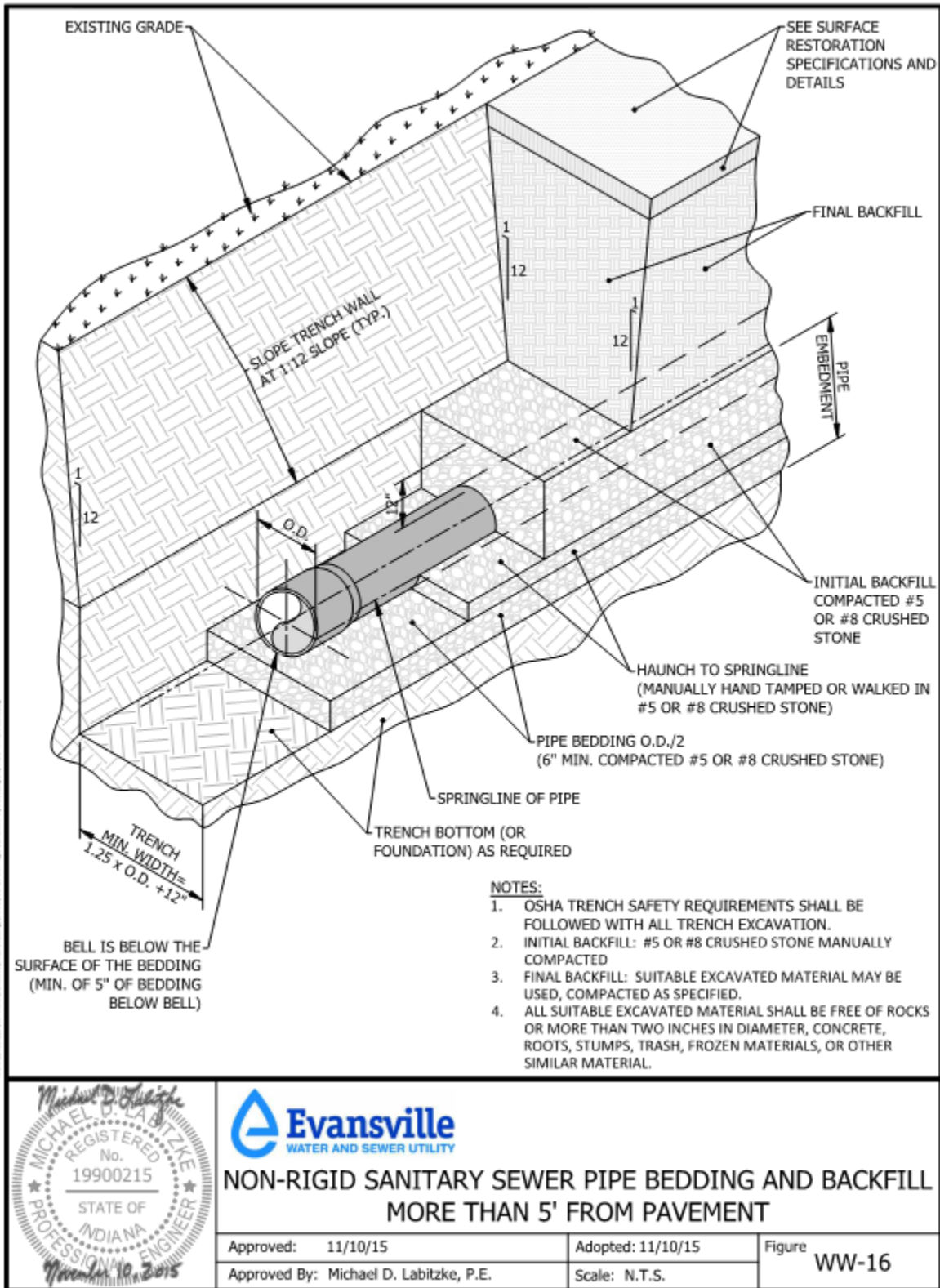

Figure 6-16: Detail WW-16 Non Rigid Sanitary Sewer Pipe Bedding and Backfill Outside of Pavement

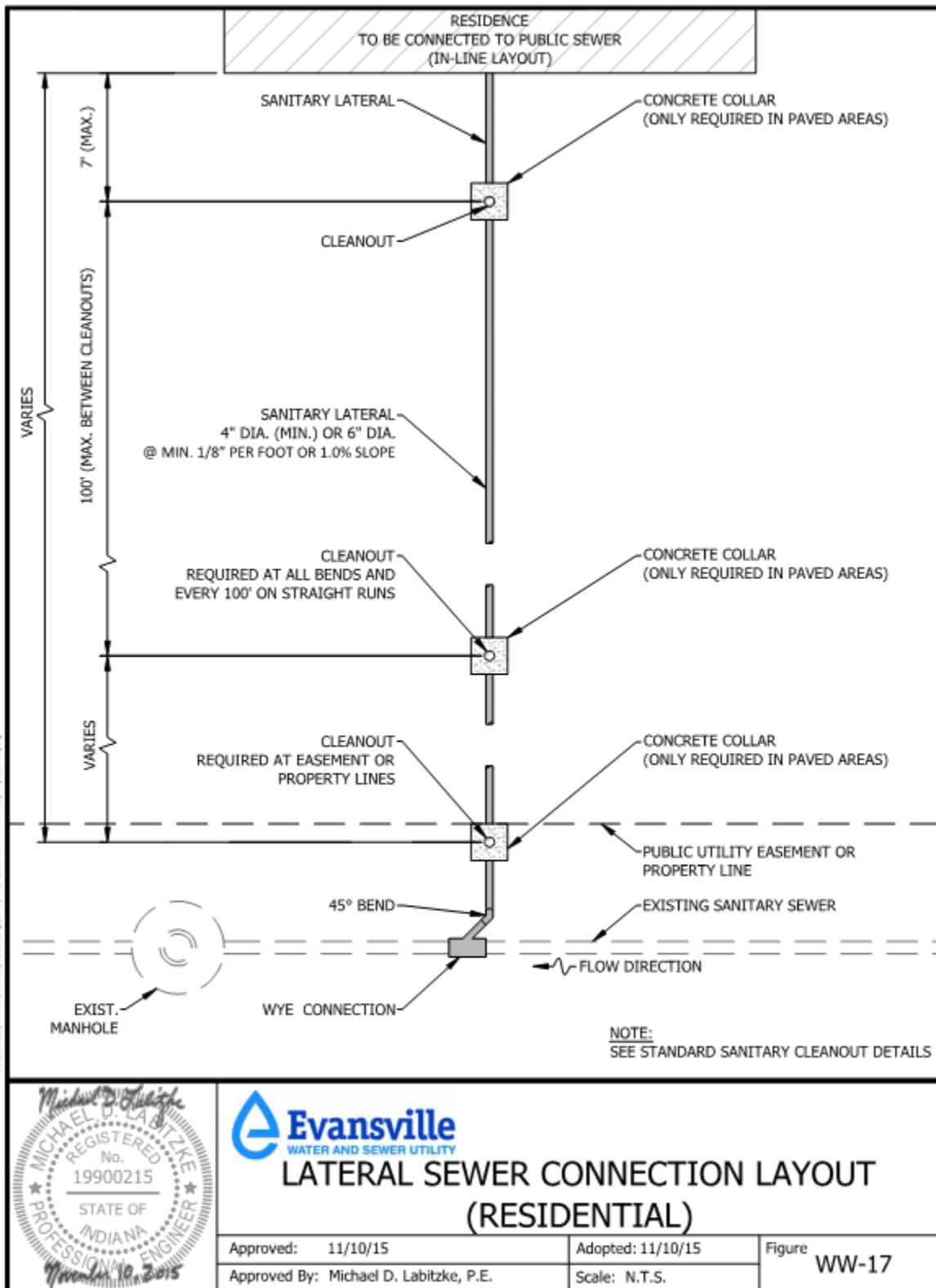

Figure 6-17: Detail WW-17 Lateral Sewer Connection Layout (Residential)

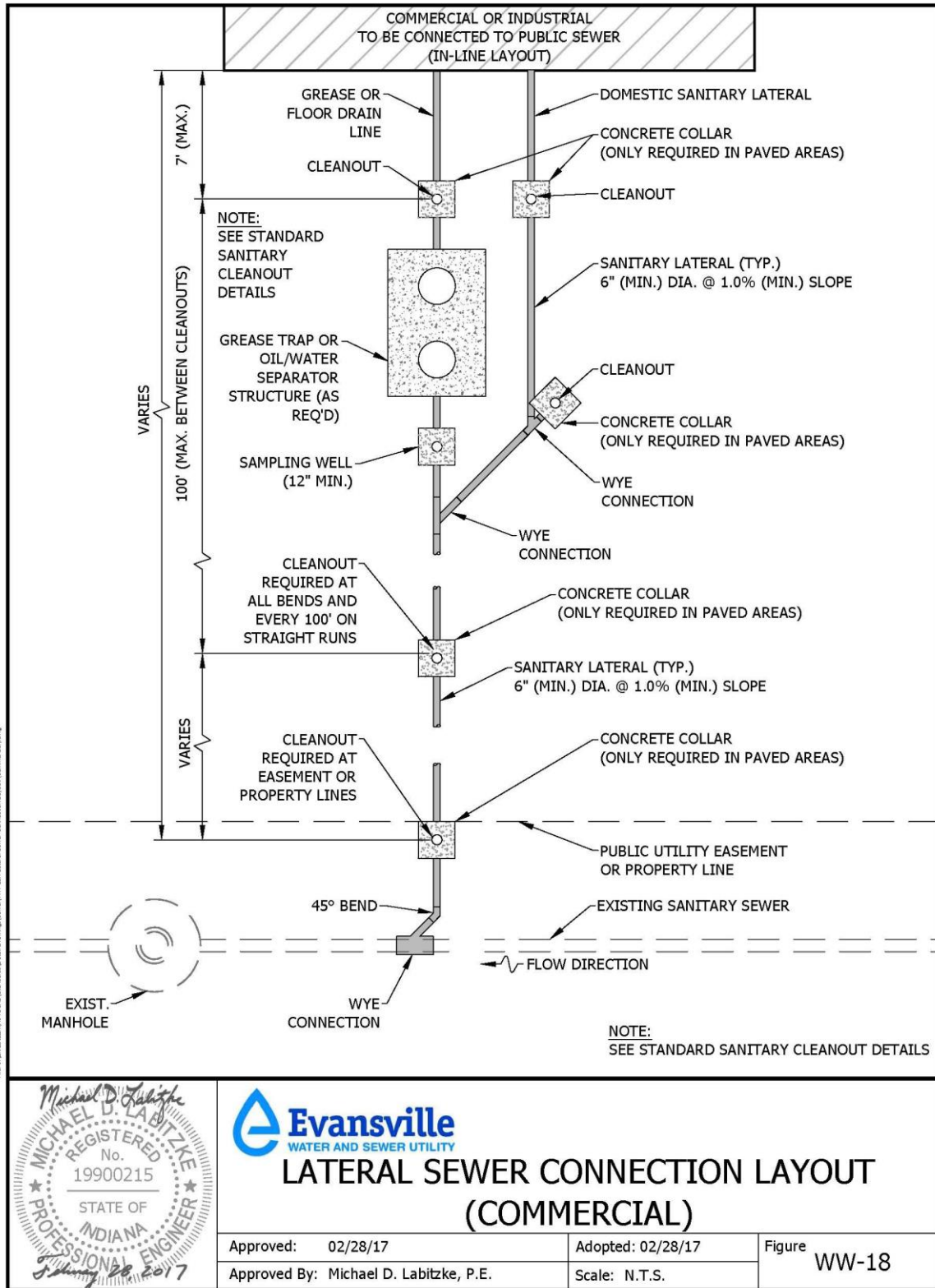

Figure 6-18: Detail WW-18 Lateral Sewer Connection Layout (Commercial)

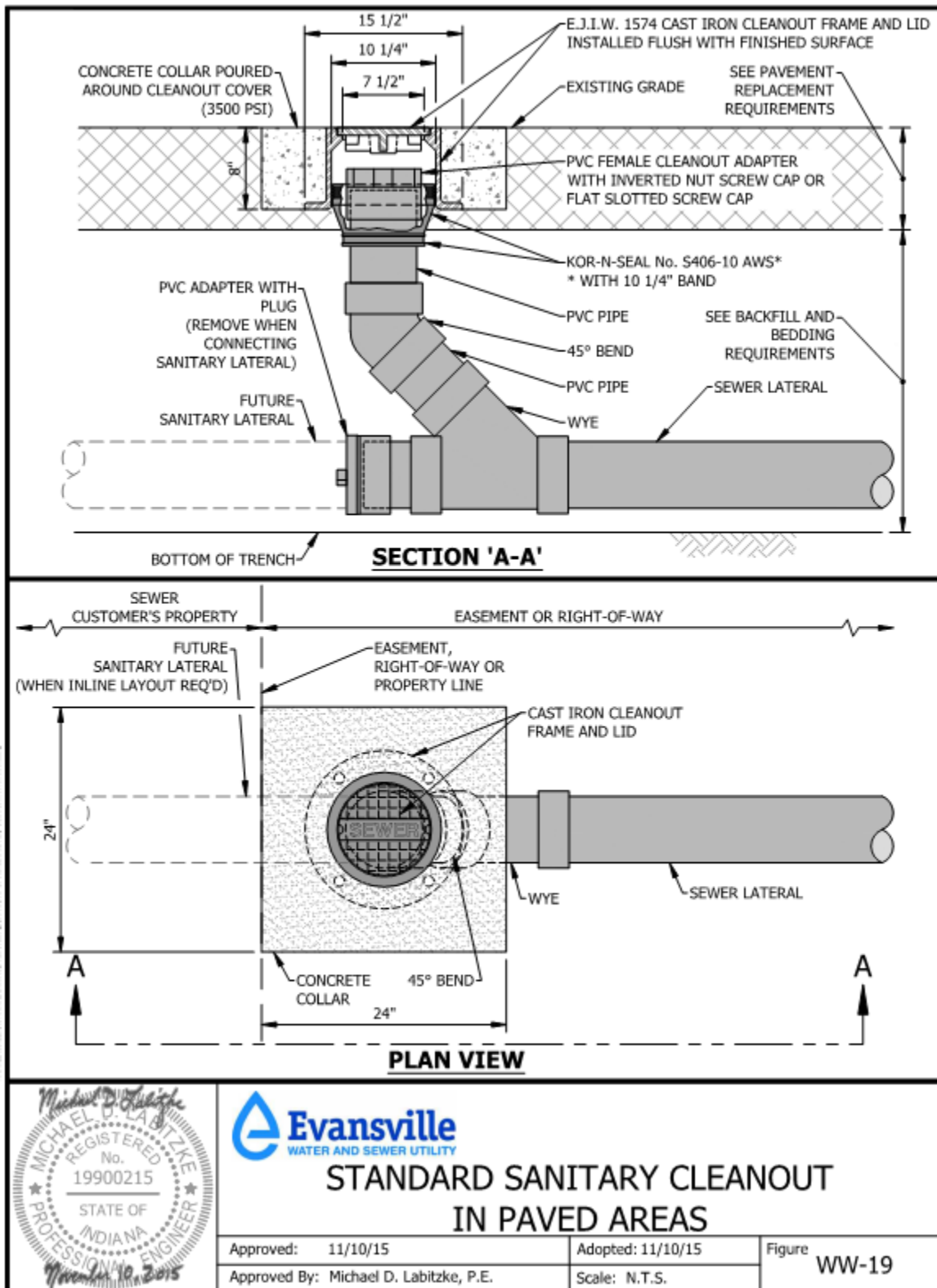

Figure 6-19: Detail WW-19 Standard Sanitary Cleanout in Paved Areas

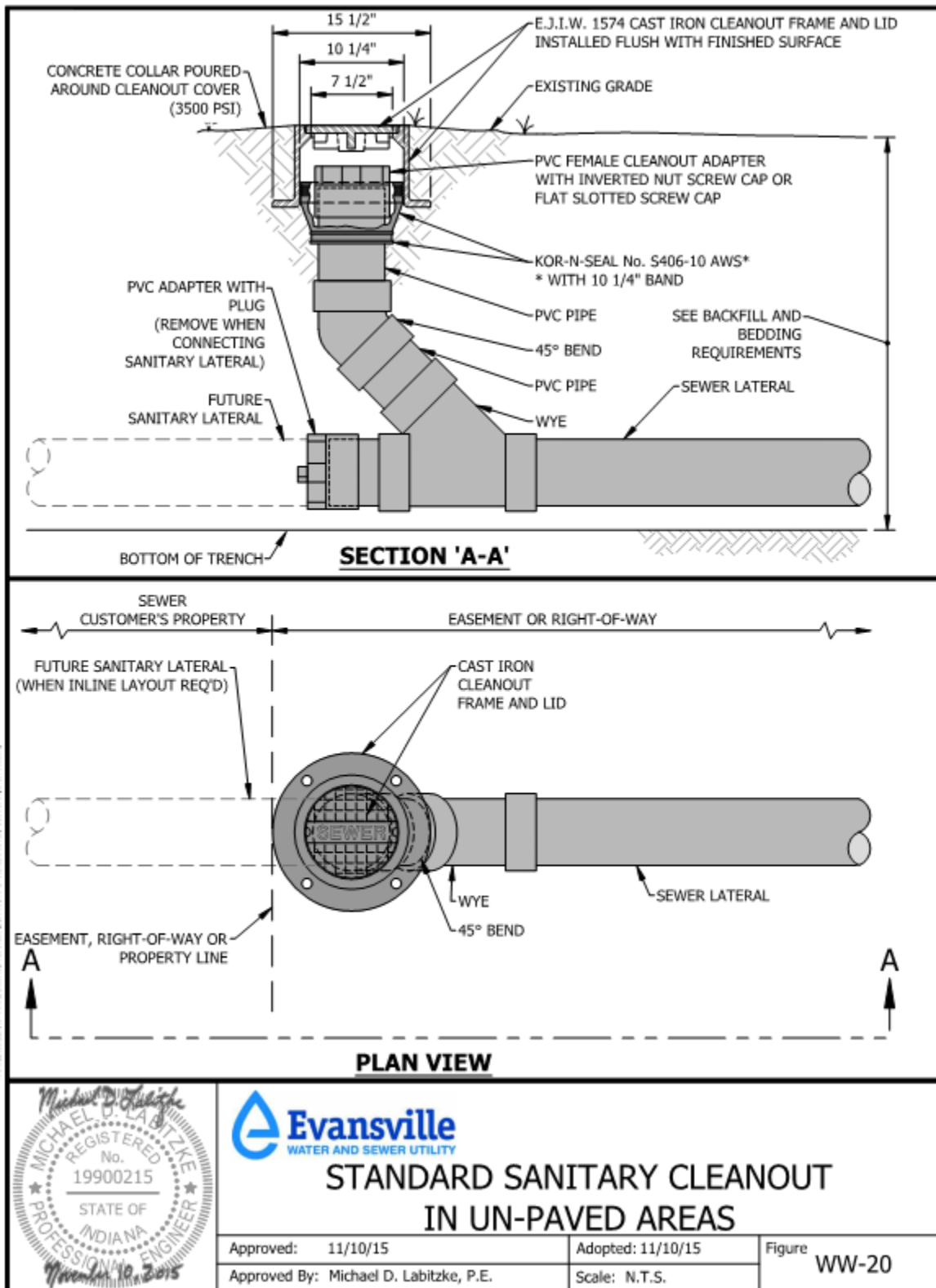

Figure 6-20: Detail WW-20 Standard Sanitary Cleanout in Unpaved Areas

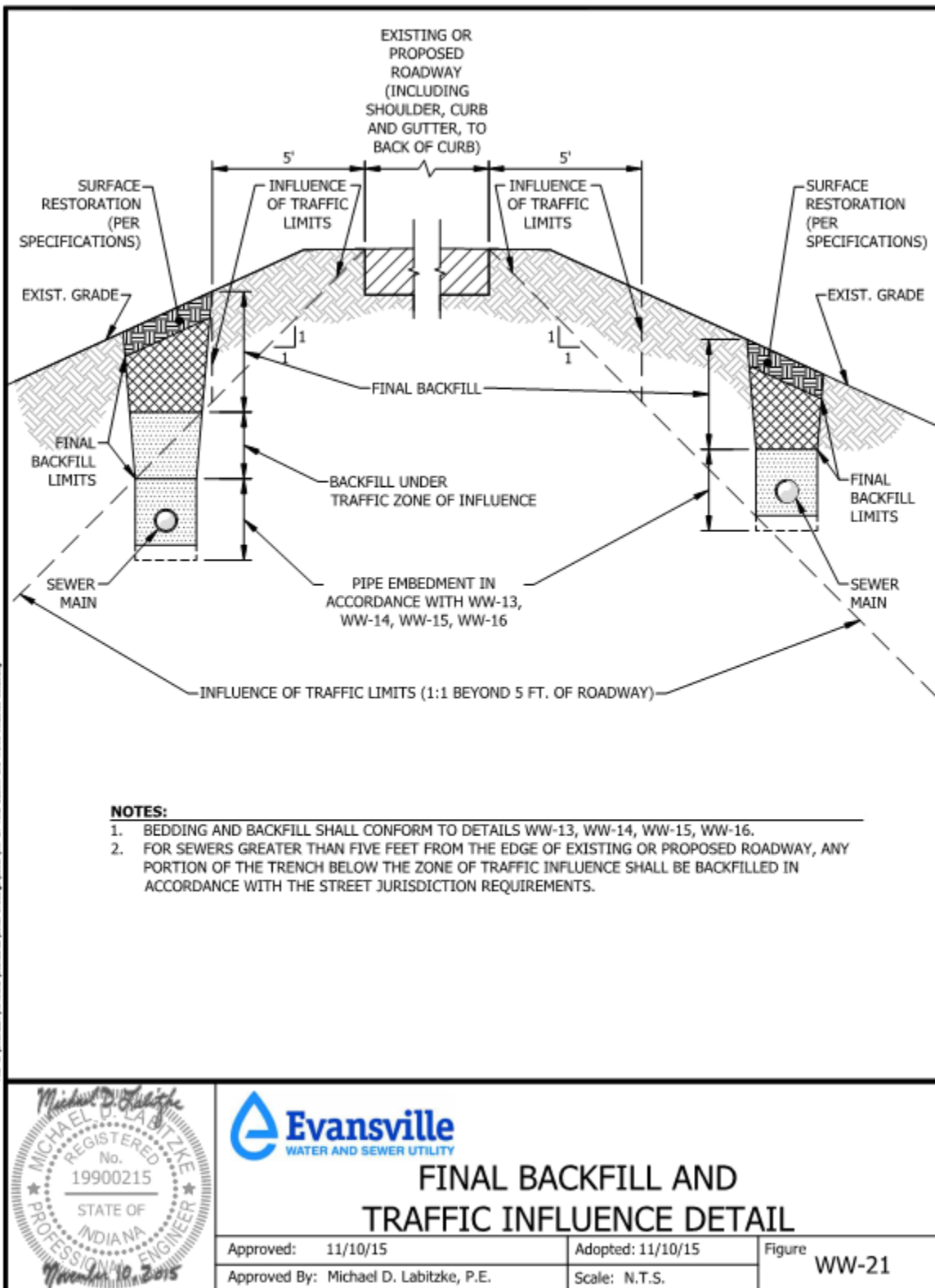

Figure 6-21: Detail WW-21 Final Backfill and Traffic Influence Detail

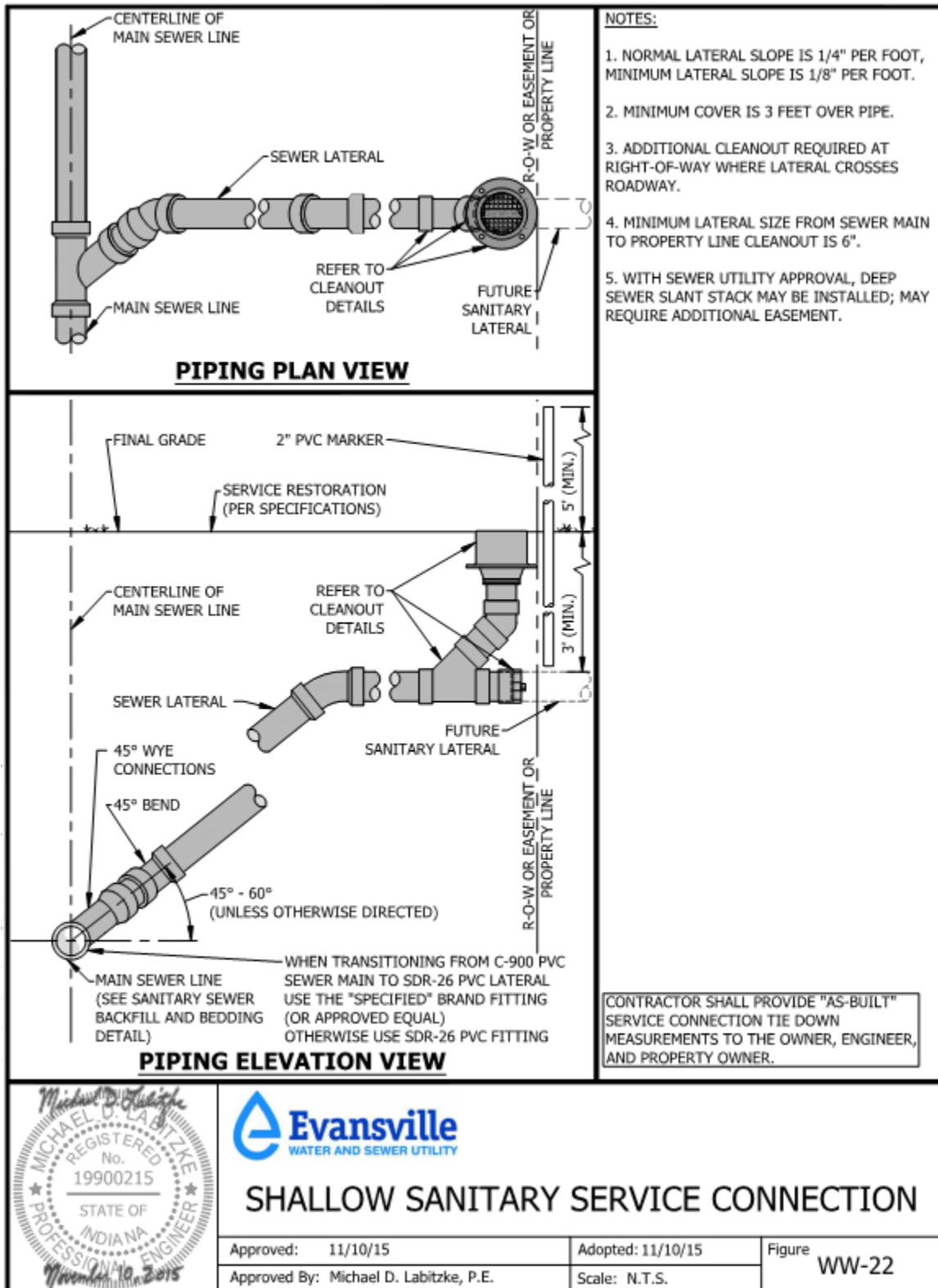

Figure 6-22: Detail WW-22 Shallow Sanitary Service Connection

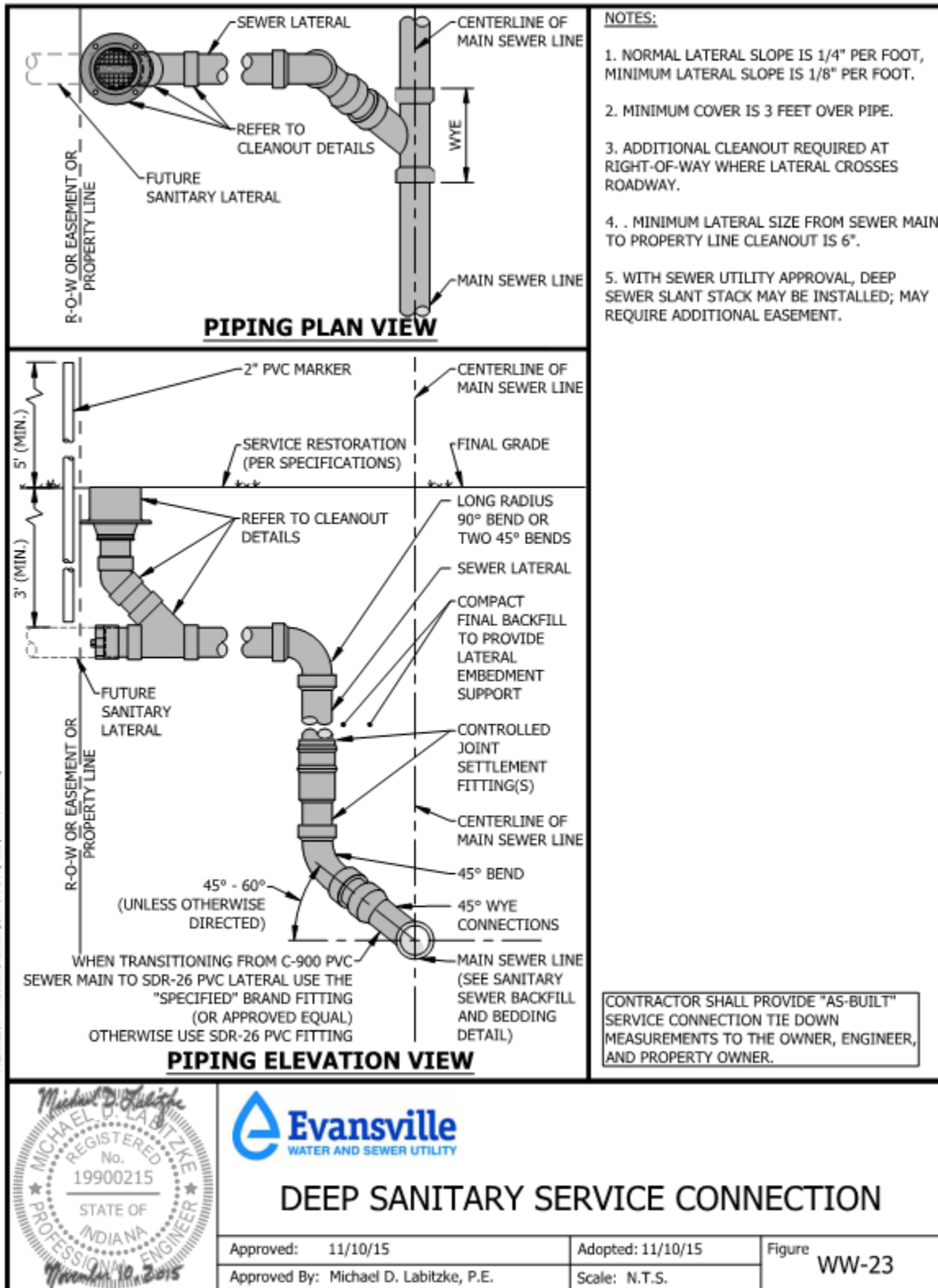

Figure 6-23: Detail WW-23 Deep Sanitary Service Connection

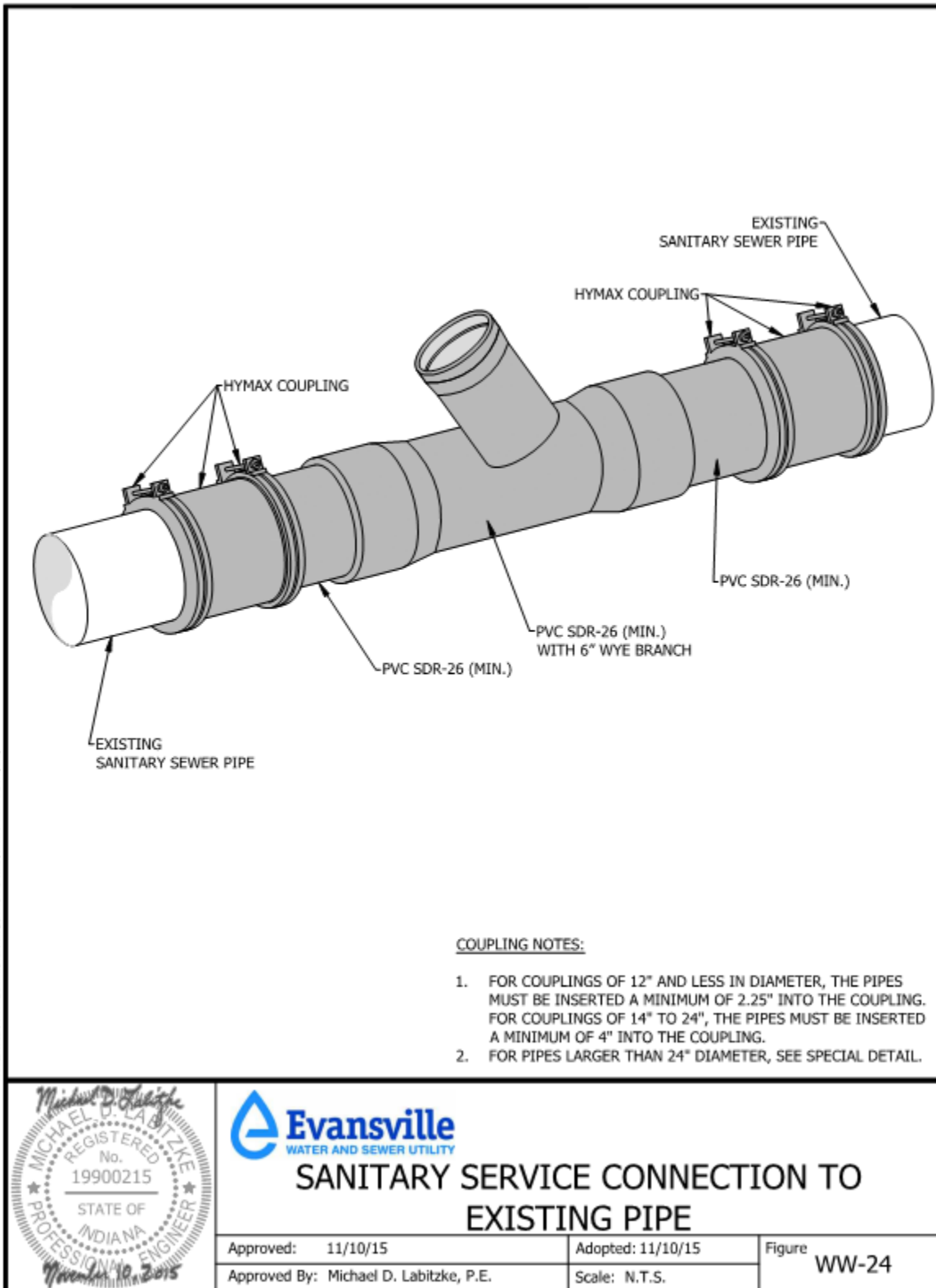

Figure 6-24: Detail WW-24 Sanitary Service Connection to Existing Pipe

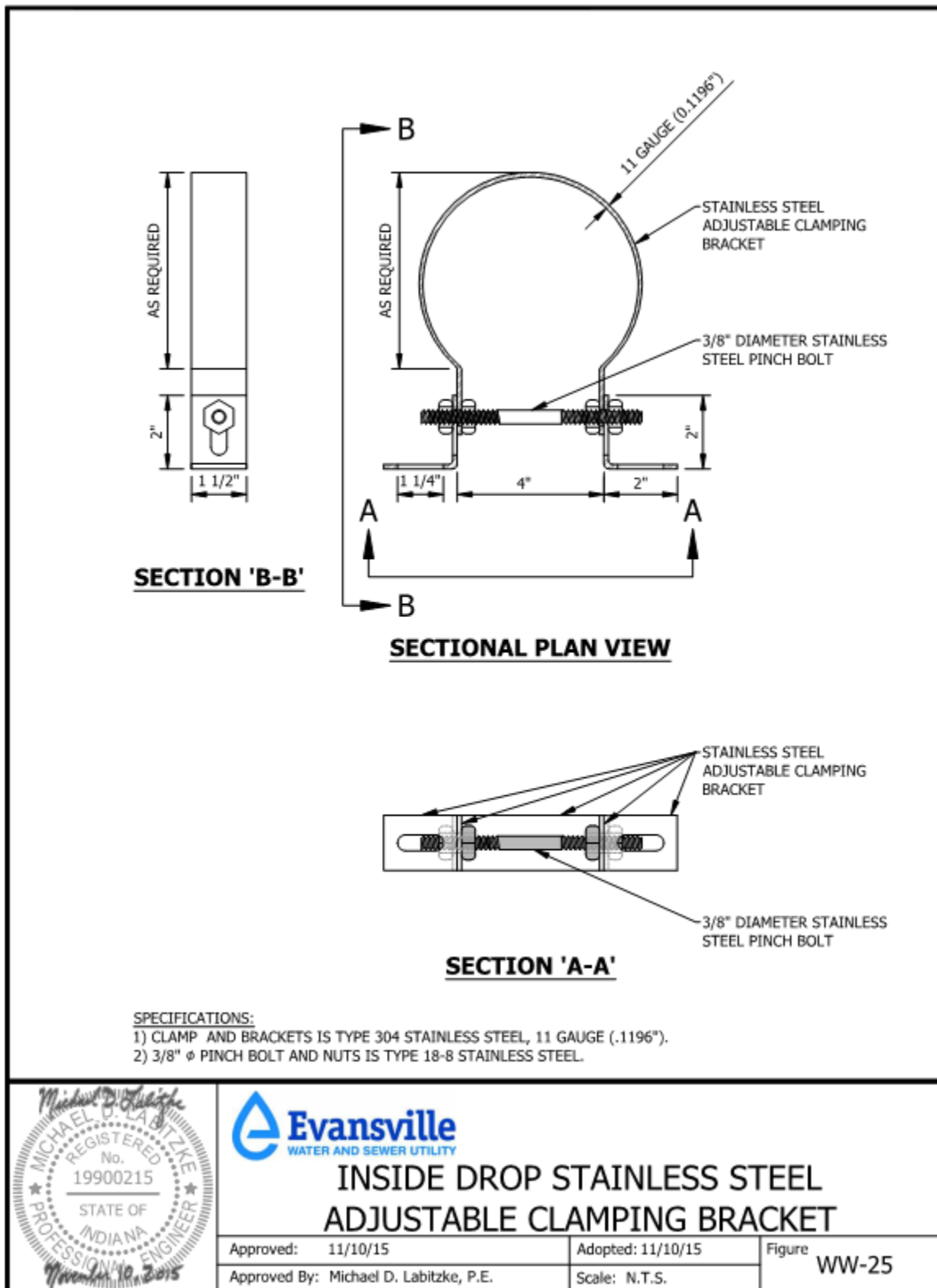
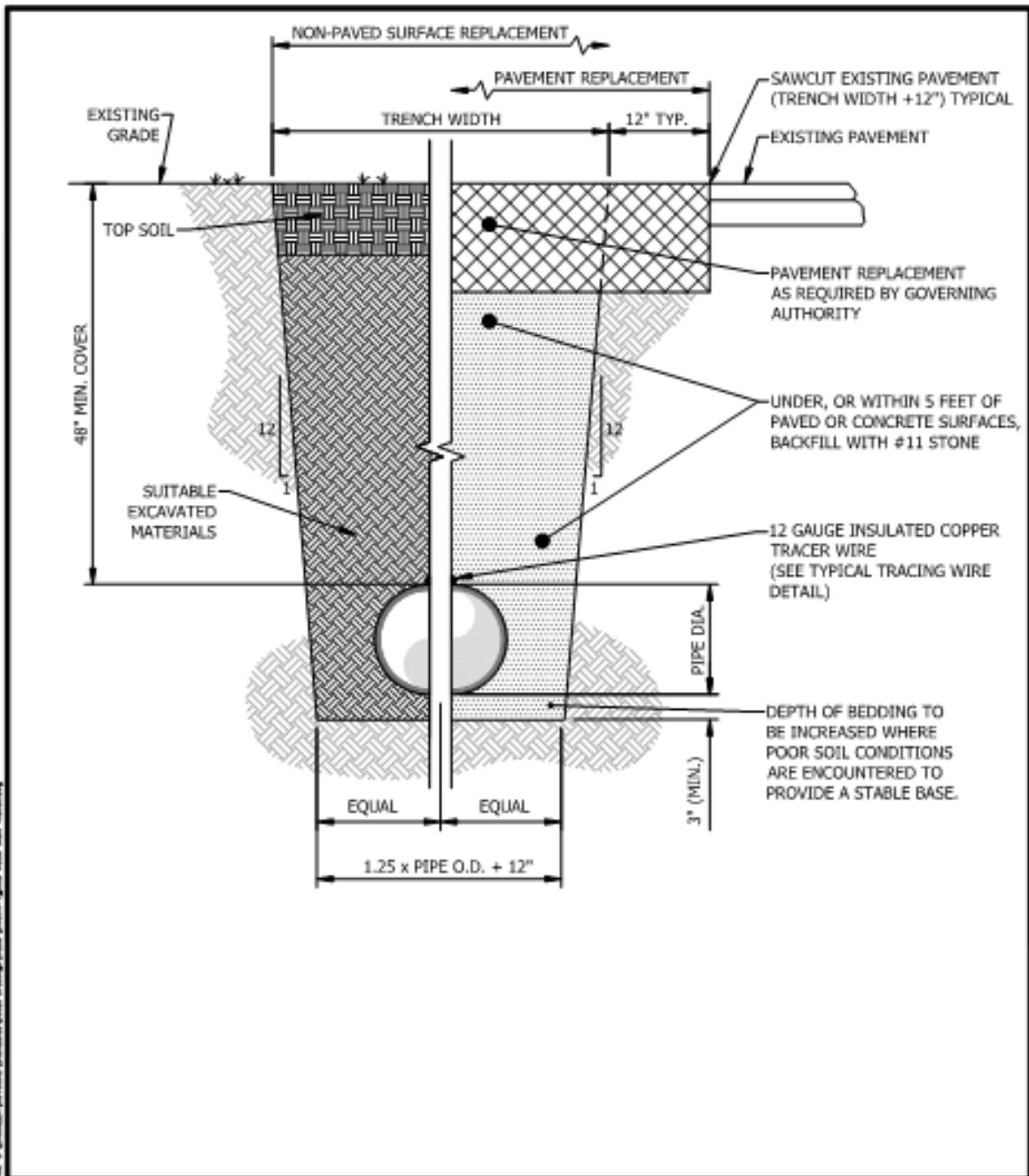

Figure 6-25: Detail WW-25 Inside Drop Stainless Steel Adjustable Clamping Bracket



			<h3>TYPICAL WATER MAIN TRENCH</h3>	
	Approved: 02/28/17 Approved By: Michael D. Labitzke, P.E.	Adopted: 02/28/17 Scale: N.T.S.	Figure DW01	

Figure 6-26: Detail DW-01 Typical Water Main Trench

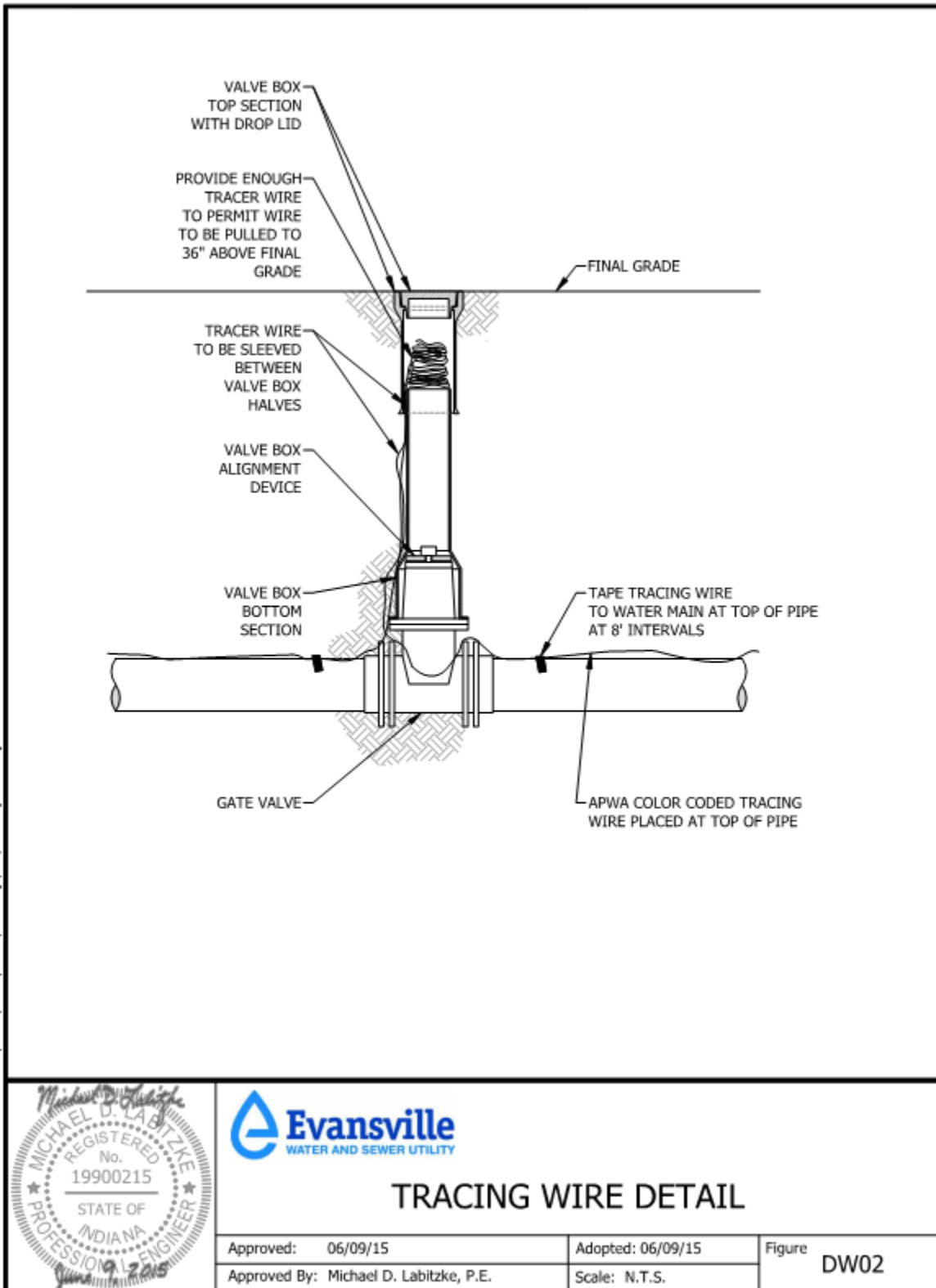

Figure 6-27: Detail DW-02 Tracing Wire Detail

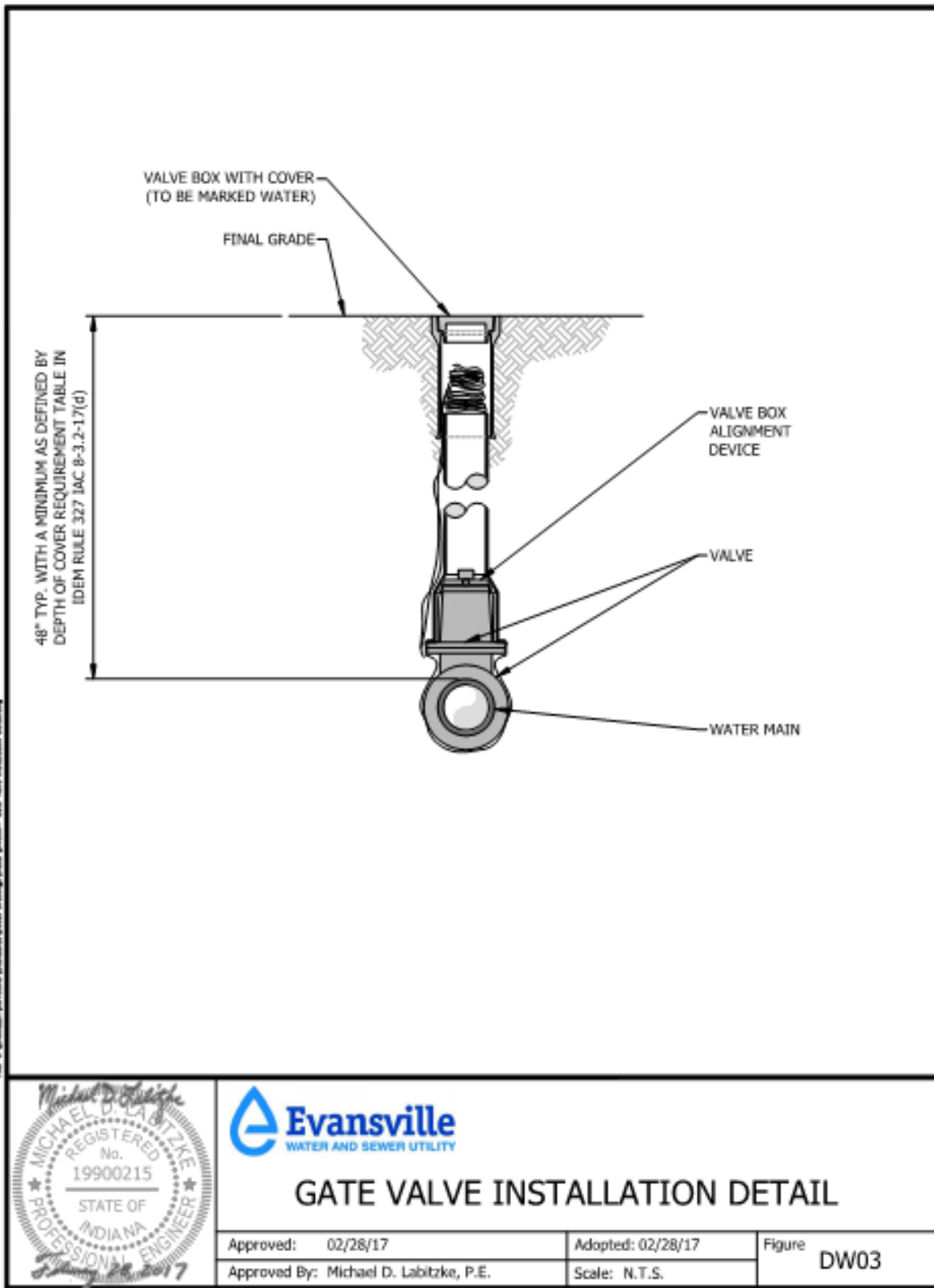
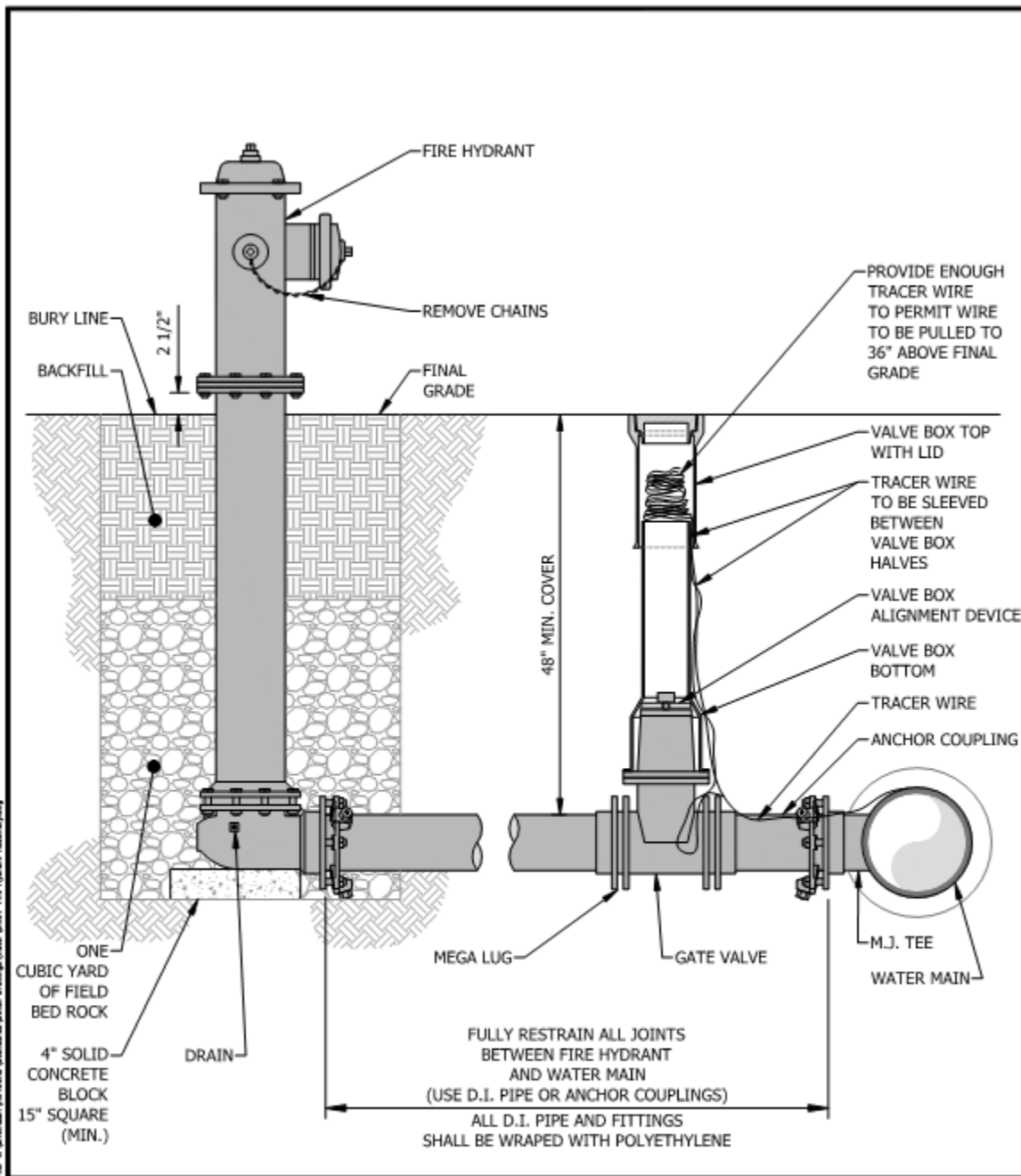
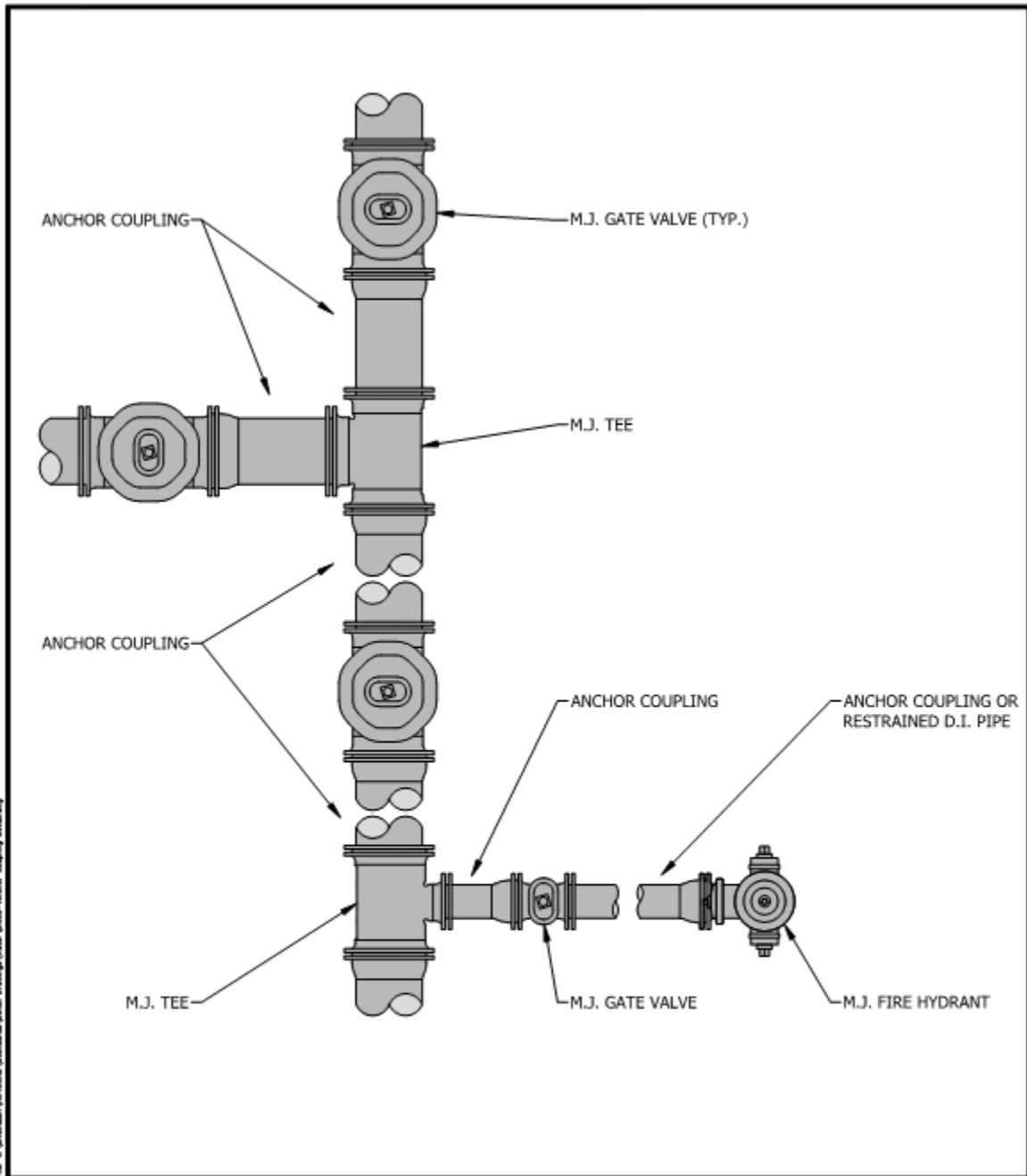

Figure 6-28: Detail DW-03 Gate Valve Installation Detail



			<h3>FIRE HYDRANT ASSEMBLY</h3>	
	Approved: 06/09/15 Approved By: Michael D. Labitzke, P.E.	Adopted: 06/09/15 Scale: N.T.S.	Figure DW04	

Figure 6-29: Detail DW-04 Fire Hydrant Assembly



			<h3>ANCHOR COUPLING DETAIL</h3>	
	Approved: 06/09/15 Approved By: Michael D. Labitzke, P.E.	Adopted: 06/09/15 Scale: N.T.S.	Figure DW05	

Figure 6-30: Detail DW-05 Anchor Coupling Detail

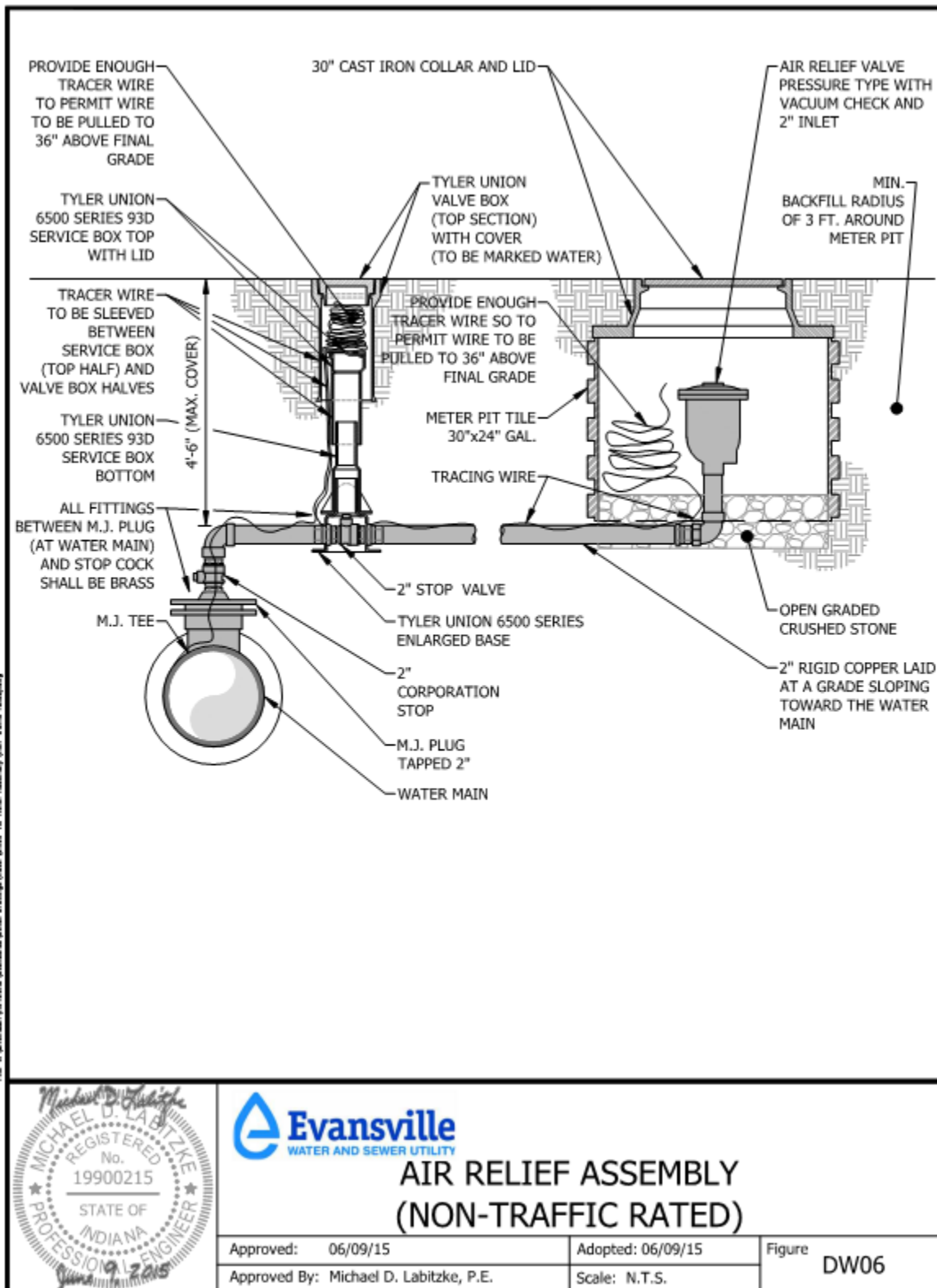
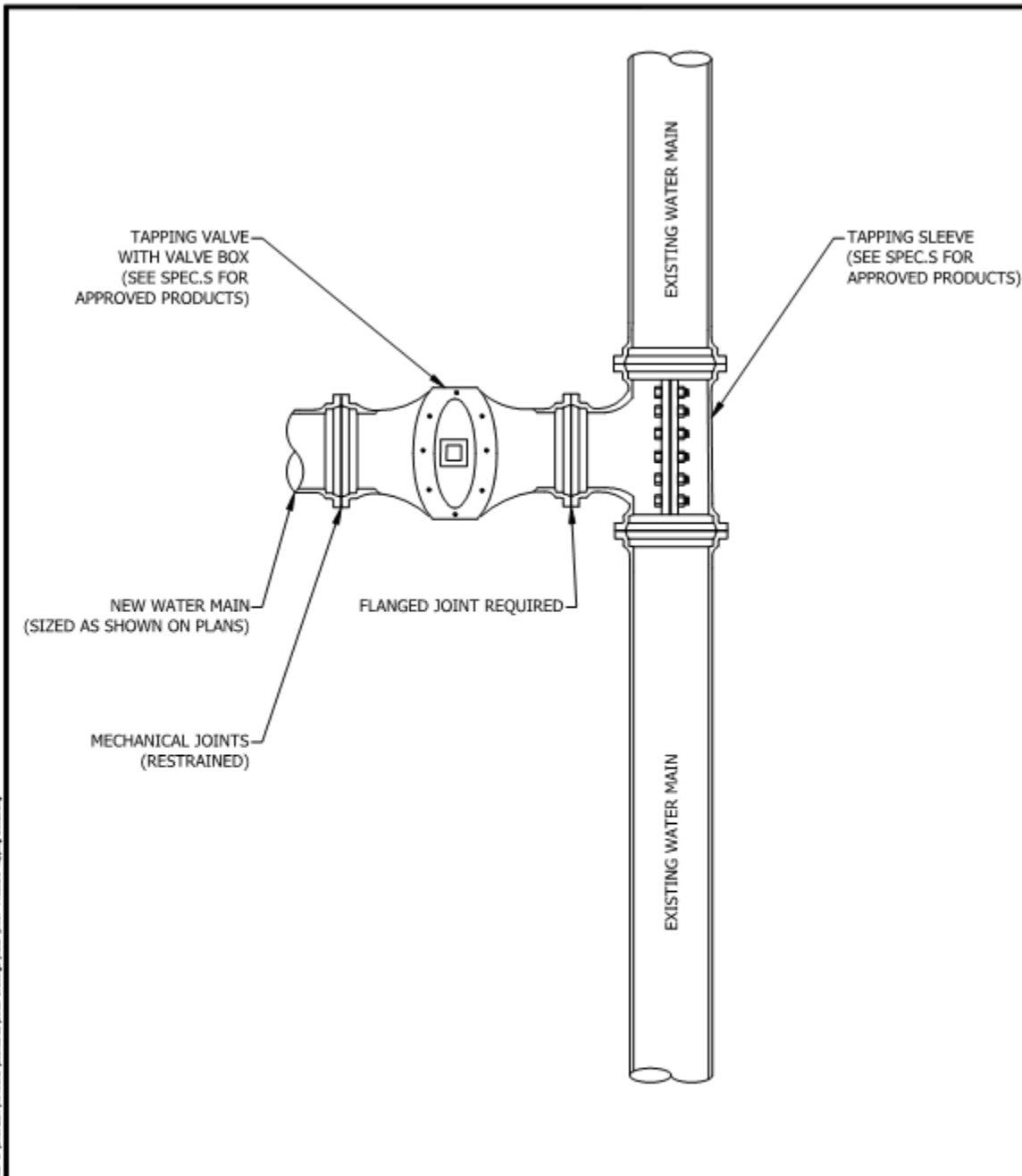

Figure 6-31: Detail DW-06 Air Relief Assembly (Non-Traffic Rated)



			<h3>PRESSURE TAPPING DETAIL</h3>	
	Approved: 06/09/15 Approved By: Michael D. Labitzke, P.E.	Adopted: 06/09/15 Scale: N.T.S.	Figure DW07	

Figure 6-32: Detail DW-07 Pressure Tapping Detail

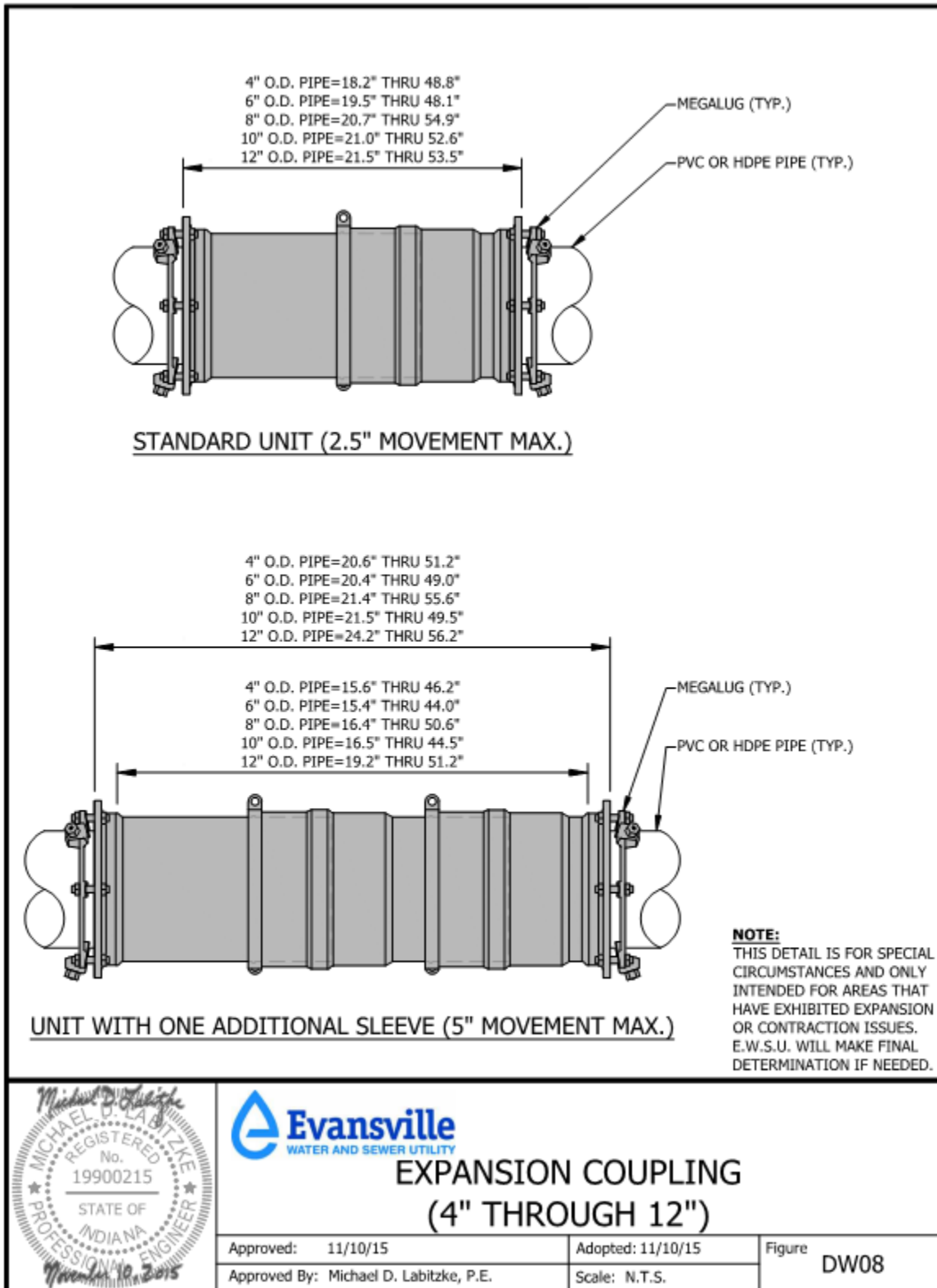

Figure 6-33: Detail DW-08 Expansion Coupling (4" Through 12")

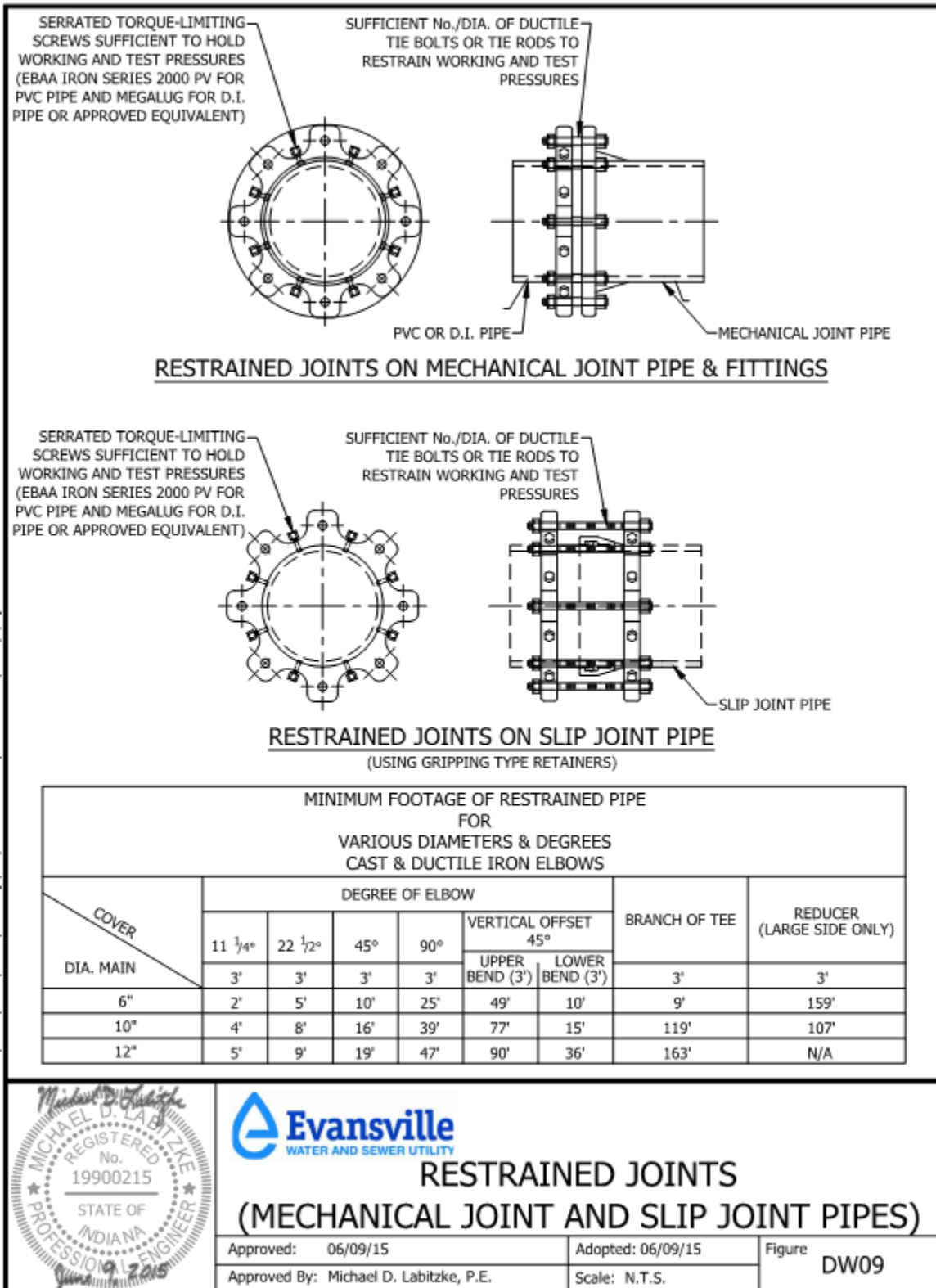

Figure 6-34: Detail DW-09 Restrained Joints (Mechanical Joint and Slip Joint Pipes)

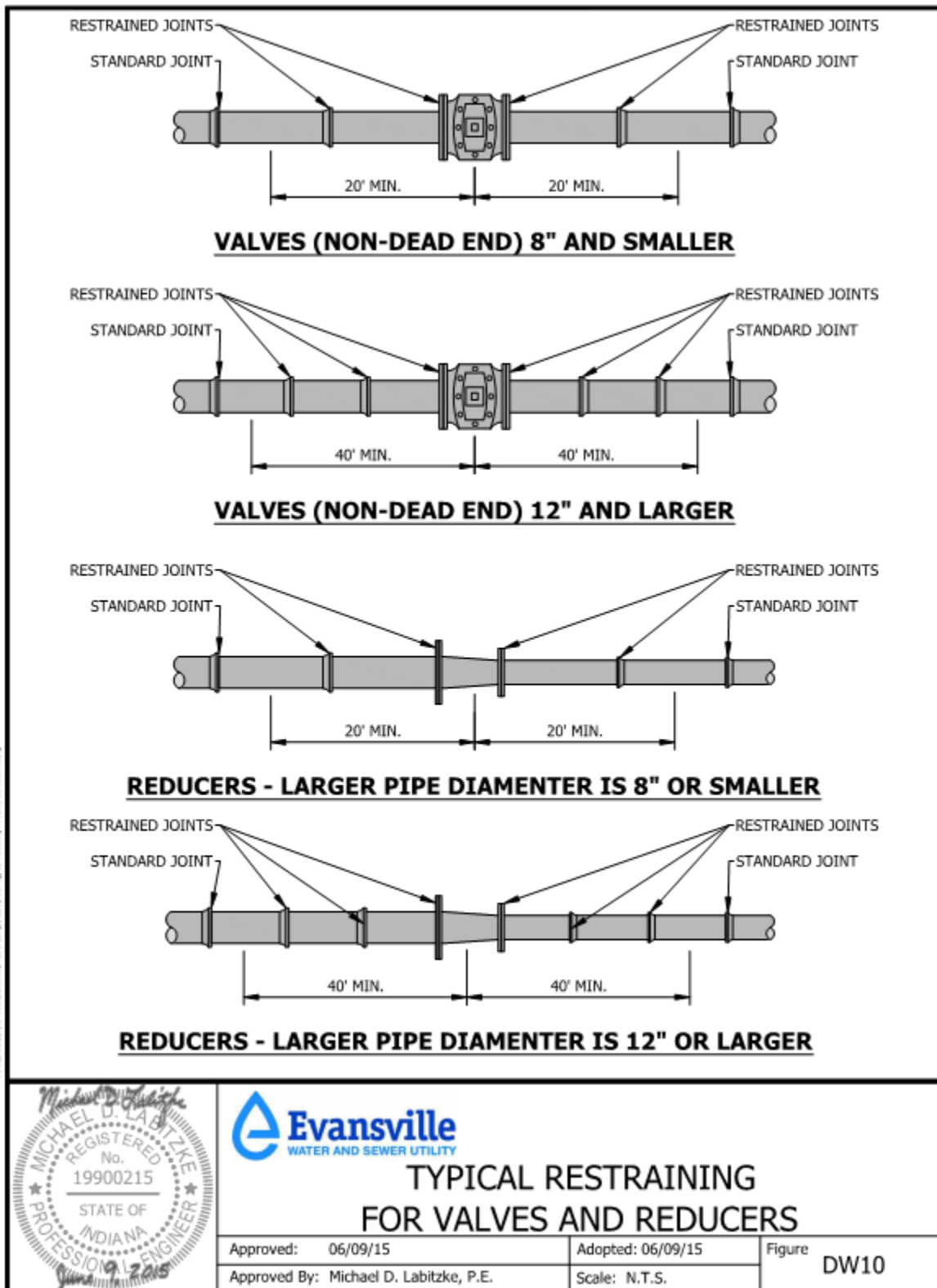

Figure 6-35: Detail DW-10 Typical Restraining For Valves and Reducers

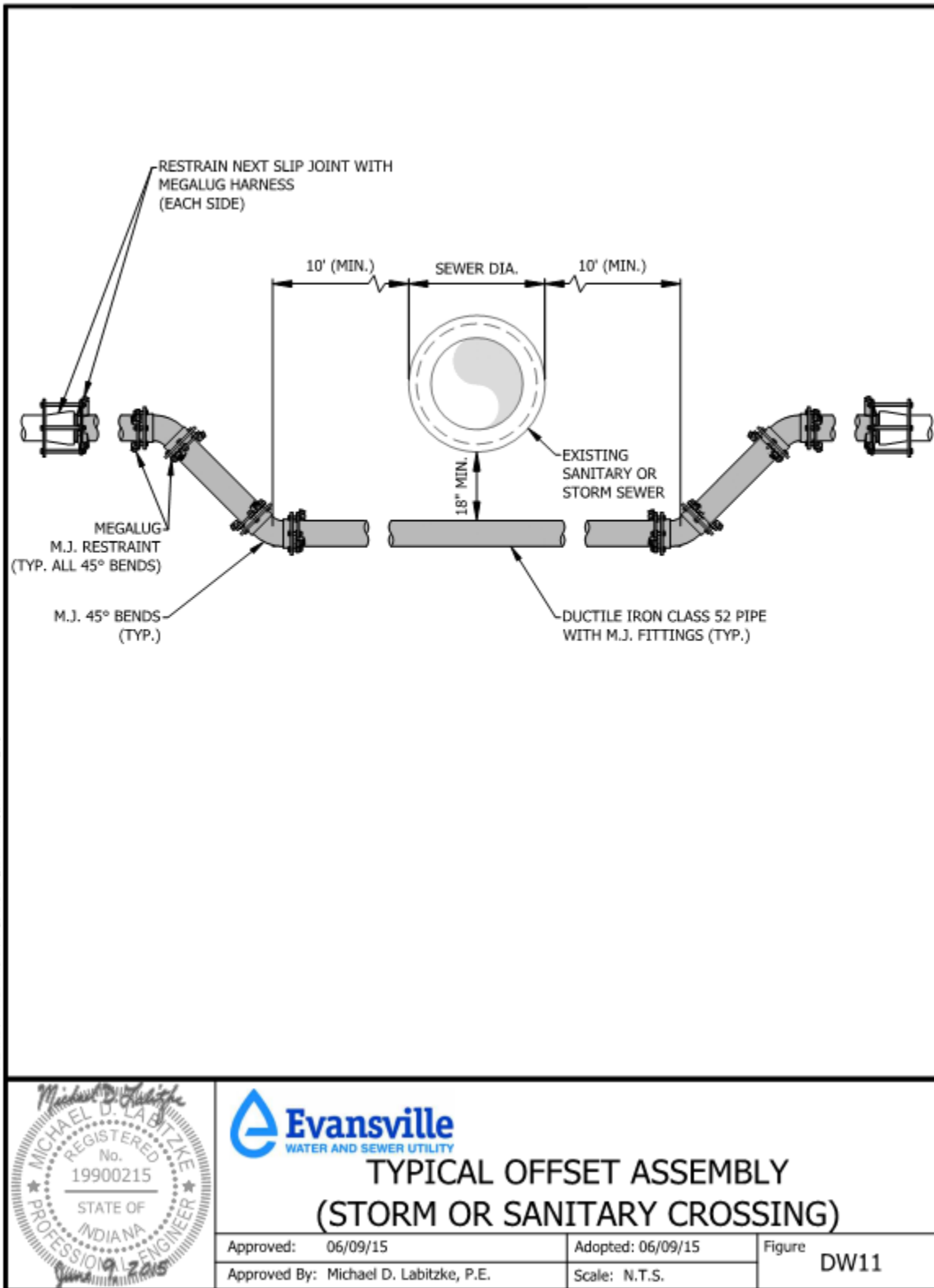

Figure 6-36: Detail DW-11 Typical Offset Assembly (Storm or Sanitary Crossing)

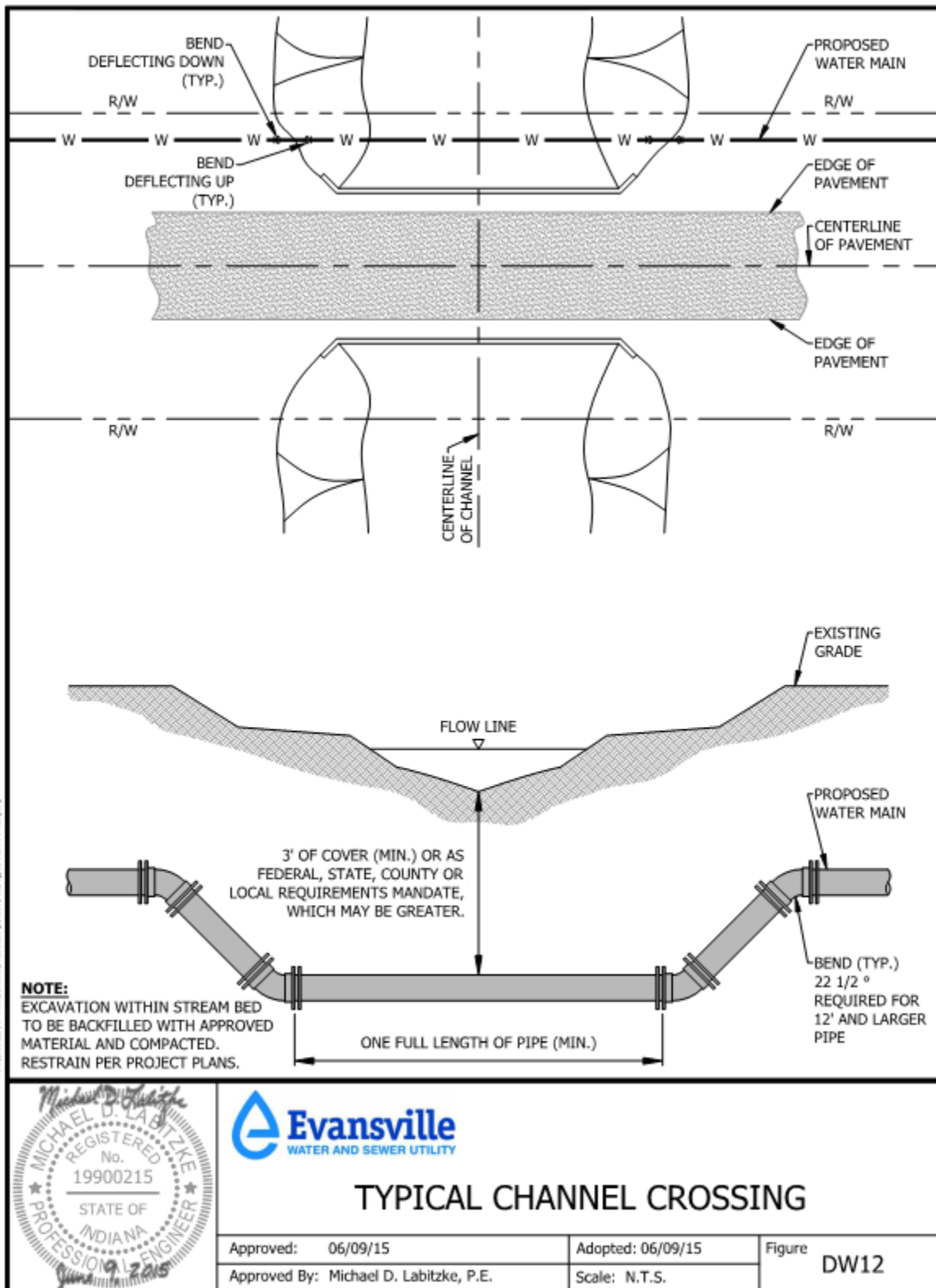

Figure 6-37: Detail DW-12 Typical Channel Crossing

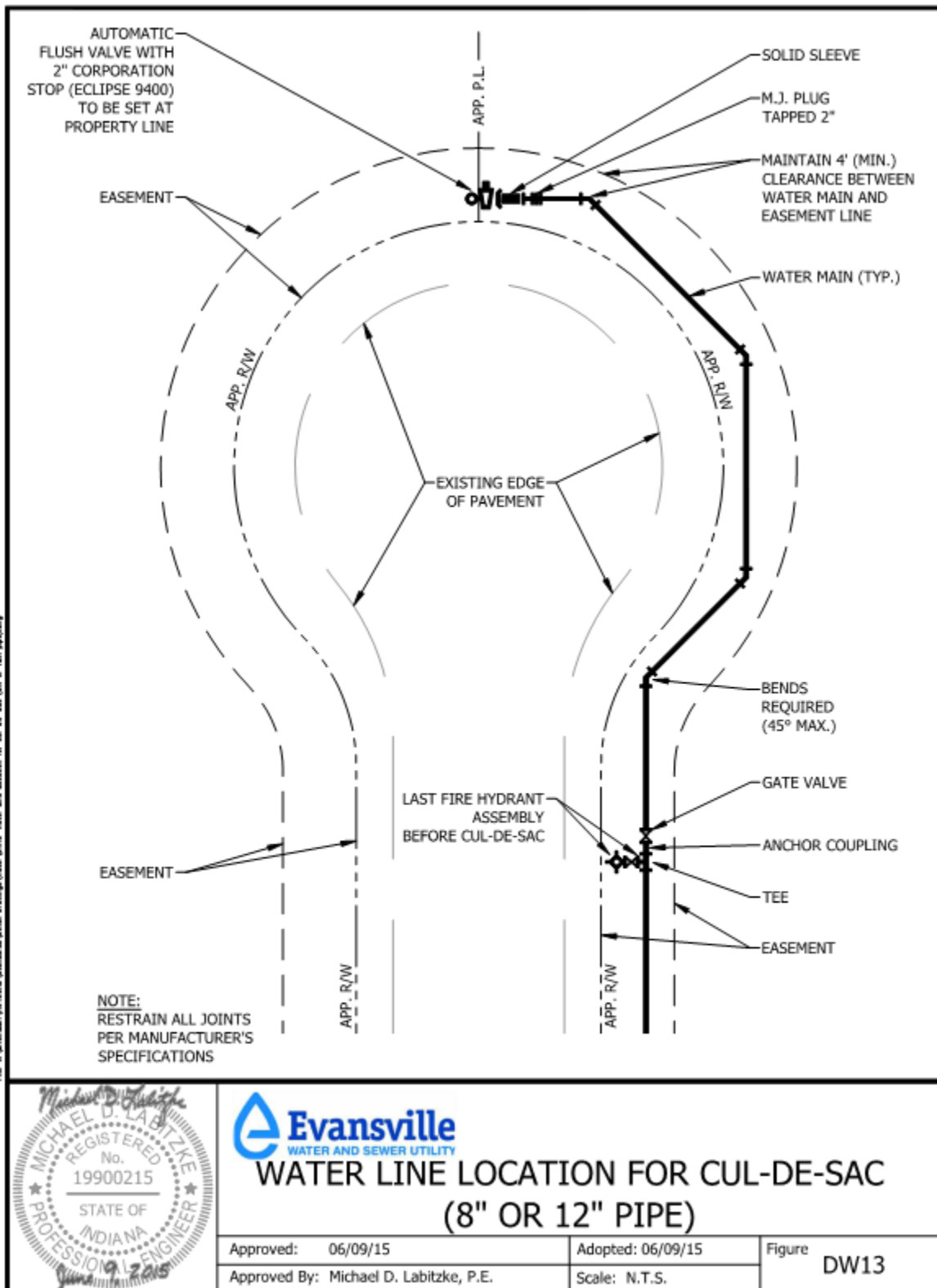

Figure 6-38: Detail DW-13 Water Line Location for Cul-De-Sac (8" or 12" Pipe)

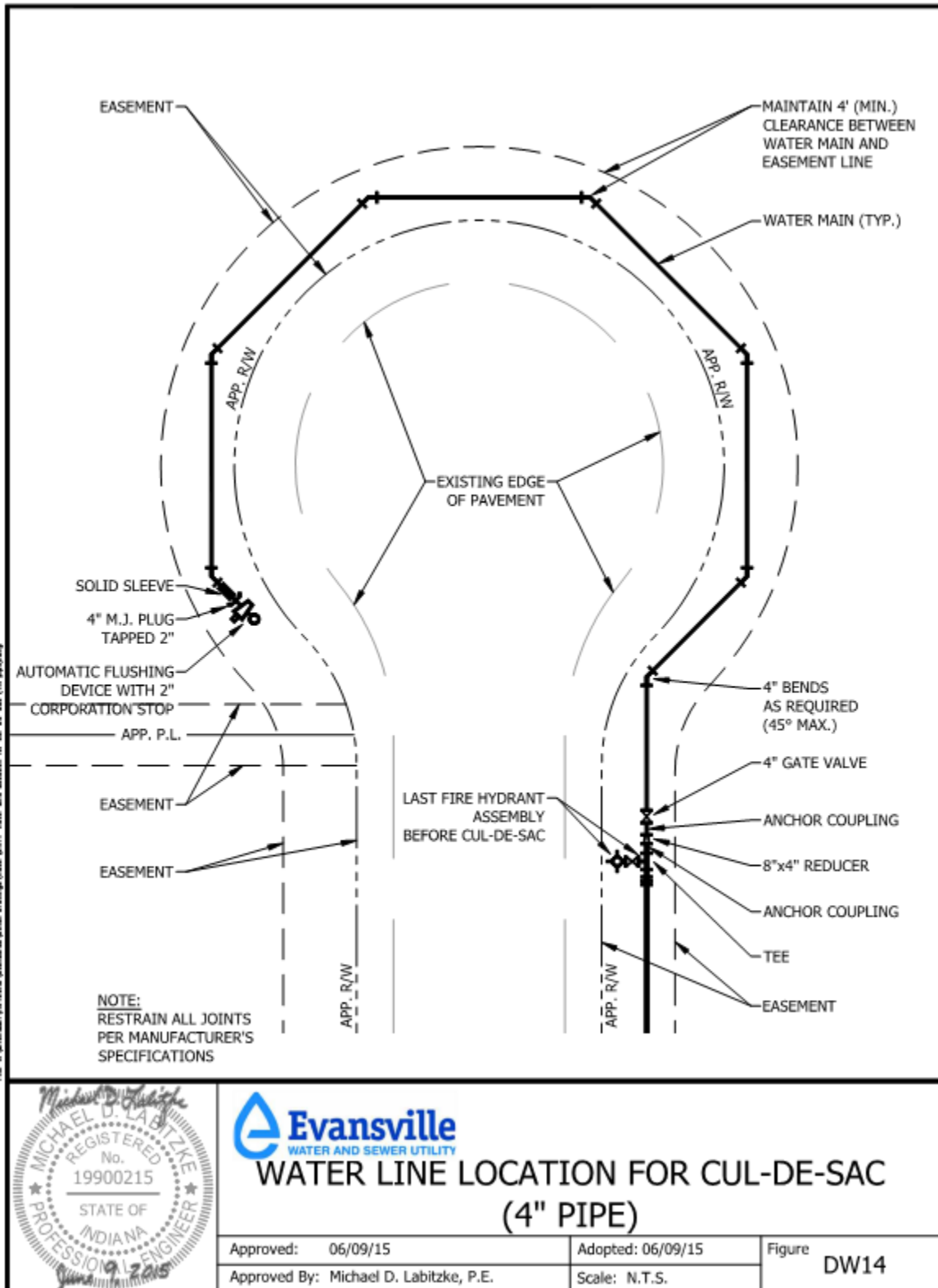

Figure 6-39: Detail DW-14 Water Line Location for Cul-De-Sac (4" Pipe)

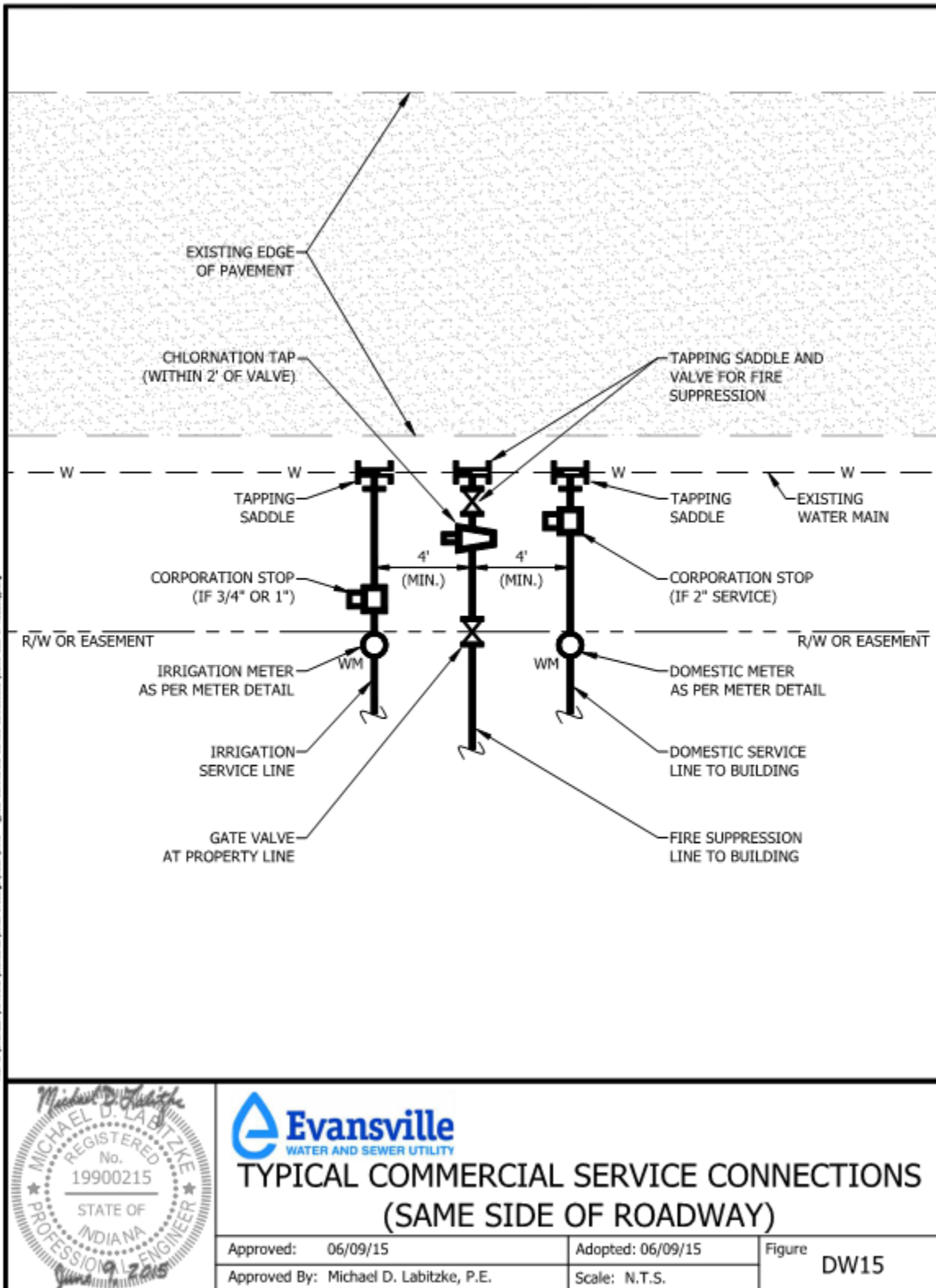

Figure 6-40: Detail DW-15 Typical Commercial Service Connections (Same Side of Roadway)

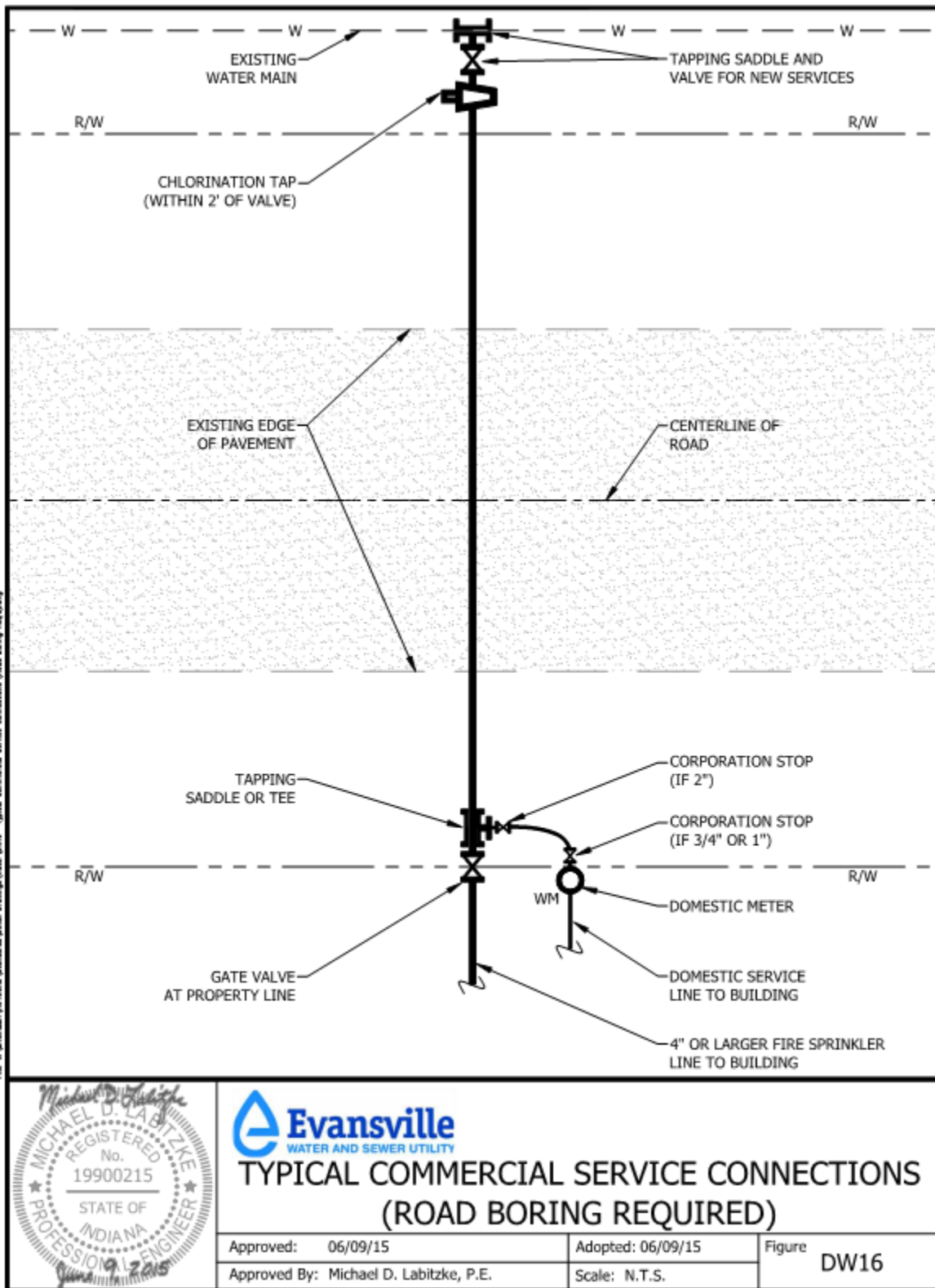
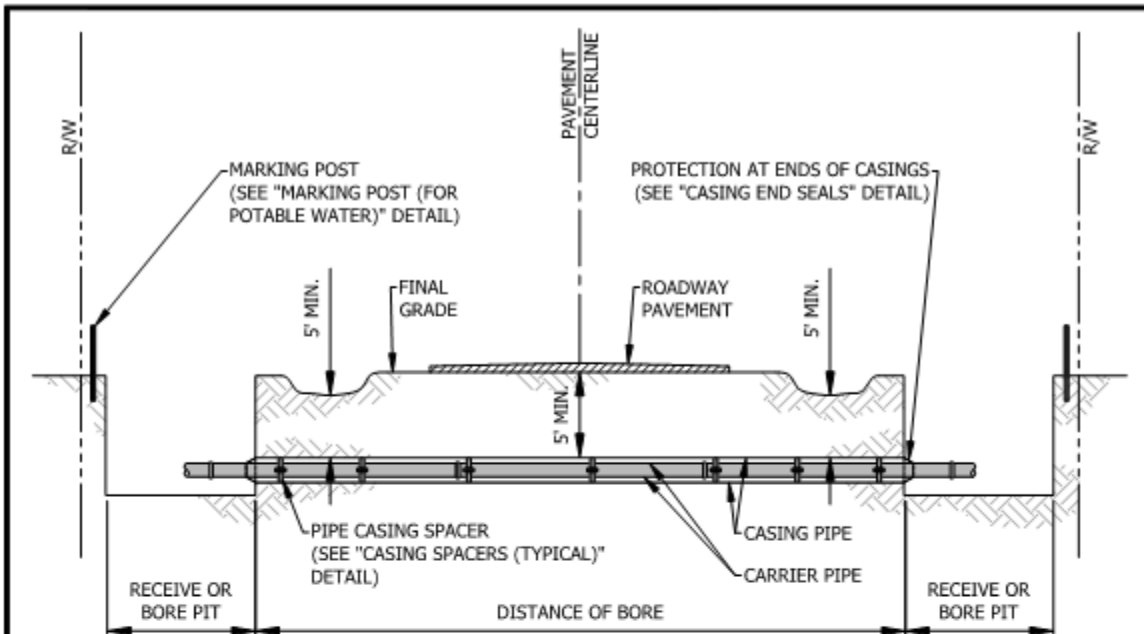

Figure 6-41: Detail DW-16 Typical Commercial Service Connection (Road Boring Required)



WELDING:

STEEL CASING SECTIONS SHALL BE CONNECTED BY WELDING. WELD SHALL CONFORM TO AWWA C206.

NOTE:

1. ALL PIPE JOINTS WITHIN THE CASING ARE TO BE RESTRAINED.
2. TRACING WIRE TO BE INSTALLED THROUGH ALL CASED BORINGS AND CONNECTED TO MARKING POSTS.
3. STEEL PIPE CASING SHALL CONFORM TO THE REQUIREMENTS OF ASTM A283, GRADE B, C, OR D. ALL JOINTS SHALL BE WELDED. ALL WELDING SHALL BE PERFORMED IN ACCORDANCE WITH AWWA C206, "AWWA STANDARD FOR FIELD WELDING OF STEEL WATER PIPE". COATING FOR STEEL CASING IS NOT REQUIRED.
4. STEEL PIPE CASING SHALL BE INSTALLED SYMMETRICAL ABOUT WATER MAIN CENTERLINE (TYP). PIPE CASING SHALL BE LAID TRUE TO LINE AND GRADE WITH NO BENDS OR CHANGES IN GRADE FOR THE FULL LENGTH OF THE CASING.



		TYPICAL JACK AND BORE CASING PIPE	
	Approved: 06/09/15 Approved By: Michael D. Labitzke, P.E.	Adopted: 06/09/15 Scale: N.T.S.	Figure DW17

Figure 6-42: Detail DW-17 Typical Jack and Bore Casing Pipe



TYPICAL CASING SPACERS

Approved: 06/09/15	Adopted: 06/09/15	Figure DW18
Approved By: Michael D. Labitzke, P.E.	Scale: N.T.S.	

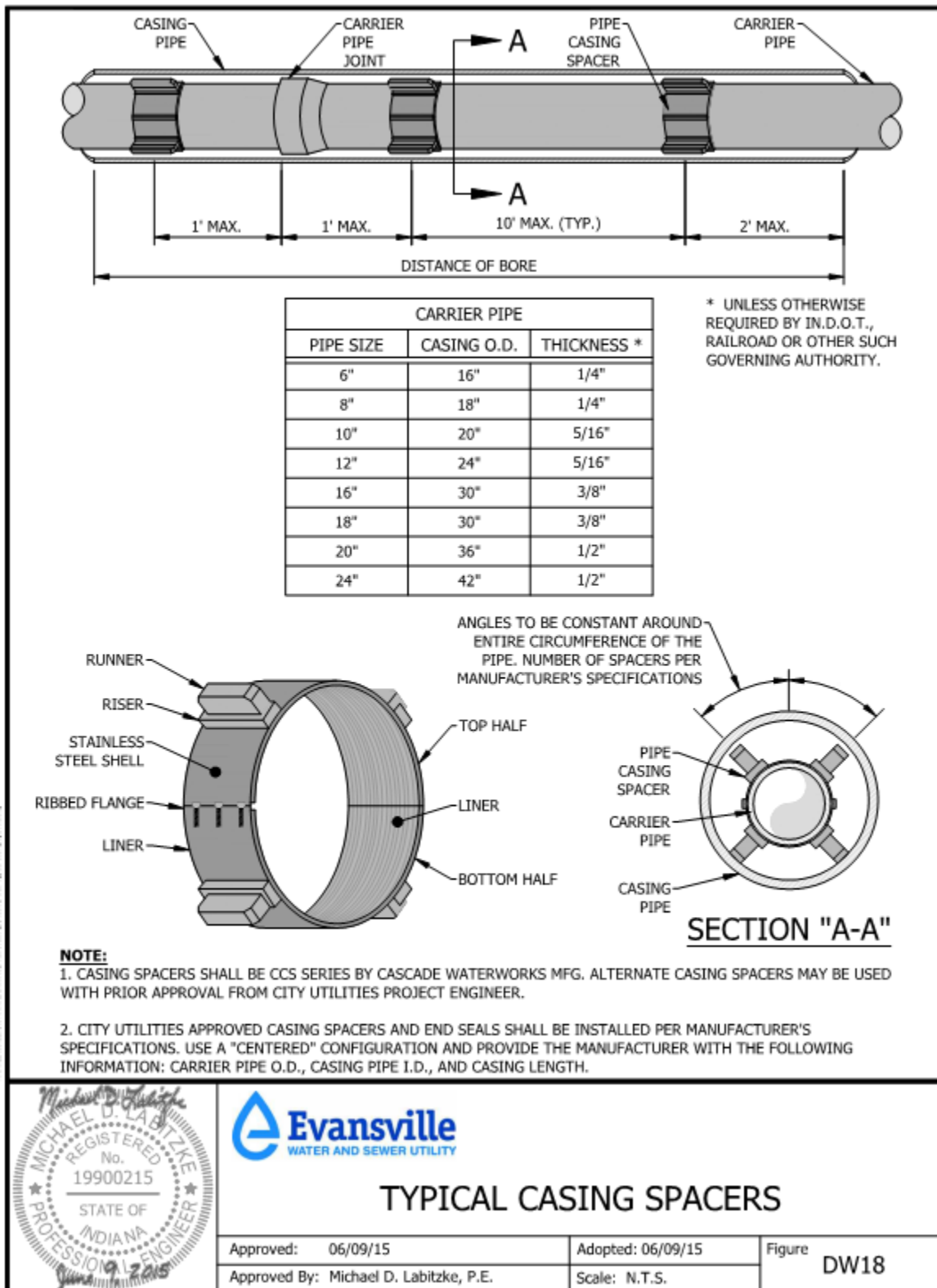
Figure 6-43: Detail DW-18 Typical Casing Spacers

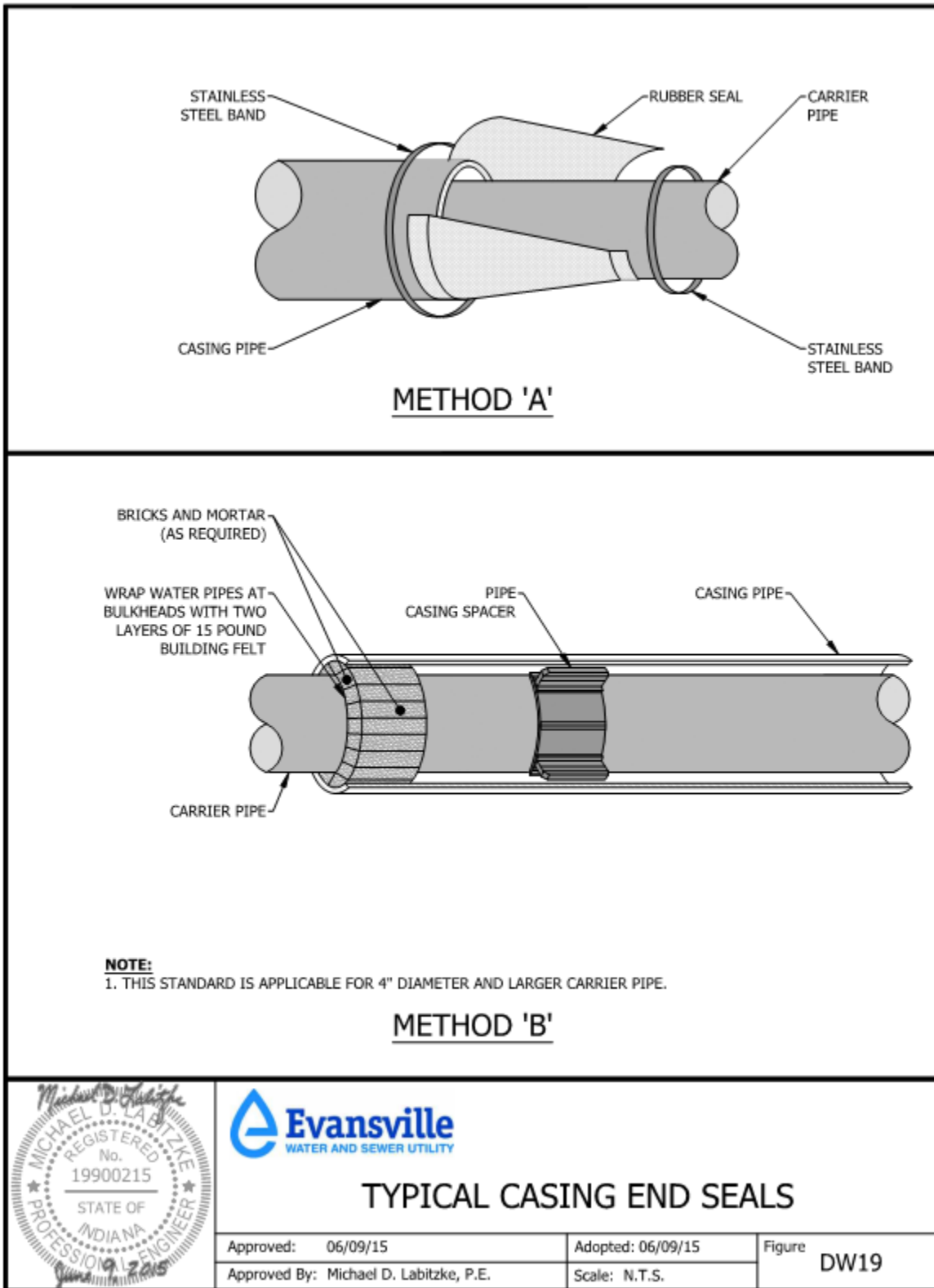

Figure 6-44: Detail DW-19 Typical Casing End Seals

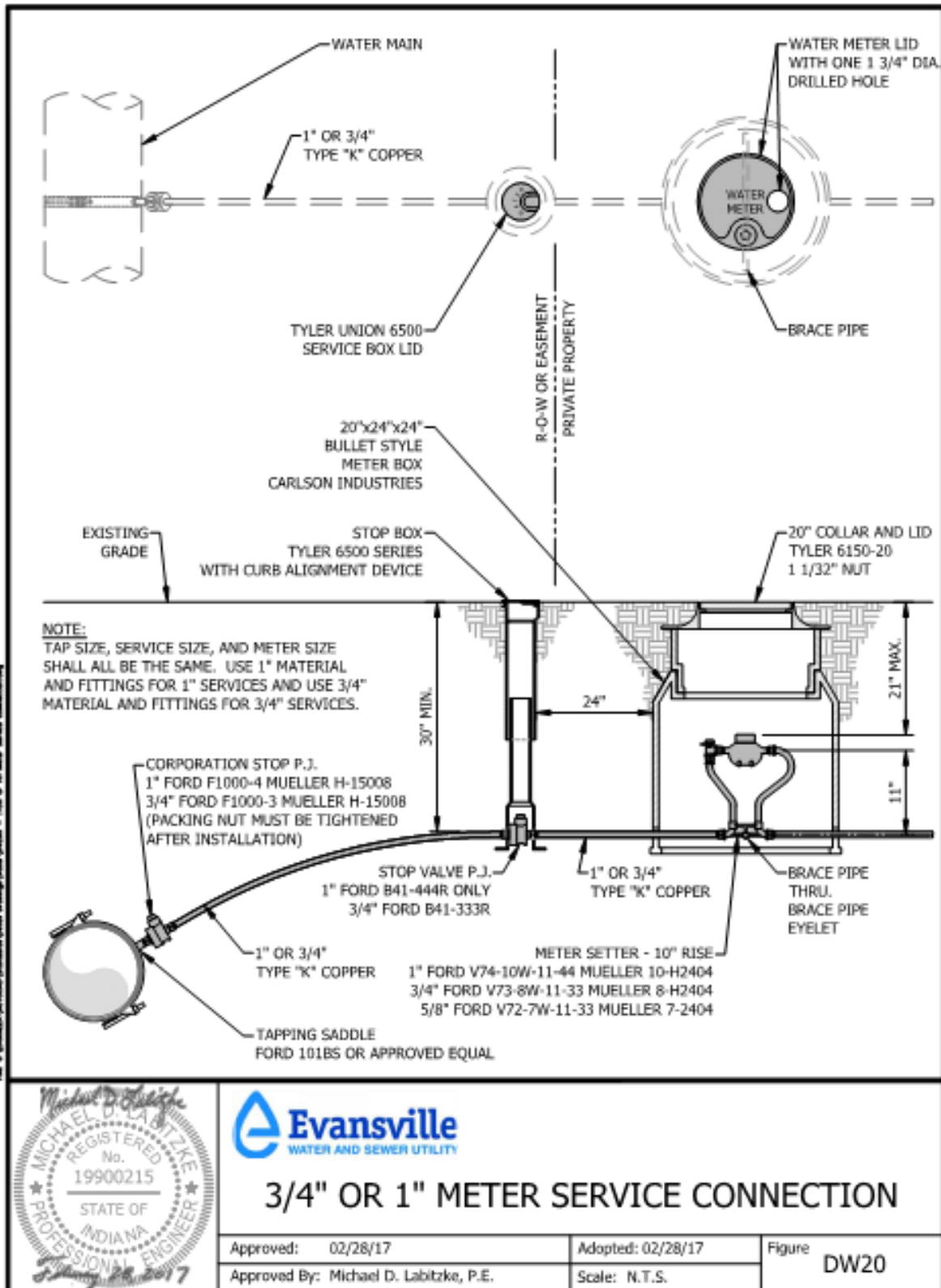

Figure 6-45: Detail DW-20 3/4" or 1" Meter Service Connection

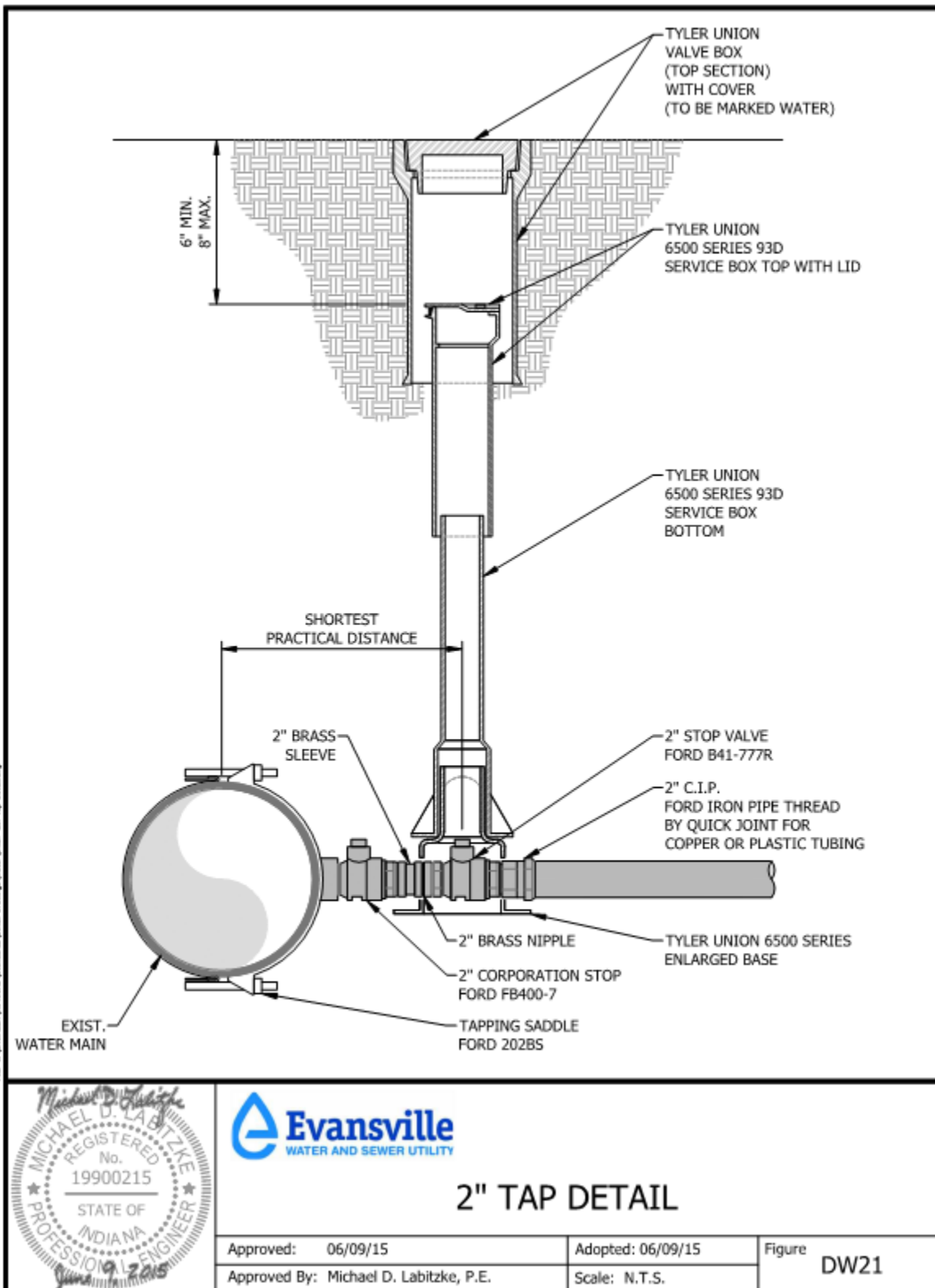

Figure 6-46: Detail DW-21 2" Tap Detail

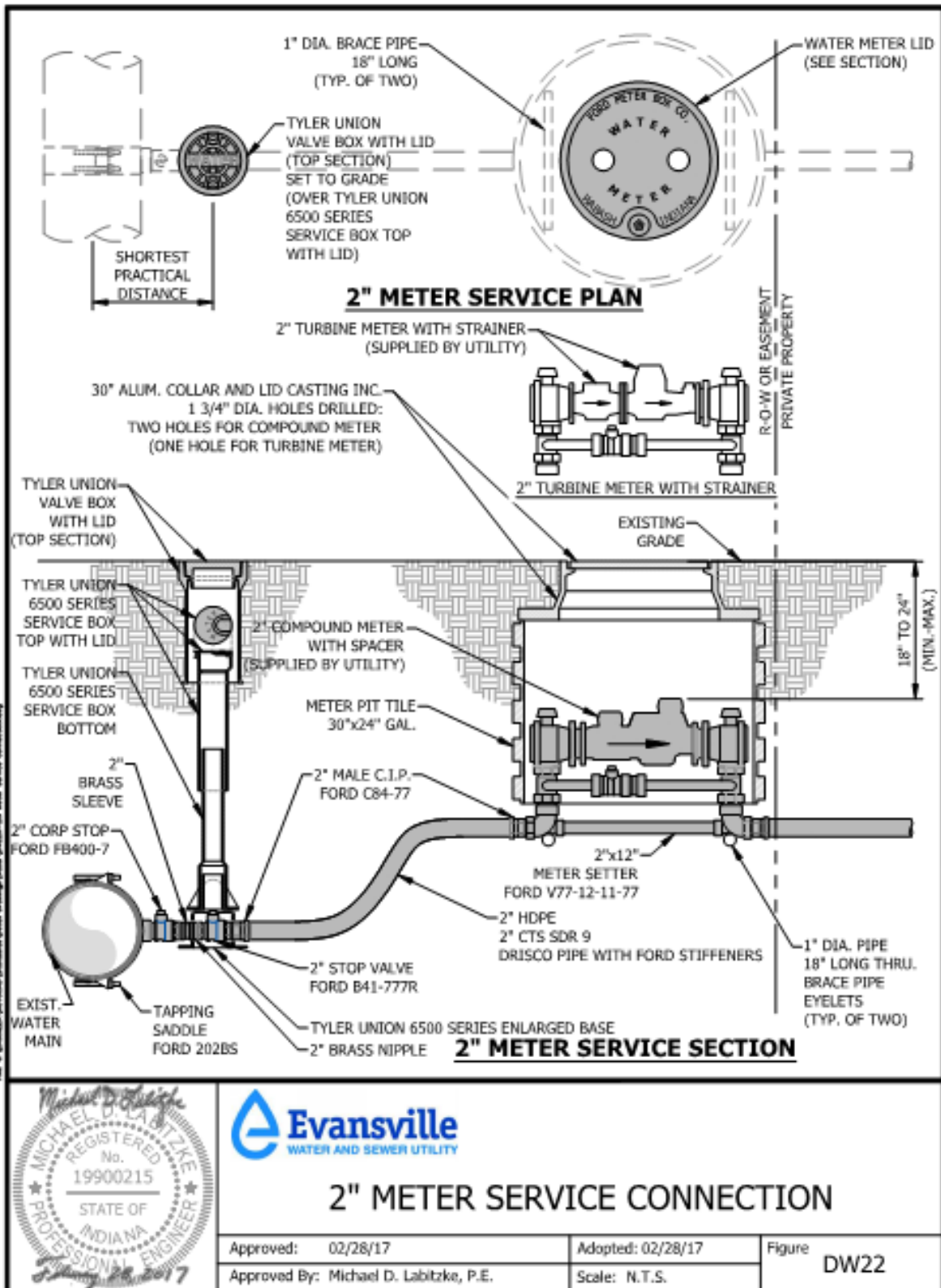
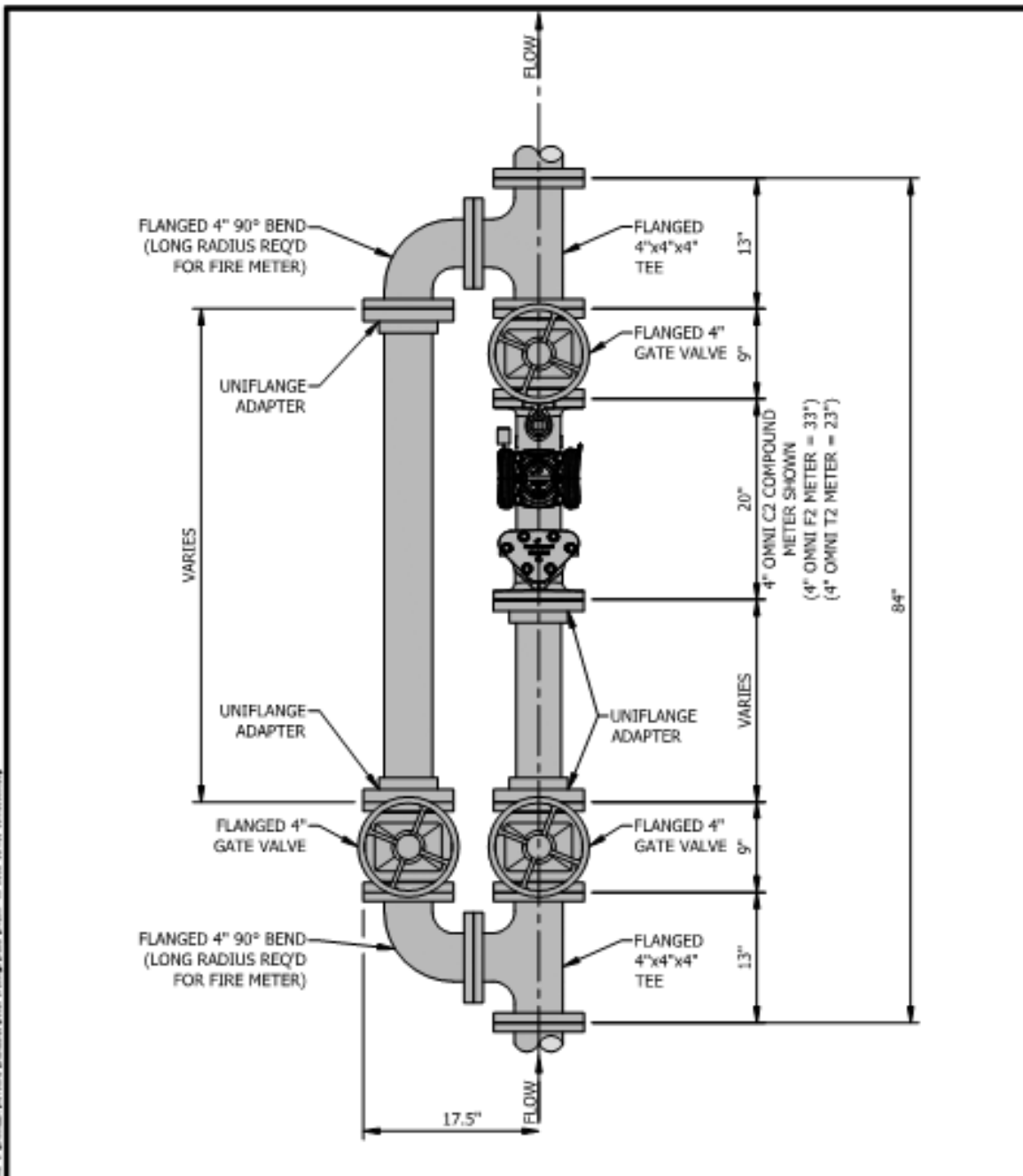
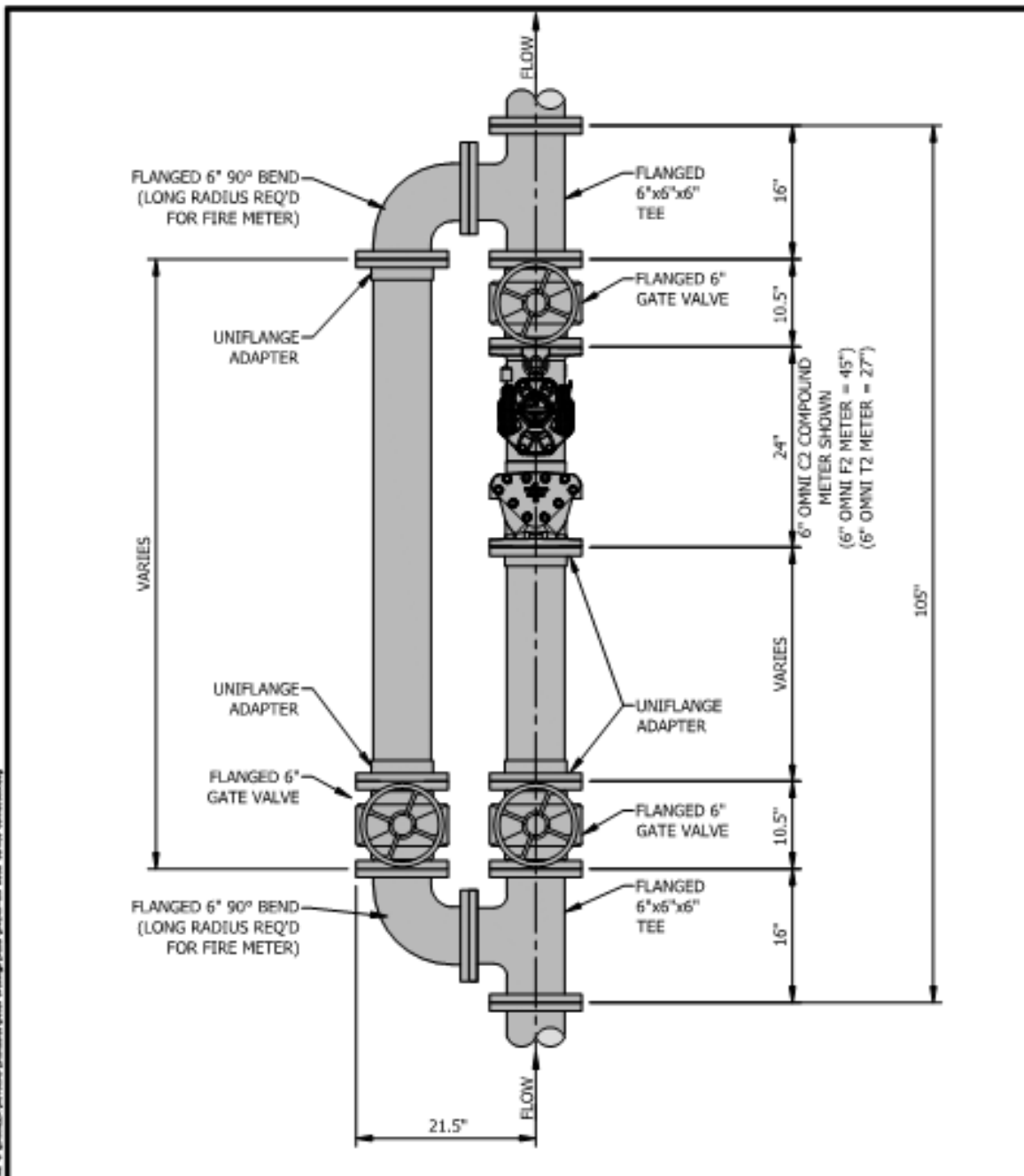

Figure 6-47: Detail DW-22 2" Meter Service Connection



			<h3>4" METER SERVICE CONNECTION</h3>	
	Approved: 02/28/17 Approved By: Michael D. Labitzke, P.E.	Adopted: 02/28/17 Scale: N.T.S.	Figure DW23	

Figure 6-48: Detail DW-23 4" Meter Service Connection



			<h3>6" METER SERVICE CONNECTION</h3>	
	Approved: 02/28/17 Approved By: Michael D. Labitzke, P.E.	Adopted: 02/28/17 Scale: N.T.S.	Figure DW24	

Figure 6-49: Detail DW-24 6" Meter Service Connection

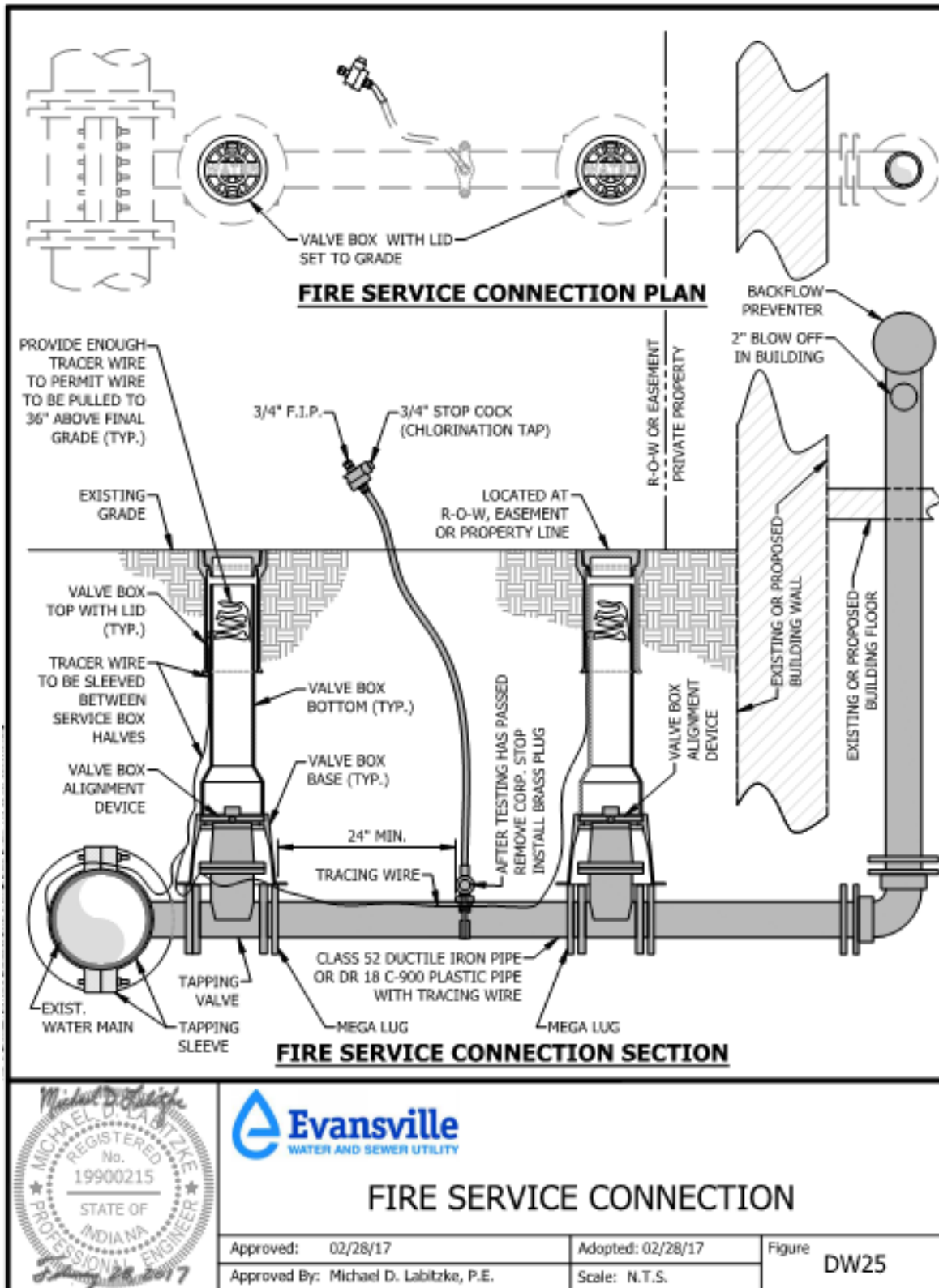

Figure 6-50: Detail DW-25 Fire Service Connection

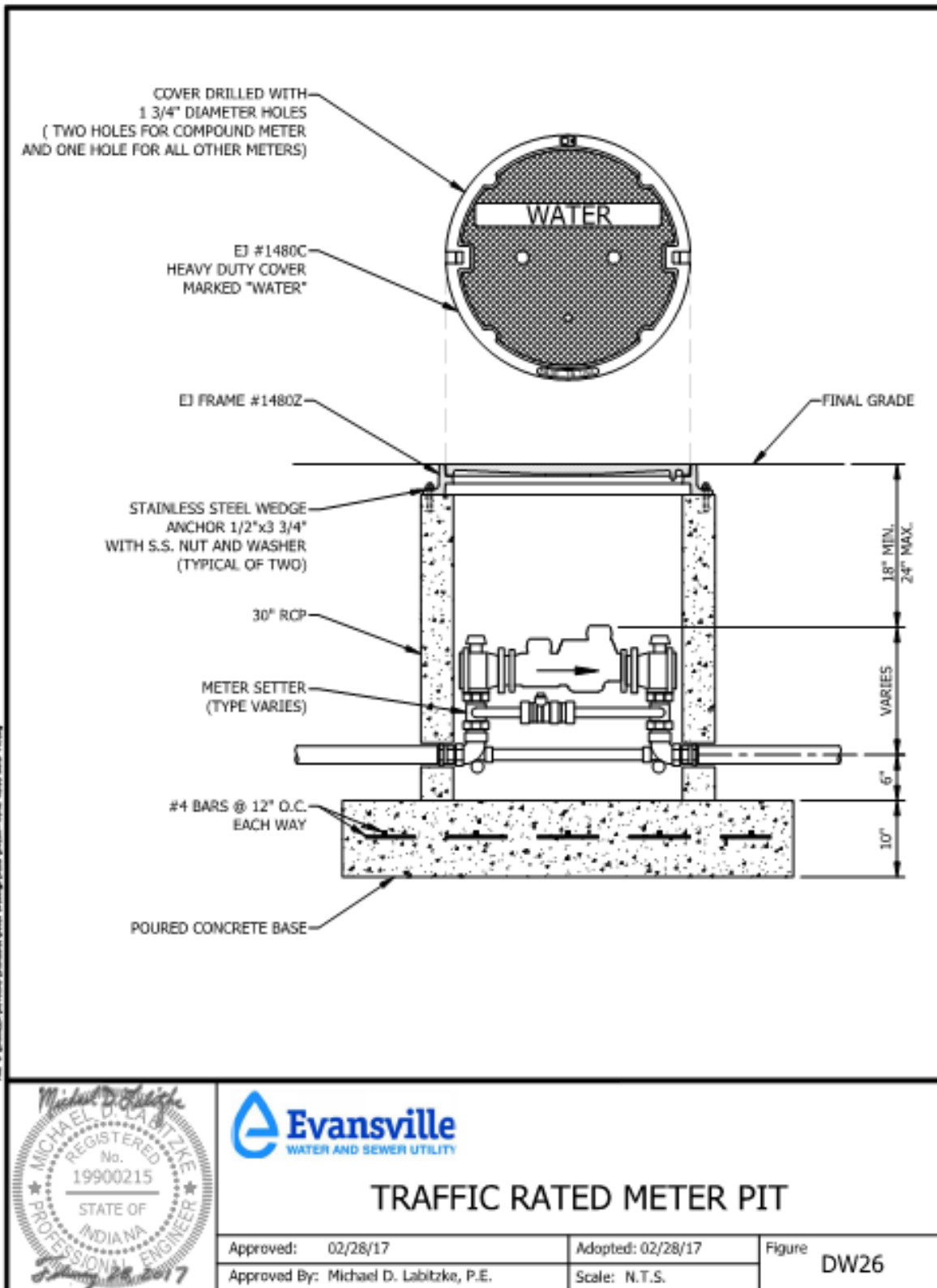

Figure 6-51: Detail DW-26 Traffic Rated Meter Pit

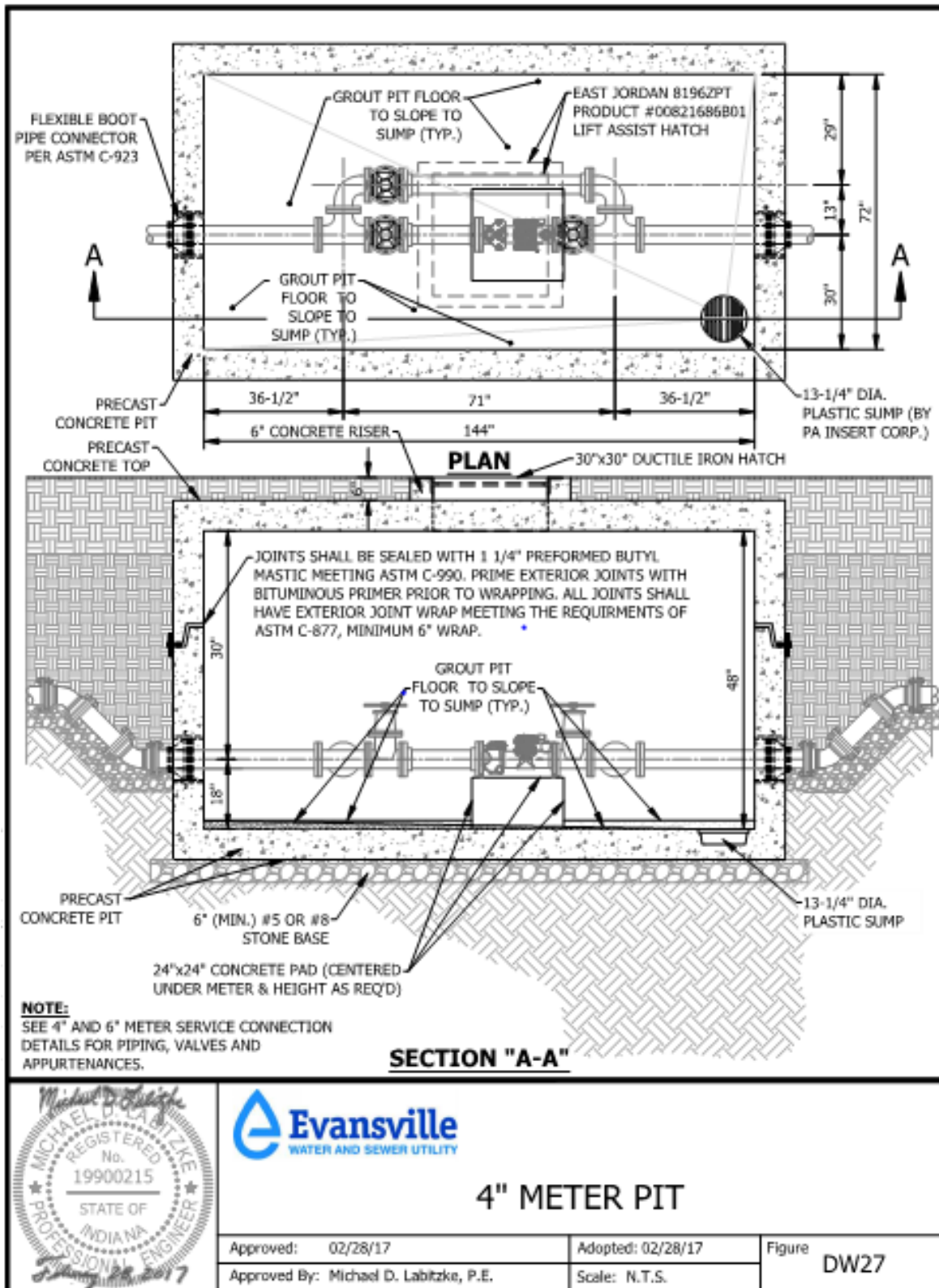

Figure 6-52: Detail DW-27 4" Meter Pit

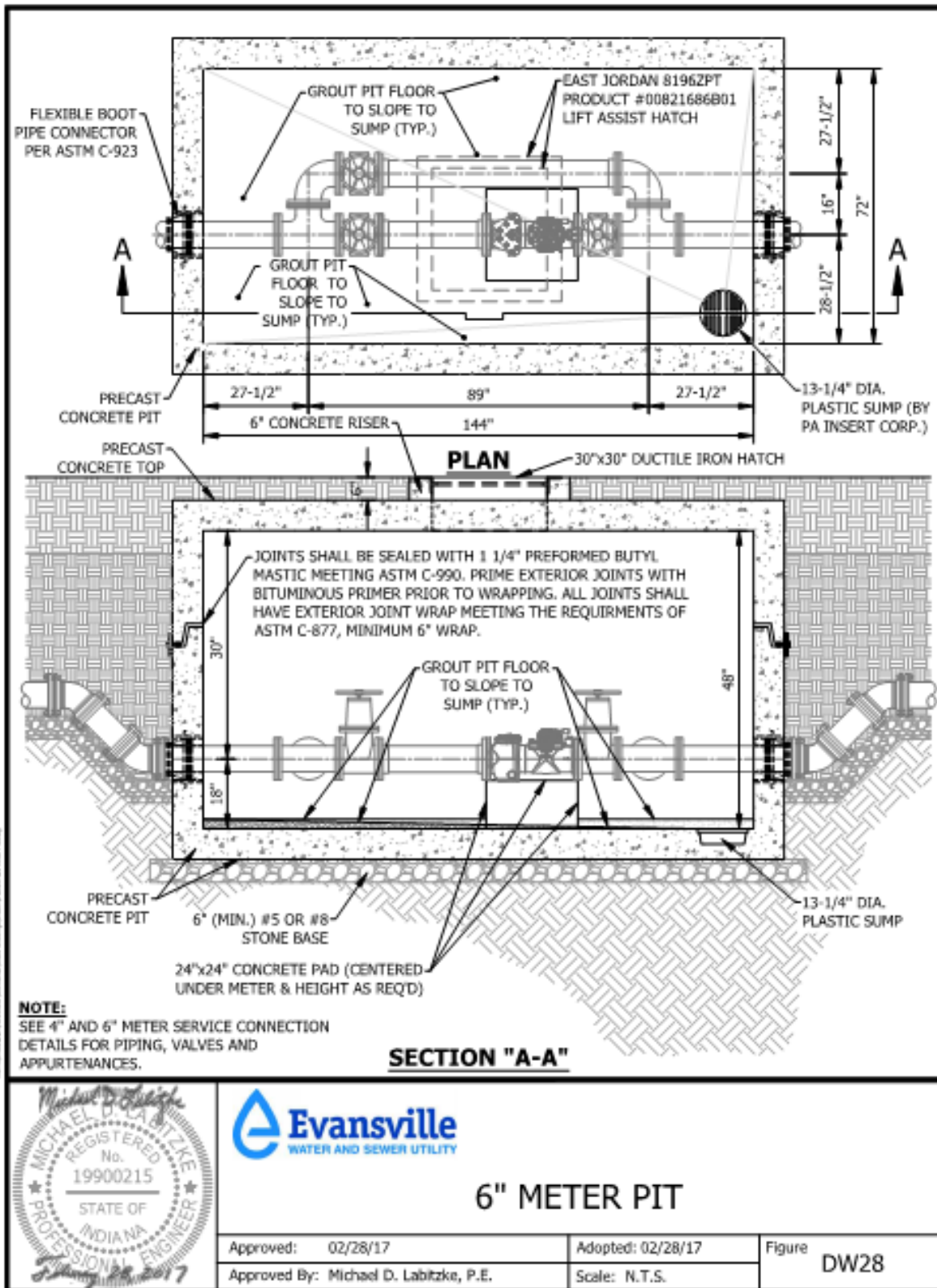
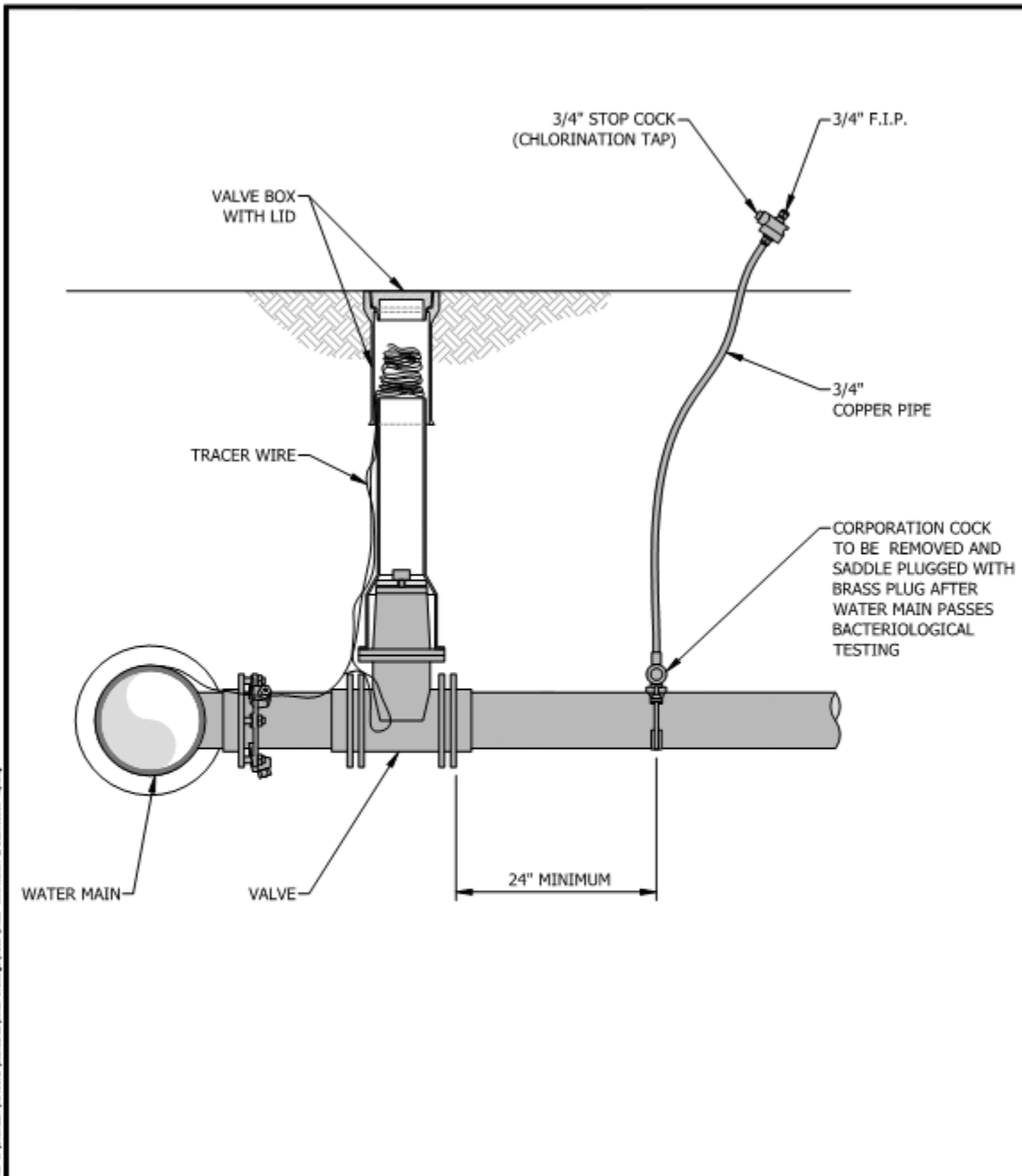

Figure 6-53: Detail DW-28 6" Meter Pit



			<p>CHLORINATION / DISINFECTION TAP</p>
	Approved: 06/09/15 Approved By: Michael D. Labitzke, P.E.	Adopted: 06/09/15 Scale: N.T.S.	

Figure 6-54: Detail DW-29 Chlorination / Disinfection Tap

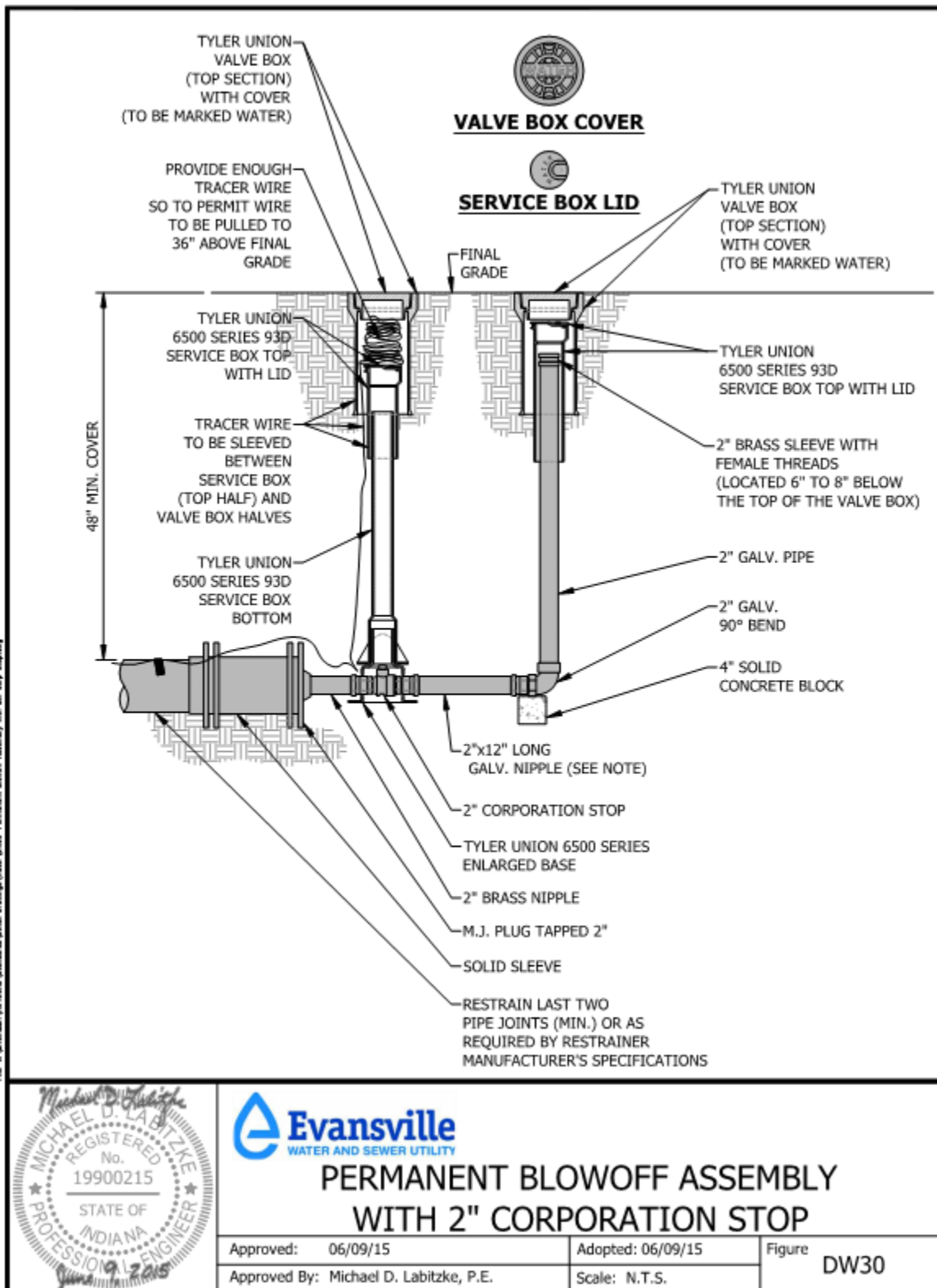

Figure 6-55: Detail DW-30 Permanent Blow-Off Assembly with 2" Corporation Stop

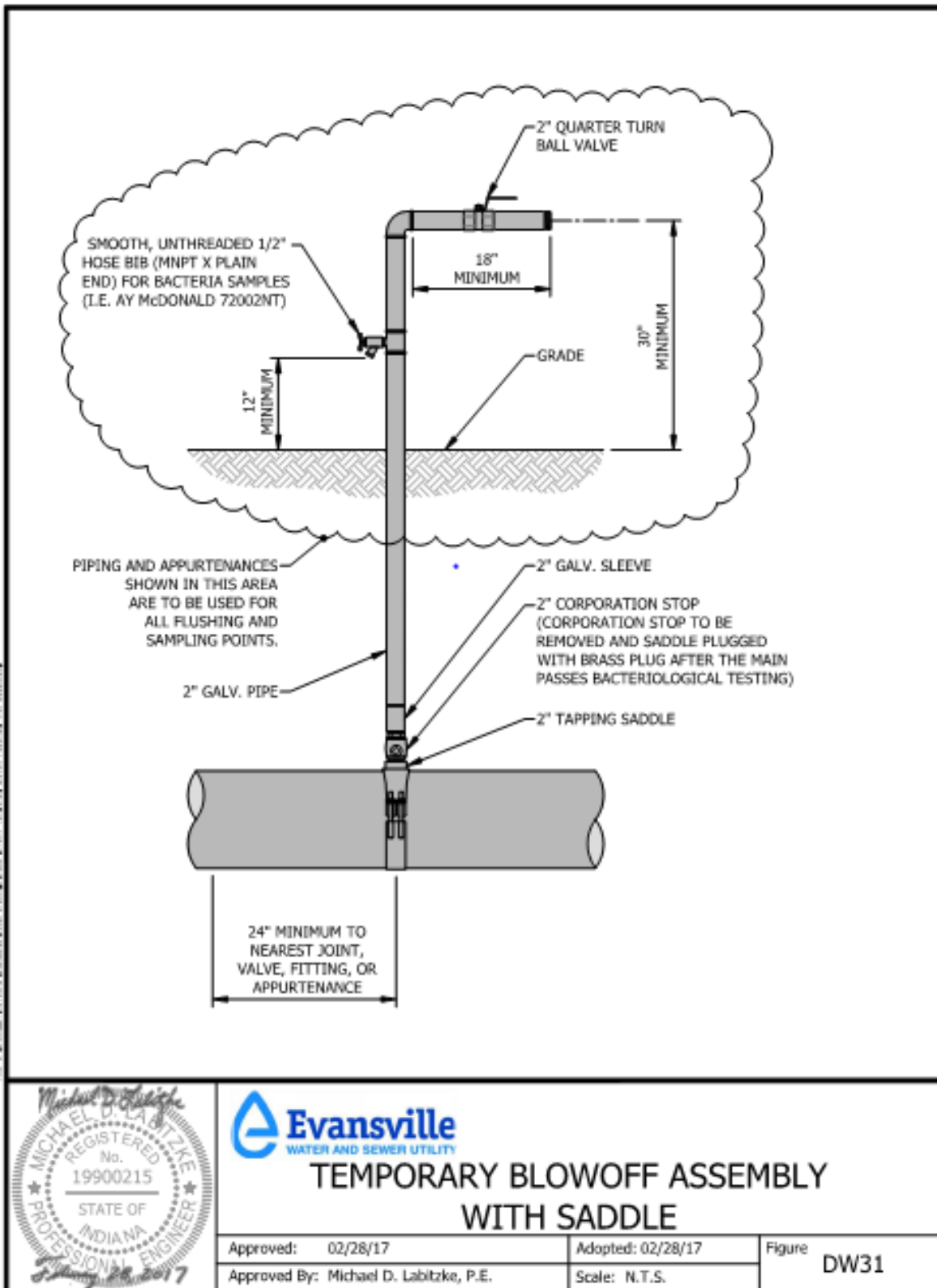

Figure 6-56: Detail DW-31 Temporary Blow-Off Assembly with Saddle

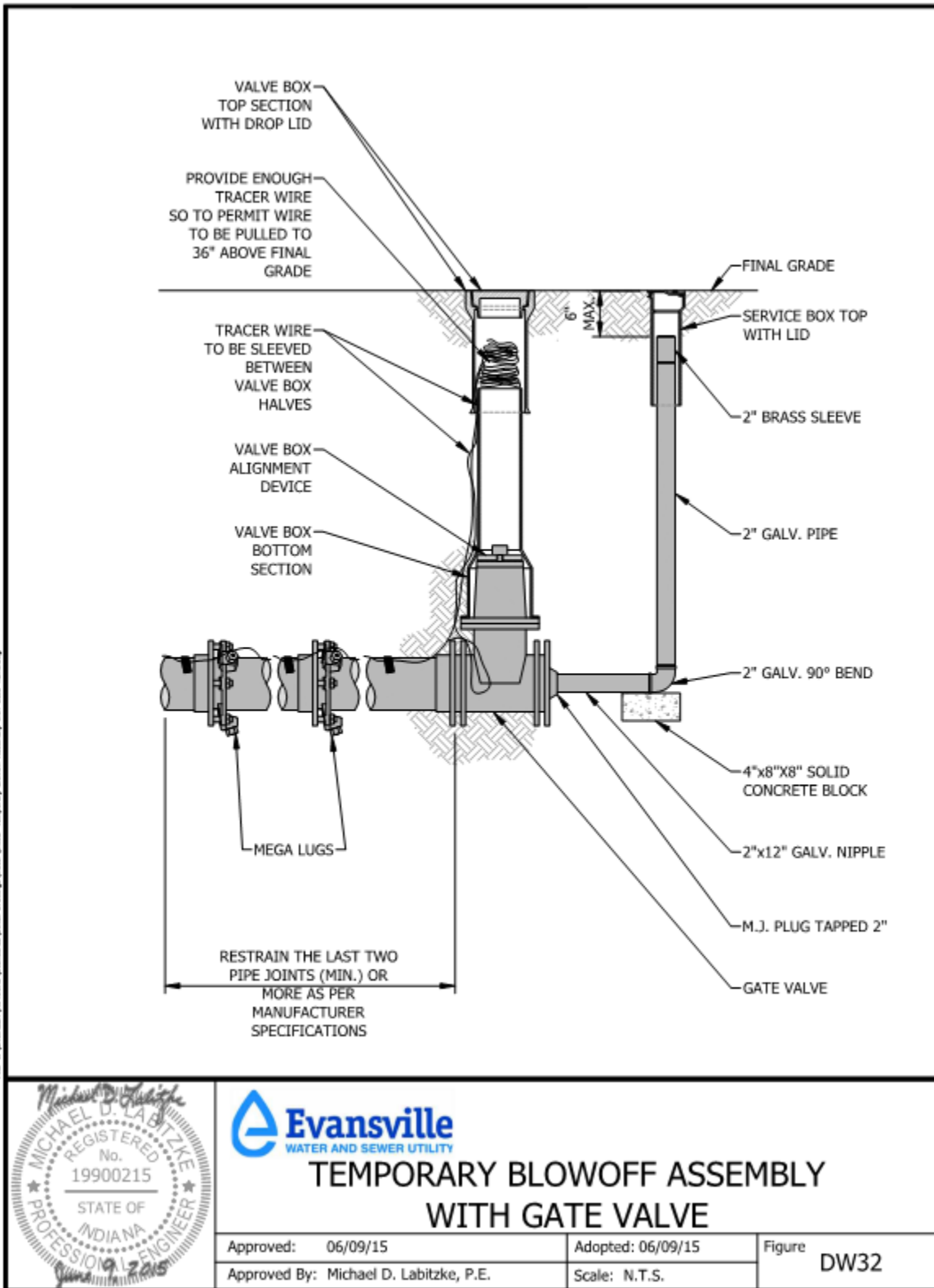

Figure 6-57: Detail DW-32 Temporary Blow-Off Assembly with Gate Valve

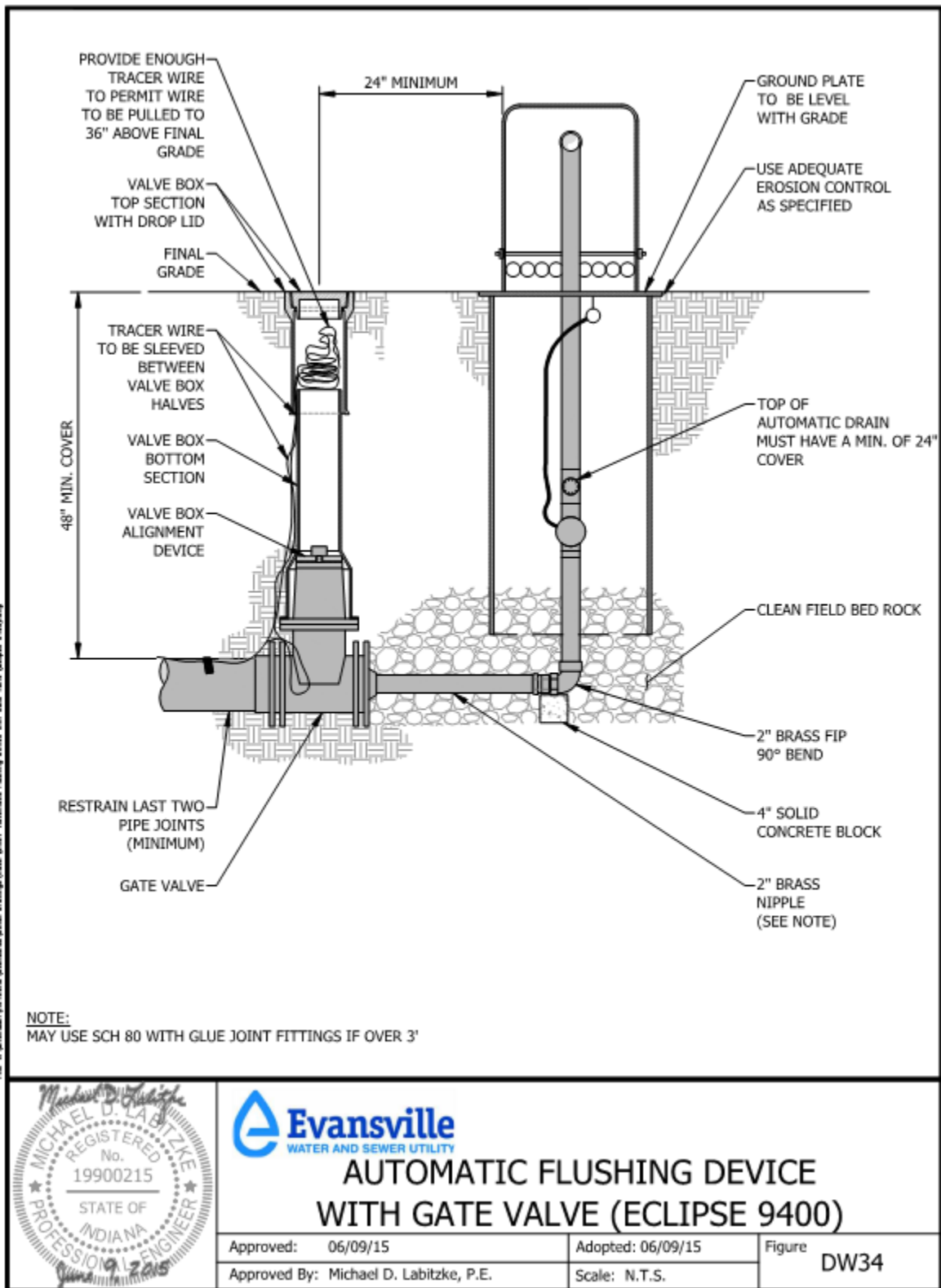

Figure 6-59: Detail DW-34 Automatic Flushing Device with Gate Valve (Eclipse 9400)

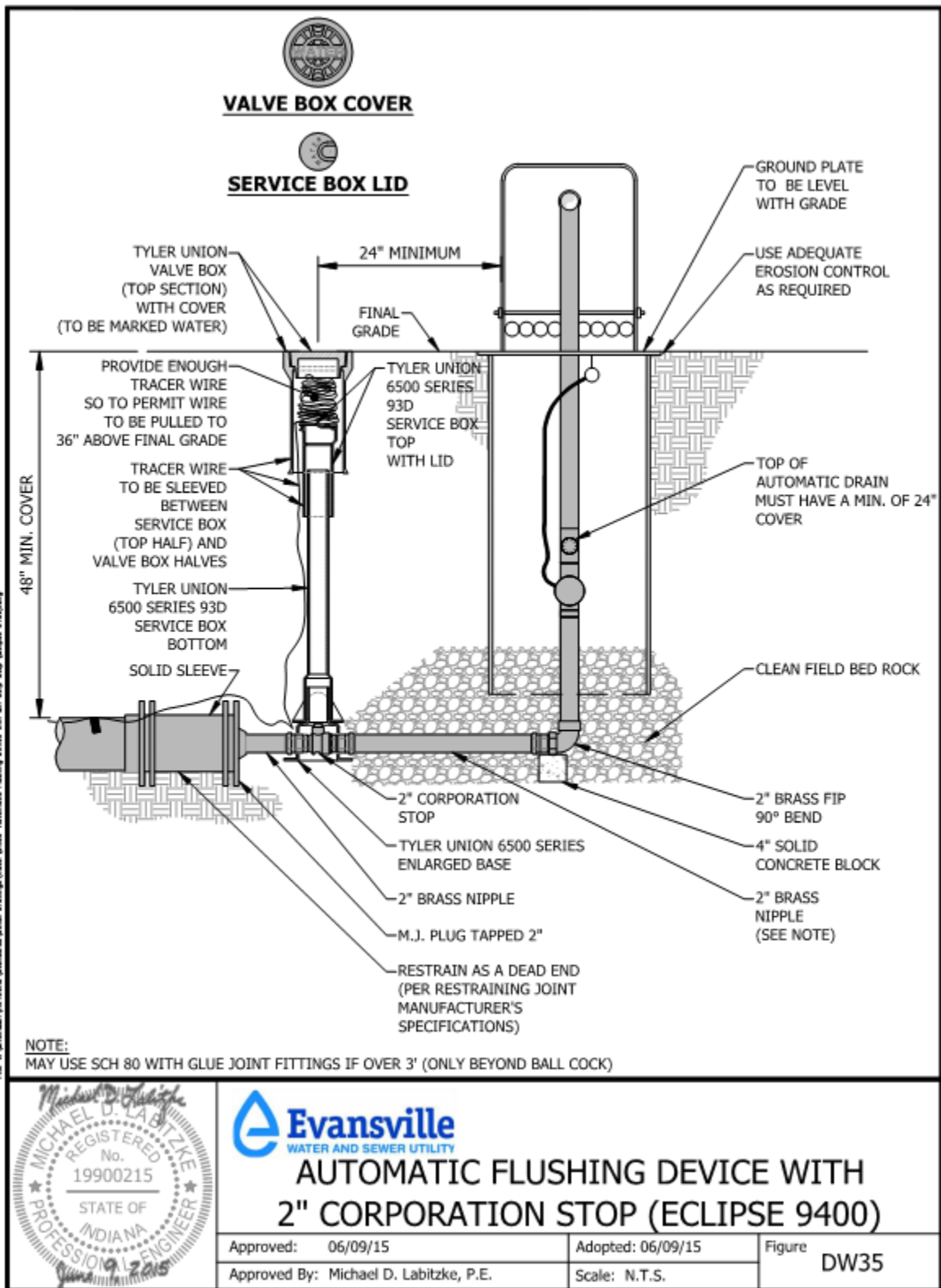

Figure 6-60: Detail DW-35 Automatic Flushing Device with 2" Corporation Stoppe (Eclipse 9400)

THESE NOTES PERTAIN TO DETAIL FIGURES DW33, DW34 AND DW35

AUTOMATIC FLUSHING DEVICE SHALL HAVE A 2" BRASS FIP INLET, LEADING VERTICALLY INTO A 2" AUTOMATIC SOLENOID VALVE.
 AUTOMATIC SOLENOID VALVE SHALL HAVE AN INTERNAL, SELF-CLEANING DEBRIS SCREEN, AND HAVE A 220 PSI RATING.
 EACH UNIT SHALL BE FURNISHED WITH A STAND-ALONE VALVE CONTROLLER.
 VALVE CONTROLLER WILL NOT REQUIRE A SECOND HAND-HELD DEVICE FOR PROGRAMING.
 CONTROLLER MUST HAVE A MINIMUM OF 9 POSSIBLE FLUSHING CYCLES PER DAY, SHALL BE SUBMERSIBLE TO 12 FEET, OPERATE WITH 9 VOLT BATTERY AND HAVE RESIN-SEALED ELECTRICAL COMPONENTS.
 SOLENOID SHALL HAVE NO LOOSE PARTS WHEN REMOVED FROM VALVE.
 EACH UNIT SHALL HAVE A DOUBLE-VALVE, ALL BRASS, SAMPLING POINT.
 REMOVAL OF 2" SOLENOID VALVE SHALL BE POSSIBLE VIA AN O-RING CONNECTOR LOCATED UNDER THE VALVE, AFTER REMOVAL OF STAINLESS STEEL ACCESS PLATE.
 VALVE ASSEMBLY SHALL BE HOUSED IN A PVC ENCLOSURE AND EACH UNIT SHALL BE SELF DRAINING, NON-FREEZING.
 ALL ABOVE-GROUND COMPONENTS SHALL BE CONTAINED WITHIN A UV-RESISTANT LOCKING COVER, AS MANUFACTURED BY KUPFERLE FOUNDRY COMPANY.
 ST. LOUIS, MO.
 1-800-231-3990
 MODEL No.9800 OR MODEL No.9400 OR APPROVED EQUAL.

PRIOR TO THE PERMANENT INSTALLATION OF THE VERTICAL PIPING FOR THE AUTOMATIC FLUSHING DEVICE, THE VERTICAL PIPING AND SURFACE COMPONENTS OF THE TEMPORARY BLOWOFF ASSEMBLY REPRESENTED IN DW31 SHALL BE INSTALLED ABOVE THE 2" BRASS FIP 90° BEND FOR A FLUSHING AND SAMPLING LOCATION DURING TESTING.



AUTOMATIC FLUSHING DEVICE NOTES

Approved: 02/28/17	Adopted: 02/28/17	Figure DW36
Approved By: Michael D. Labitzke, P.E.	Scale: N.T.S.	

Figure 6-61: Detail DW-36 Automatic Flushing Device Notes

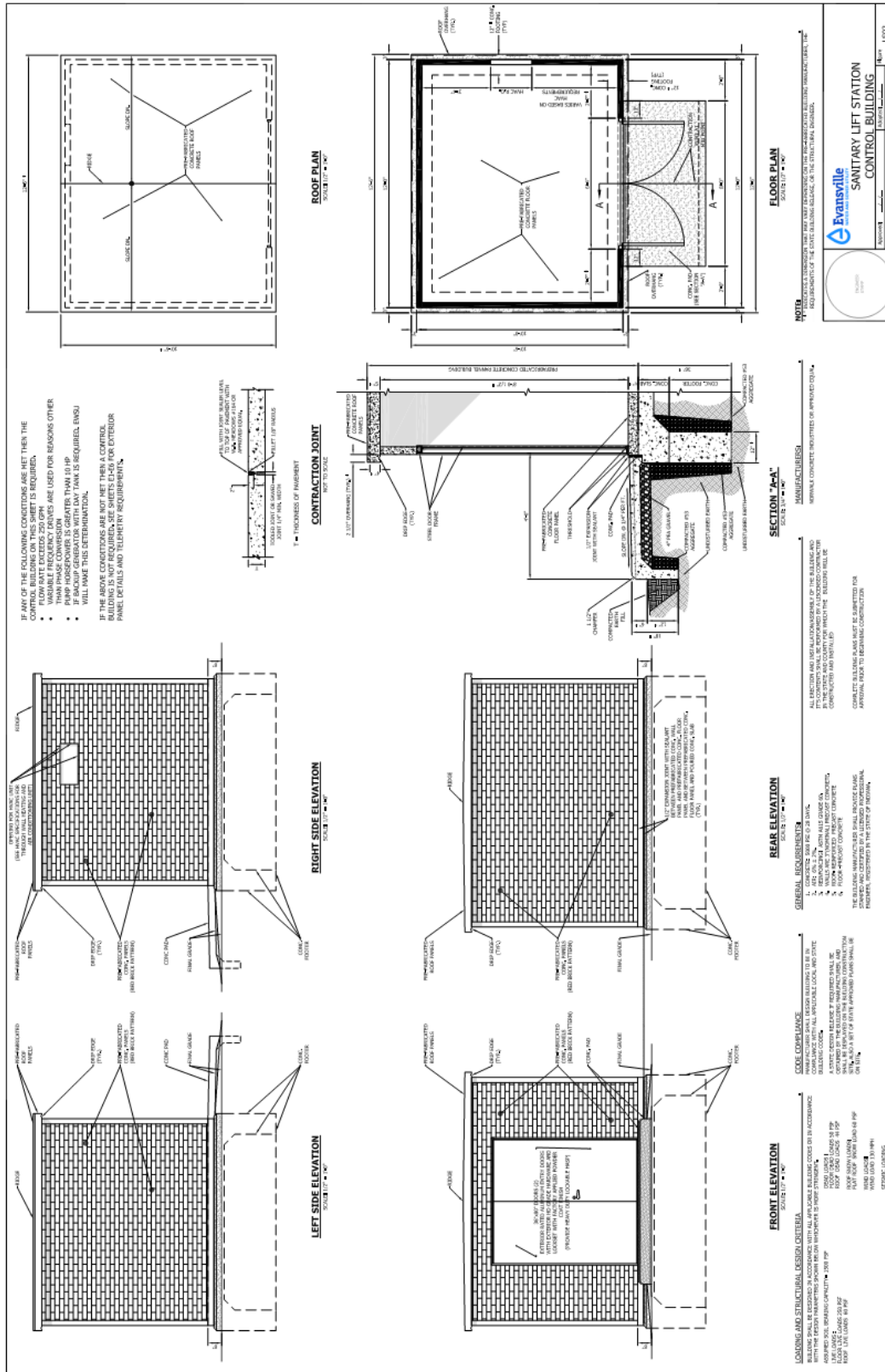

Figure 6-63: Sanitary Lift Station Control Building